

Aircraft Flight Manual

Doc. No. 2008/100

Ed. 2 – Rev. 16

14 October 2025



TECNAM P2008 JC

MANUFACTURER: *C. A. TECNAM S.p.A.*

AIRCRAFT MODEL: *P2008 JC*

EASA TYPE CERTIFICATE NR.: *A .583 (DATED 2013, 27 SEPTEMBER)*

SERIAL NUMBER:

BUILD YEAR:

REGISTRATION MARKINGS:

This Aircraft Flight Manual is approved and applies only to EASA CS-VLA certified airplanes.

This Manual must be carried in the airplane at all times.

This aeroplane has to be operated in compliance with procedures and limitations contained herein.

Costruzioni Aeronautiche **TECNAM** SpA
Via Maiorise
CAPUA (CE) – Italy
Tel. +39-0823 997538
WEB: www.tecnam.com

SECTION 0

INDEX

1.	RECORD OF REVISIONS	3
2.	LIST OF EFFECTIVE PAGES	7
3.	FOREWORD.....	9
4.	SECTIONS LIST	10

1. RECORD OF REVISIONS

Any revision to the present Manual, except actual weighing data, is recorded: a Record of Revisions is provided in this Section and the operator is advised to make sure that the record is kept up-to-date.

The Manual issue is identified by Edition and Revision codes reported on each page, lower right side.

The revision code is numerical and consists of the number “0”; subsequent revisions are identified by the change of the code from “0” to “1” for the first revision to the basic publication, “2” for the second one, etc.

Should be necessary to completely reissue a publication for contents and format changes, the Edition code will change to the next number (“2” for the second edition, “3” for the third edition etc).

Additions, deletions and revisions to existing text will be identified by a revision bar (black line) in the left-hand margin of the page, adjacent to the change.

When technical changes cause expansion or deletion of text which results in unchanged text appearing on a different page, a revision bar will be placed in the right-hand margin adjacent to the page number of all affected pages providing no other revision bar appears on the page.

These pages will be updated to the current regular revision date.

NOTE

It is the responsibility of the owner to maintain this handbook in a current status when it is being used for operational purposes.

Rev No	Revised page	Description of Revision	Tecnam Approval			EASA Approval or Under DOA Privileges
			DO	OoA	HDO	
0	all	Editorial revision.	A. Sabino	C. Caruso	M. Oliva	Approved under the authority of DOA, ref. EASA.21J.335 (MOD2008/097.180126)
1	0-1,4,7	Cover, RoR and LOEP updated.	A. Sabino	C. Caruso	M. Oliva	.Approved under the authority of DOA, ref. EASA.21J.335 (MOD2008/103.180312)
	2-6	Airspeed indicator markings amended; the indication is now proper for both analogue and digital instruments.				
	3-20	Note amended.				
	4-3, 4-4	Note amended; information have been added to airspeed for normal operations table; paragraph shifted from page 3 to page 4.				
	4-9, 4-12 thru 17	Checklists amended; note to PFI revised; speed information have been moved to page 4-3.				
	6-9	W&B calculation sample.				
	6-11 thru 13	Equipment list.				
	7-1,5 thru 16	Contents rearranged.				
9-3	Supplements list updated.					
2	0-1,4,7	Cover, RoR and LOEP updated.	G.Valentino	D.Ronca	M. Oliva	Approved under the authority of DOA, ref. EASA.21J.335 (MOD2008/111.180802)
	4-12	Added check of pitot heating system (if installed)				
	6-11 thru 13	Equipment list.				
	9-3	Supplements list updated: added Supplement S14				
3	0-1,4,7	Cover, RoR and LOEP updated.	A. Sabino	D. Ronca	M. Oliva	Approved under the authority of DOA, ref. EASA.21J.335 (MOD2008/113.190404)
	6-12	Equipment list amended				
	9-3	Supplements list updated				
4	0-1,4,7	Cover, RoR and LOEP updated.	A. Sabino	D. Ronca	M. Oliva	Approved under the authority of DOA, ref. EASA.21J.335 (MOD2008/123.190620)
	6-13	Amended equipment list				
	9-3	Supplements list updated				
5	0-1,4,7	Cover, RoR and LOEP updated.	A. Sabino	D. Ronca	M. Oliva	Approved under the authority of DOA, ref. EASA.21J.335 (MOD2008/126.190711)
	6-13	Amended equipment list				
	7-17,18	New brake pumps				
	9-3	Supplements list updated				

Rev No	Revised page	Description of Revision	Tecnam Approval			EASA Approval or Under DOA Privileges
			DO	OoA	HDO	
6	0-1,5,7	Cover, RoR and LOEP updated.	G. Valentino	D. Ronca	M. Oliva	Approved under the authority of DOA, ref. EASA.21J.335 (MOD2008/136.200219)
	4-13 thru 15	Editorial revision.				
	6-13	Update to include alternative P/N for GSU equipment (MOD2008/130).				
7	0-1, 5, 7	Cover, RoR and LOEP updated.	G. Valentino	D. Ronca	M. Oliva	Approved under the authority of DOA, ref. EASA.21J.335 (MOD2008/143.200730)
	2-5	Explanation V_{FE} definition				
	2-25	Choke placard update				
	6-11	Included alternative P/N for landing light				
	6-12	Included alternative P/N for ELT (MOD2008/015)				
	7-13	Included alternative P/N for GTX (MOD2008/140)				
9-3	Supplements list updated					
8	0-1, 5, 7	Cover, RoR and LOEP updated.	G. Valentino	D. Ronca	M. Oliva	Approved under the authority of DOA, ref. EASA.21J.335 (MOD2008/144.201022)
	9-3	Supplements list updated				
9	0-1, 5, 7	Cover, RoR and LoEP updated.	L. De Salvi	D. Ronca	M. Oliva	Approved under the authority of DOA, ref. EASA.21J.335 (MOD2008/162.210701)
	3-1, 8, 15	Parking Brake Wording unified				
	4-12,13,14,15,16,17	Parking Brake Wording unified				
	6-11,12, 13	Typo and equipment list Update				
	7-1	Typo error				
	8-1, 7	Towing Procedure Optimization				
9-3	Supplements list updated					
10	0-1, 5, 7	Cover, RoR and LoEP updated.	L. De Salvi	D. Ronca	M. Oliva	Approved under the authority of DOA, ref. EASA.21J.335 (MOD2008/188.230126)
	2-10	Limitations clarification				
	4-4, 16	Typo error correction and procedure optimization				
	6-8, 11, 12, 13	Typo error, MOD2008/185, MOD2006/179				
	9-3	Supplements list updated				

Rev No	Revised page	Description of Revision	Tecnam Approval			EASA Approval or Under DOA Privileges
			DO	OoA	HDO	
11	0-1,6,7	Cover, RoR and LOEP updated.	G. Valentino	D. Ronca	M. Oliva	Approved under the authority of DOA, ref. EASA.21J.335 (MOD2008/199.230605)
	4-14 6-11, 13	Applicability clarification MOD2008/193 MOD2008/182 Normal Procedures Optimization				
	9-3	Supplements list updated.				
12	0-1, 6, 7 6-11, 12, 13 7-13 9-3	Cover, RoR and LoEP updates MOD2008/200 MOD2008/194 MOD2008/204 MOD2008/129 MOD2008/043 Typo error S-09	F. Paloni	D. Ronca	M. Oliva	Approved under the authority of DOA, ref. EASA.21J.335 (MOD2008/205.231020)
13	0-1, 6, 7 9-3	Cover, RoR and LoEP updates MOD2008/210 (EASA Approval 10084361) Typo corrections Suppl. S10	F. Paloni	D. Ronca	M. Oliva	Approved under the authority of DOA, ref. EASA.21J.335 (MOD2008/216.240508)
14	0-1, 6, 7 2-8, 23 4-14 6-12, 13 9-3	Cover, RoR and LoEP updates Typo error in S-06, S-07, S-14 MOD2008/230 MOD2008/236 MOD2008/239	G. Valentino	D. Ronca	M. Oliva	Approved under the authority of DOA, ref. EASA.21J.335 (MOD2008/237.250715)
15	0-1, 6, 7 6-12, 13 9-3 Suppl.S12 refer to suppl RoR	Cover, RoR and LoEP updates Typo errors MOD2008/238 Refer to RoR of Suppl.S12	F. Losappio	D. Ronca	M. Oliva	Approved under the authority of DOA, ref. EASA.21J.335 (MOD2008/251.250805)
16	0-1, 6, 7 2-27 9-3 Suppl.S01 refer to suppl RoR	Cover, RoR and LoEP updates Optimizations Refer to RoR of Suppl.S01	F. Losappio	D. Ronca	M. Oliva	Approved under the authority of DOA, ref. EASA.21J.335 (MOD2008/254.251014)

2. LIST OF EFFECTIVE PAGES

The List of Effective Pages (LOEP), applicable to manuals of every operator, lists all the basic AFM pages: each manual could contain either basic pages or one variant of these pages when the pages of some Supplements are embodied.

Pages affected by the current revision are indicated by an asterisk (*) following the revision code.

Edition 1

30 July 2013

Edition 2

15 January 2018

Section	Pages	Revision
Section 0	2, 3, 8,9, 10	Rev 0
	4	Rev 5
	5	Rev 10
	1, 6, 7	Rev 16
Section 1	1 thru 14	Rev 0
Section 2	1 thru 4, 7, 9 thru 22, 26, 28 thru 30	Rev 0
	6	Rev 1
	5, 24, 25	Rev 7
	10	Rev 10
	8, 23	Rev 14
	27	Rev 16
Section 3	2 thru 7, 9 thru 14, 16 thru 19, 21, 22	Rev 0
	20	Rev 1
	1, 8, 15	Rev 9
Section 4	1, 2, 10, 11, 18	Rev 0
	3 thru 9	Rev 1
	12, 13, 15 thru 17	Rev 9
	4, 16	Rev 10
	14	Rev. 14
Section 5	1 thru 16	Rev 0
Section 6	1 thru 7, 10, 14	Rev 0
	9	Rev 1
	8,	Rev 10
	11	Rev 12
	12, 13	Rev 15
Section 7	2 thru 4	Rev 0
	5 thru 12, 14 thru 16	Rev 1
	17, 18	Rev 5
	13	Rev 7
	1	Rev 9
	13	Rev 12
Section 8	2 thru 6, 8 thru 10	Rev 0
	1, 7	Rev 9
Section 9	1, 2 and 4	Rev 0
	3	Rev 16

INTENTIONALLY LEFT BLANK

3. FOREWORD

Tecnam *P2008 JC* is a single-engine two-seat aircraft with a strut braced high wing and fixed landing gear.

Section 1 provides general information and it contains definitions, symbols explanations, acronyms and terminology used.

Before using the airplane, you are recommended to read carefully this manual: a deep knowledge of airplane features and limitations will allow you for operating the airplane safely.

For further information, please contact:

*COSTRUZIONI AERONAUTICHE **TECNAM**s.r.l.*

Via MAIORISE

CAPUA (CE) - ITALY

 +39 (0)823 997538

 airworthiness@tecnam.com

4. SECTIONS LIST

General (*)	Section 1
Limitations (**)	Section 2
Emergency Procedures (**)	Section 3
Normal Procedures (**)	Section 4
Performance (***)	Section 5
Weight and balance (*)	Section 6
Airframe and Systems description (*)	Section 7
Ground Handling and Service (*)	Section 8
AFM Supplements list (*)	Section 9

(*) non-approved Section

(**) approved Section

(***) approved Section except for pages 5-1 thru 5-4, 5-6, 5-11 thru 5-13

SECTION 1 - GENERAL

INDEX

1. INTRODUCTION	3
2. CERTIFICATION BASIS	3
3. WARNINGS – CAUTIONS – NOTES	3
4. THREE-VIEW AND DIMENSIONS	4
5. ENGINE	6
6. PROPELLER	6
7. FLIGHT CONTROL SURFACES TRAVEL	7
8. SPECIFIC LOADINGS	7
9. ACRONYMS AND TERMINOLOGY	8
10. UNIT CONVERSION CHART	13
11. LITRES / US GALLONS CONVERSION CHART	14

INTENTIONALLY LEFT BLANK

1. INTRODUCTION

The Flight Manual has been prepared to provide pilots and instructors with information for the safe and efficient operation of this very light airplane.

This manual includes the material required to be furnished to the pilot of CS-VLA. It also contains supplemental data supplied by the airplane manufacturer.

2. CERTIFICATION BASIS

This type of aircraft has been approved by the European Aviation Safety Agency in accordance with CS-VLA including Amendment 1 and the Type Certificate No.EASA.A.583 has been issued on (date) 27th September 2013.

Category of Airworthiness: Normal

Noise Certification Basis: EASA CS 36 Amendment 2.

3. WARNINGS – CAUTIONS – NOTES

Following definitions apply to warnings, cautions and notes used in the Aircraft Flight Manual.



WARNING

means that the non-observation of the corresponding procedure leads to an immediate or important degradation of the flight safety.



CAUTION

means that the non-observation of the corresponding procedure leads to a minor or to a more or less long term degradation of the flight safety.

NOTE

draws the attention to any special item not directly related to safety but which is important or unusual.

4. THREE-VIEW AND DIMENSIONS

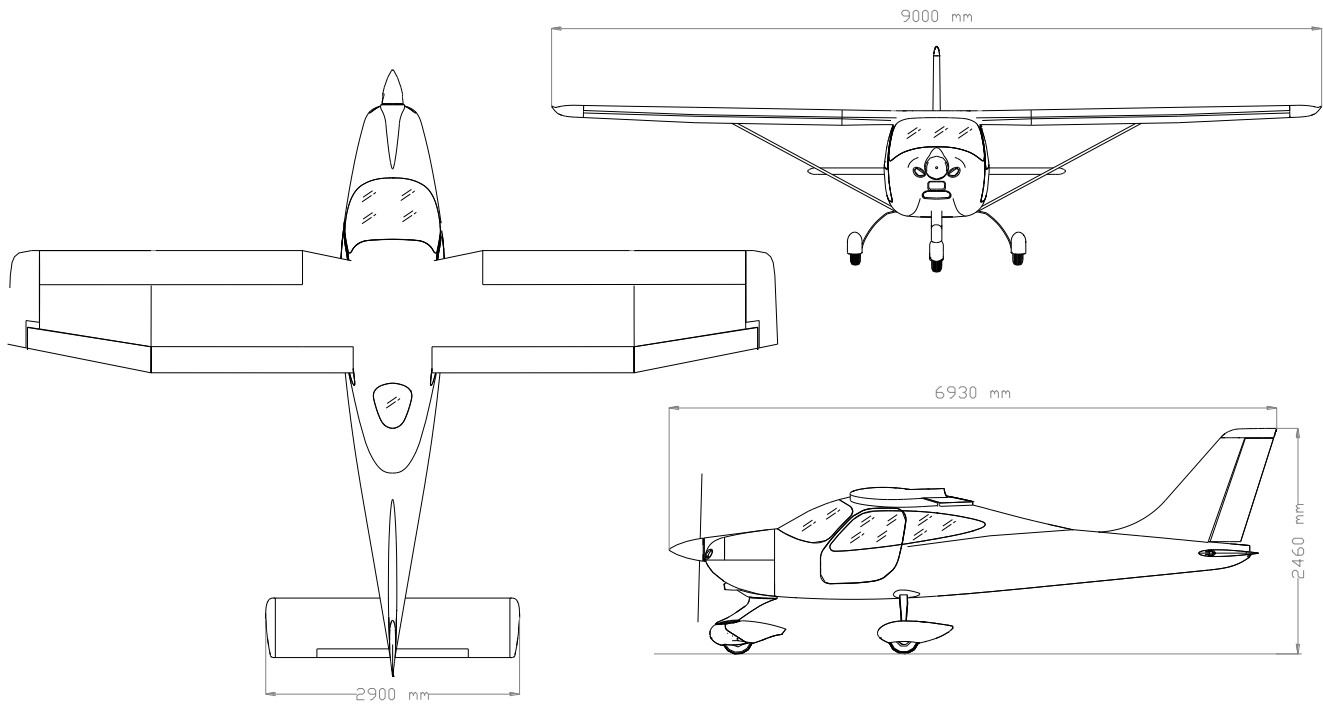

Figure 1 – General views

Dimensions***Wing***

Wing Span	9.00 m (29.5 ft)
Wing Area	12.16 m ² (130.9 ft ²)
Aspect Ratio	6.7
Taper Ratio	0.8
Wing chord	1.373 m (4.5 ft)

Fuselage

Overall length	6.93 m (22.9 ft)
Overall width	1.20 m (3.9 ft)
Overall height	2.67 m (8.8 ft)

Empennage

Stabilator span	2.90 m (9.51 ft)
Stabilator area	2.03 m ² (21.8 ft ²)
Vertical tail area	1.06 m ² (11.4 ft ²)

Landing Gear

Wheel track	1.8 m (5.9 ft)
Wheel base	1.94 m (6.4 ft)
Main gear tire	5.00-5
Nose Gear tire	5.00-5

5. ENGINE

Manufacturer	Bombardier-Rotax GmbH
Model	912 S2
Engine type	4 cylinders horizontally opposed with 1352 c.c. of overall displacement, liquid cooled cylinder heads, ram-air cooled cylinders, two carburetors, integrated reduction gear box with torsional shock absorber and overload clutch.
Maximum power (at declared rpm)	73.5 kW (98.6hp) @ 5800 rpm –5 minutes maximum. 69.0 kW (92.5hp) @ 5500 rpm (continuous)

6. PROPELLER

Manufacturer	GT Propeller
Model	GT-2/173/VRR-FW101 SRTC
Blades	One-piece 2-blade fixed pitch, constructed of wood materials, protective layer of laminate.
Diameter	1730 mm (no reduction allowed)
Type	Fixed pitch

7. FLIGHT CONTROL SURFACES TRAVEL

Ailerons	Up 22° Down 14 ° (± 2°)
Stabilator (refer to Trailing Edge)	Up 4° Down 15° (± 2°)
Stabilator trim tab (refer to Trailing Edge)	Up 2°; Down 12° (± 1°)
Rudder	RH 25° LH 25° (± 2°)
Flaps	0°; 35° (± 1°)

8. SPECIFIC LOADINGS

	MTOW 630 kg (1388lb)
Wing Loading	51 kg/m ² (10.6 lb/sqft)
Power Loading	6.29 kg/hp (14.09 lb/hp)

9. ACRONYMS AND TERMINOLOGY

KCAS	<u>Calibrated Airspeed</u> is the indicated airspeed expressed in knots, corrected taking into account the errors related to the instrument itself and its installation.
KIAS	<u>Indicated Airspeed</u> is the speed shown on the airspeed indicator and it is expressed in knots.
KTAS	<u>True Airspeed</u> is the KCAS airspeed corrected taking into account altitude and temperature.
V _A	<u>Design Manoeuvring speed</u> is the speed above the which it is not allowed to make full or abrupt control movement.
V _{FE}	<u>Maximum Flap Extended speed</u> is the highest speed permissible with flaps extended.
V _{NO}	<u>Maximum Structural Cruising Speed</u> is the speed that should not be exceeded, except in smooth air and only with caution.
V _{NE}	<u>Never Exceed Speed</u> is the speed limit that may not be exceeded at any time.
V _O	<u>Operating Manoeuvring speed</u> is the speed above the which it is not allowed to make full or abrupt control movement
V _S	<u>Stall Speed.</u>
V _{S0}	<u>Stall Speed in landing configuration</u> (flaps extended).
V _{S1}	<u>Stall speed in the given flap configuration.</u>
V _X	<u>Best Angle-of-Climb Speed</u> is the speed which allows best ramp climb performances.
V _Y	<u>Best Rate-of-Climb Speed</u> is the speed which allows the best gain in altitude over a given time.
V _R	<u>Rotation speed:</u> is the speed at which the aircraft rotates about the pitch axis during takeoff

Meteorological terminology

ISA	<u>International Standard Atmosphere</u> : is the air atmospheric standard condition at sea level, at 15°C (59°F) and at 1013.25hPa (29.92inHg).
QFE	<u>Official atmospheric pressure at airport level</u> : it indicates the aircraft absolute altitude with respect to the official airport level.
QNH	<u>Theoretical atmospheric pressure at sea level</u> : is the atmospheric pressure reported at the medium sea level, through the standard air pressure-altitude relationship, starting from the airport QFE.
OAT	<u>Outside Air Temperature</u> is the air static temperature expressed in degrees Celsius (°C).
T _s	<u>Standard Temperature</u> is 15°C at sea level pressure altitude and decreased by 2°C for each 1000 ft of altitude.
H _P	<u>Pressure Altitude</u> is the altitude read from an altimeter when the barometric subscale has been set to 1013 mb.

Aircraft performance and flight planning terminology

<i>Crosswind Velocity</i>	is the velocity of the crosswind component for the which adequate control of the airplane during takeoff and landing is assured.
<i>Usable fuel</i>	is the fuel available for flight planning.
<i>Unusable fuel</i>	is the quantity of fuel that cannot be safely used in flight.
<i>G</i>	is the acceleration of gravity.
<i>TOR</i>	is the takeoff distance measured from actual start to wheel liftoff point.
<i>TOD</i>	is total takeoff distance measured from start to 15m obstacle clearing.
<i>GR</i>	is the distance measured during landing from actual touchdown to stop point.
<i>LD</i>	is the distance measured during landing, from 15m obstacle clearing to actual stop.
<i>S/R</i>	is the specific range, that is the distance (in nautical miles) which can be expected at a specific power setting and/or flight configuration per kilogram of fuel used.

Weight and balance terminology

<i>Datum</i>	“Reference datum” is an imaginary vertical plane from which all horizontal distances are measured for balance purposes.
<i>Arm</i>	is the horizontal distance of an item measured from the reference datum.
<i>Moment</i>	is the product of the weight of an item multiplied by its arm.
<i>C.G.</i>	<u>Center of Gravity</u> is the point at which the airplane, or equipment, would balance if suspended. Its distance from the reference datum is found by dividing the total moment by the total weight of the aircraft.
<i>Standard Empty Weight</i>	is the weight of the aircraft with engine fluids and oil at operating levels.
<i>Basic Empty Weight</i>	is the standard empty weight to which it is added the optional equipment weight.
<i>Useful Load</i>	is the difference between maximum takeoff weight and the basic empty weight.
<i>Maximum Takeoff Weight</i>	is the maximum weight approved to perform the takeoff.

INTENTIONALLY LEFT BLANK

10. UNIT CONVERSION CHART

<i>MULTIPLYING</i>		<i>BY →</i>	<i>YIELDS</i>	
TEMPERATURE				
Fahrenheit	[°F]	$\frac{5}{9} \cdot (F - 32)$	Celsius	[°C]
Celsius	[°C]	$\left(\frac{9}{5} \cdot C\right) + 32$	Fahrenheit	[°F]
FORCES				
Kilograms	[kg]	2.205	Pounds	[lbs]
Pounds	[lbs]	0.4536	Kilograms	[kg]
SPEED				
Meters per second	[m/s]	196.86	Feet per minute	[ft/min]
Feet per minute	[ft/min]	0.00508	Meters per second	[m/s]
Knots	[kts]	1.853	Kilometres / hour	[km/h]
Kilometres / hour	[km/h]	0.5396	Knots	[kts]
PRESSURE				
Atmosphere	[atm]	14.7	Pounds / sq. in	[psi]
Pounds / sq. in	[psi]	0.068	Atmosphere	[atm]
LENGTH				
Kilometres	[km]	0.5396	Nautical miles	[nm]
Nautical miles	[nm]	1.853	Kilometres	[km]
Meters	[m]	3.281	Feet	[ft]
Feet	[ft]	0.3048	Meters	[m]
Centimetres	[cm]	0.3937	Inches	[in]
Inches	[in]	2.540	Centimetres	[cm]
VOLUME				
Litres	[l]	0.2642	U.S. Gallons	[US Gal]
U.S. Gallons	[US Gal]	3.785	Litres	[l]
AREA				
Square meters	[m ²]	10.76	Square feet	[sq ft]
Square feet	[sq ft]	0.0929	Square meters	[m ²]

11. LITRES / US GALLONS CONVERSION CHART

Litres	US Gallons
5	1.3
10	2.6
15	4.0
20	5.3
25	6.6
30	7.9
35	9.2
40	10.6
45	11.9
50	13.2
60	15.9
70	18.5
80	21.1
90	23.8
100	26.4
110	29.1
120	31.7
130	34.3
140	37.7
150	39.6
160	42.3
170	44.9
180	47.6
190	50.2
200	52.8

US Gallons	Litres
1	3.8
2	7.6
3	11.4
4	15.1
6	22.7
8	30.3
10	37.9
12	45.4
14	53.0
16	60.6
18	68.1
20	75.7
22	83.3
24	90.9
26	98.4
28	106.0
30	113.6
32	121.1
34	128.7
36	136.3
38	143.8
40	151.4
45	170.3
50	189.3
55	208.2

SECTION 2 – LIMITATIONS

INDEX

1. INTRODUCTION	3
2. AIRSPEED LIMITATIONS.....	5
3. AIRSPEED INDICATOR MARKINGS.....	6
4. POWERPLANT LIMITATIONS	7
5. FUEL.....	8
6. LUBRICANT.....	8
7. COOLANT LIQUID	8
8. PAINT	8
9. PROPELLER.....	9
10. MAXIMUM OPERATING ALTITUDE.....	9
11. AMBIENT TEMPERATURE	9
12. POWERPLANT INSTRUMENTS MARKINGS	10
13. OTHER INSTRUMENTS MARKINGS	10
14. WEIGHTS	12
15. CENTER OF GRAVITY RANGE	14
16. APPROVED MANOEUVRES	16
17. MANOEUVRES LOAD FACTOR LIMITS	17
18. DEMONSTRATED CROSS WIND SAFE OPERATIONS	18
19. FLIGHT CREW.....	18
20. KINDS OF OPERATION EQUIPMENT LIST (KOEL)	19
21. LIMITATIONS PLACARDS.....	21
22. OTHER PLACARDS	23

INTENTIONALLY LEFT BLANK

1. INTRODUCTION

Section 2 includes operating limitations, instrument markings, and basic placards necessary for safe operation of the aeroplane, its engine, standard systems and standard equipment.

INTENTIONALLY LEFT BLANK

2. AIRSPEED LIMITATIONS

The following table addresses the airspeed limitations and their operational significance:

AIRSPEED		KIAS	KCAS	REMARKS
V _{NE}	Never exceed speed	145	141	Do not exceed this speed in any operation.
V _{NO}	Maximum Structural Cruising speed	113	111	Do not exceed this speed except in smooth air, and only with caution.
V _A	Design Manoeuvring speed	99	98	Do not make full or abrupt control movement above this speed, because under certain conditions the aircraft may be overstressed by full control movement.
V _O	Operating Manoeuvring speed			
V _{FE}	Maximum flaps extended speed	71	72	Do not exceed this speed for all flaps setting.

3. AIRSPEED INDICATOR MARKINGS

Airspeed indicator markings and their colour code are explained in the following table.

MARKING	KIAS	EXPLANATION
White arc/band	40 – 71	Positive Flap Operating Range (lower limit is V_{SO} , at specified maximum weight and upper limit is the maximum speed permissible with landing flaps extension).
Green arc/band	48 – 113	Normal Operating Range (lower limit is V_{S1} at specified maximum weight and most forward c.g. with flaps retracted and upper limit is maximum structural speed V_{NO}).
Yellow arc/band	113 – 145	Manoeuvres must be conducted with caution and only in smooth air.
Red line	145	Maximum speed for all operations.

4. POWERPLANT LIMITATIONS

Following table reports the powerplant operating limitations:

ENGINE MANUFACTURER: Bombardier Rotax GmbH.

ENGINE MODEL: 912 S2

MAXIMUM POWER:

	Max Power kW (<i>hp</i>)	Max rpm. Prop. rpm(<i>engine</i>)	Time max. (minutes)
Max. T.O.	73.5 (98.6)	2388 (5800)	5
Max. Cont.	69 (92.5)	2265 (5500)	-

Temperatures:

Max CHT*	135° C
Max CT	120° C
Min/Max Oil	50° C / 130° C

* *applicable for Engines up to serial no. 4924543(included) and repaired engine which doesn't change the cylinder head n°3 with new one (part no. 413195)*

Oil Pressure:

Minimum	12psi	(below 1440 propeller rpm)
Maximum	102 psi	(above 1440 propeller rpm)



CAUTION

In event of cold starting operation, it is permitted a maximum oil pressure of 7 bar for a short period.

Engine starting: allowable temperature range

OAT Min	-25° C
OAT Max	+50° C

Fuel pressure:

Minimum	2.2 psi
Maximum	7.26 psi

5. FUEL

2 TANKS:	62 litres each one (16.38 US gallons)
MAXIMUM CAPACITY:	124 litres (32.76 US gallons)
MAXIMUM USABLE FUEL:	120 litres (32 US gallons)
APPROVED FUEL:	MOGAS ASTM D4814 (min RON 95/AKI 91) MOGAS EN 228 Super/Super plus (min. RON 95/AKI 91) AVGAS 100 LL (ASTM D910)



Prolonged use of Aviation Fuel Avgas 100LL results in greater wear of valve seats and greater combustion deposits inside cylinders due to higher lead content. Make reference to Rotax Maintenance Manual which prescribes dedicated checks due to the prolonged use of Avgas.

6. LUBRICANT

Refer to “Rotax Operators Manual” – last issue -, “Operating Media” Section and Rotax SI-912-016 last issue for list of recommended commercial brands and types.

7. COOLANT LIQUID

Refer to “Rotax Operators Manual” – last issue -, “Operating Media” Section.

NOTE: For the Engines affected by Rotax SB-912-066 R1, the waterless coolant is not permitted)

8. PAINT

To ensure that the temperature of the composite structure does not exceed limits, the outer surface of the airplane must be painted with white paint, except for areas of registration marks, placards, and ornament. Refer to Aircraft Maintenance Manual (AMM), Chapter 51, for specific paint requirements.

9. PROPELLER

MANUFACTURER:	GT Propeller
MODEL:	GT-2/173/VRR-FW101 SRTC
BLADES:	One-piece 2-blade, constructed of wood materials, protective layer of laminate.
TYPE:	Fixed pitch
DIAMETER:	1730 mm (no reduction is permitted)

10. MAXIMUM OPERATING ALTITUDE

Maximum operating altitude is 13000ft (3962 m) MSL.



CAUTION

Flight crew is required to use supplemental oxygen according to applicable Air Operation Rules.

11. AMBIENT TEMPERATURE

Ambient temperature: from -25°C to +50°C.



WARNING

Flight in expected and/or known icing conditions is forbidden.

12. POWERPLANT INSTRUMENTS MARKINGS

Powerplant instrument markings and their colour code significance are shown below:

INSTRUMENT		RED LINE Minimum limit	GREEN ARC Normal operating	YELLOW ARC Caution	RED LINE Maximum limit
Propeller	rpm	----	577 - 2265	2265 - 2388	2388
Oil temp.	°C	50	50-130	----	130
CHT*	°C	----	0-135	----	135
CT	°C	----	0-120**	----	120
Oil pressure	psi	OP LOW WARNING 12 psi	----	-----	102
Fuel press.	psi	FP LOW WARNING 2.2 psi	2.2-7.26	----	7.26

*- applicable for Engines up to serial no. 4924543(included) and repaired engine which doesn't change the cylinder head n°3 with new one (part no. 413195)

**- For aircraft equipped with Sorlini indicator, due to an indicator physical limitation, green arc starts from 50°C.

13. OTHER INSTRUMENTS MARKINGS

INSTRUMENT	RED ARC Minimum limit	GREEN ARC Normal operating	YELLOW ARC Caution	RED ARC Maximum limit
Voltmeter	10-10.5 Volt	12-16 Volt	--	16-16,5

INTENTIONALLY LEFT BLANK

14. WEIGHTS

Condition	Weight	
Maximum takeoff weight	630 kg	1388lb
Maximum landing weight	630 kg	1388lb

Baggage Compartment		
Maximum weight	20 kg	44lb
Maximum specific pressure	12,5 kg/dm ²	256 lbs/sq in

INTENTIONALLY LEFT BLANK

15. CENTER OF GRAVITY RANGE

Datum	Vertical plane tangent to the propeller flange (the aircraft must be levelled in the longitudinal plane)
Levelling	Refer to the seat track supporting beams (see procedure in Section 6)
Forward limit	1.841 m (20% MAC) aft of datum for all weights
Aft limit	1.978 m (30% MAC) aft of datum for all weights



The pilot is responsible for ensuring that the airplane is properly loaded. Refer to Section 6 for appropriate instructions.

INTENTIONALLY LEFT BLANK

16. APPROVED MANOEUVRES

The aircraft is certified in Normal Category in accordance with EASA CS-VLA regulation applying to aeroplanes intended for non-aerobatic operation only.

Non aerobatic operation includes:

- Any manoeuvre pertaining to “normal” flight
- Stalls (except whip stalls)
- Lazy eights
- Chandelles
- Steep turns in which the angle of bank is not more than 60°

Recommended entry speeds for each approved manoeuvre are as follows:

Manoeuvre	Speed [KIAS]
Lazy eight	99
Chandelle	113
Steep turn (max 60°)	99
Stall	Slow deceleration (1 kts/s)



Acrobatic manoeuvres, including spins and turns with angle of bank of more than 60°, are not approved for such a category.



Limit load factor could be exceeded by moving abruptly flight controls at their end run at a speed above V_A (Manoeuvring Speed: 99 KIAS).



Flight in expected and/or known icing conditions, in proximity of storms or in severe turbulence is forbidden.

17. MANOEUVRES LOAD FACTOR LIMITS

Manoeuvre load factors limits are as follows:

Positive	Negative
+ 4 g	- 2 g

Manoeuvre load factors limits with flaps extended are as follows:

Positive	Negative
+ 2 g	0 g

18. DEMONSTRATED CROSS WIND SAFE OPERATIONS

The aircraft controllability, during take-offs and landings, has been demonstrated with a cross wind components of *15kts*.

19. FLIGHT CREW

Minimum crew:	1 pilot
Maximum number of occupants:	2 people (including the pilot)

20. KINDS OF OPERATION EQUIPMENT LIST (KOEL)

This paragraph reports the KOEL table, concerning the equipment list required on board under CS-VLA regulations to allow flight operations in VFR Day.

Flight in VFR Day is permitted only if the prescribed equipment is installed and operational.

Additional equipment, or a different equipment list, for the intended operation may be required by national operational requirements and also depends on the airspace classification and route to be flown. The owner is responsible for fulfilling these requirements.

**NOTE**

Garmin G3X provides primary engine and electric system parameters information, supported by caution/warning lights in the annunciator panel and backup CHT/CT indicator.



Garmin G3X indeed is NOT intended to be used as primary reference for flight and navigation information but only provides information for increased situational awareness: primary flight information (altitude, airspeed and heading) is provided by analogue instruments.

Equipment	VFR Day
Analogue Altimeter	•
Analogue Airspeed Indicator	•
Magnetic Direction Indicator	•
Analogue Fuel Quantity Indicators	•
Analogue CHT/CT indicator	•
Garmin G3X suite	•
Transponder	•
Altitude Encoder	•
Slip indicator	•
Longitudinal Trim Indicator	•
Flap Position Indicator	•
COMM/NAV equipment	•
Audio Panel/Marker beacon	•
Landing/Taxi Light	
Strobe Lights	
NAV Lights	
Annunciator Panel	•
Breakers Panel	•
Stall warning system	•
First Aid Kit	•
Hand-held fire extinguisher	•
ELT	•
Pitot Heat	
Torch (with spare batteries)	
Cabin Light	

21. LIMITATIONS PLACARDS

The following limitation placards are placed in plain view on the pilot.

On the left side instrument panel, above on the left, it is placed the following placard reporting the speed limitations:

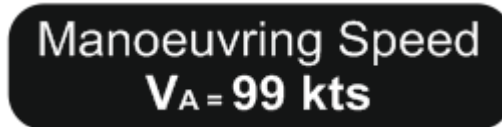

On the central side of the instrument panel, the following placard is placed reminding the observance of aircraft operating limitations according to installed equipment configuration (see KOEL, Para. 20):



On the right hand side of the instrument panel the following placard is placed reminding the observance for “no smoking”:



In the baggage compartment following placard is placed:

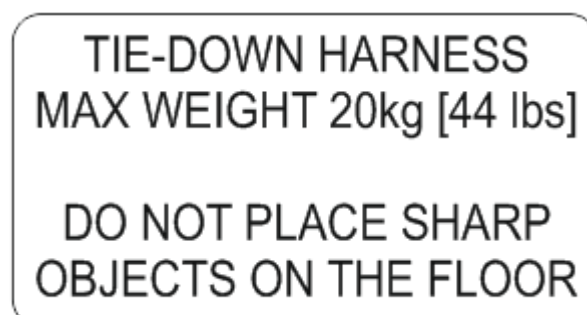

Below LH and RH Garmin G3X display and analogue instruments following placards are placed :



22. OTHER PLACARDS

Engine compartment placards

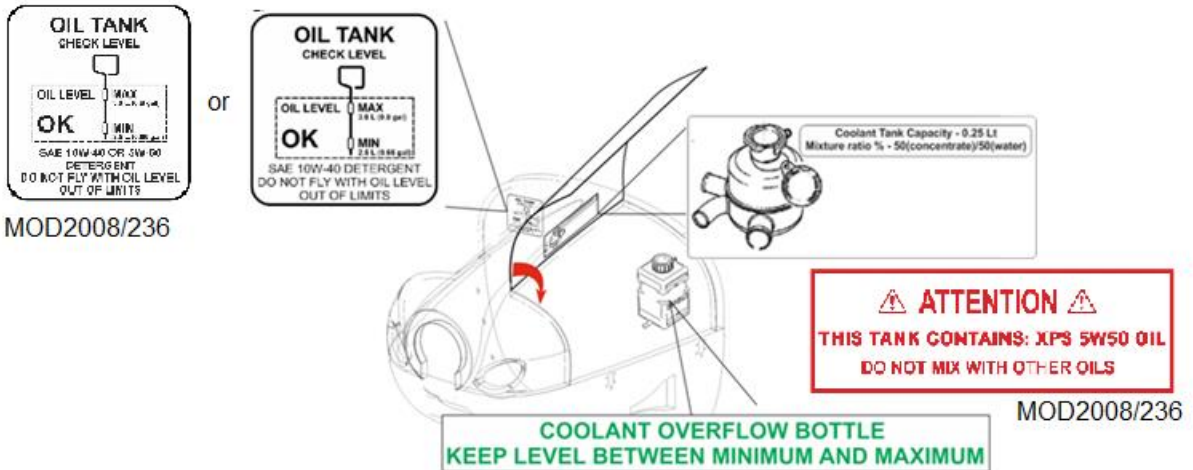

Oil brakes reservoir placard (applicable to aircraft not embodying MOD2008/132)

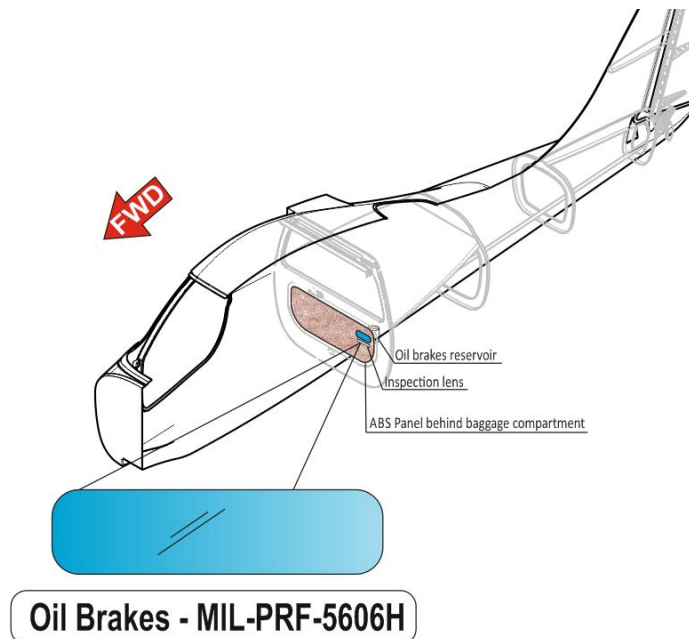

Usable fuel markings

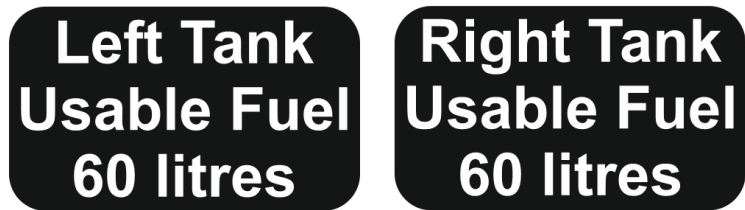

Allowed fuel placard

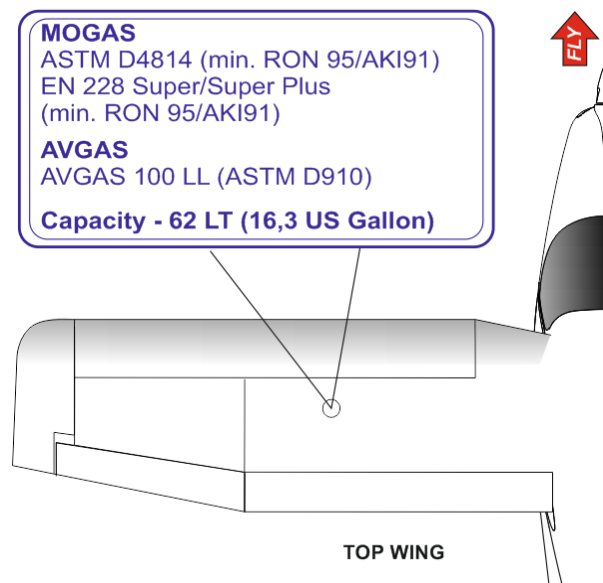

Emergency exit placard

EMERGENCY EXIT

Parking brake placard



Throttle marking

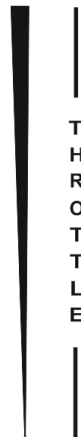

Fuel selector valve marking

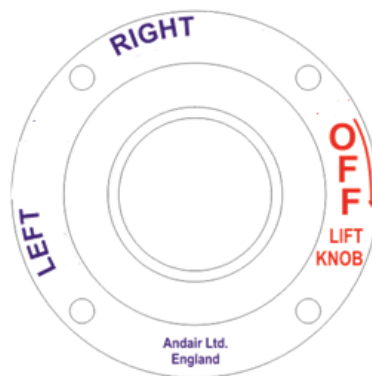

Choke placard



Or, for aircraft with G3X:



Cabin heat/defrost placard



Carb heat placard



Ignition key placard



Master/Generator placards



Flap indicator placard



or



(MOD2008/037)

Backrest lever placard

**BACKREST: PRESS
TO UNLOCK**

Safety equipment location placard

**FIRST AID KIT
FIRE EXTINGUISHER
are in the luggage
compartment**

Elt placard



Battery placard

**BATTERY INSIDE
BEHIND
THIS PANEL**

Annunciator panel



Upper panel labels

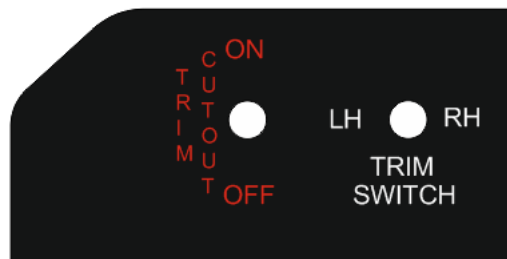

Switches labels



Door lock lever

CLOSED

OPEN

INTENTIONALLY LEFT BLANK

INTENTIONALLY LEFT BLANK

SECTION 3 – EMERGENCY PROCEDURES

INDEX

1. INTRODUCTION	3
2. AIRPLANE ALERTS	4
2.1. Electric Power System Malfunction	5
2.2. G3X Failures	6
2.3. Pitot Heating System Failure	7
3. AIRPLANE EVACUATION	8
4. ENGINE SECURING	8
5. ENGINE FAILURE	9
5.1. Engine Failure During Take-Off Run	9
5.2. Engine Failure Immediately After Take-off	9
5.3. Engine Failures During Flight	10
6. IN-FLIGHT ENGINE RESTART	14
7. SMOKE AND FIRE	15
7.1. Engine fire on the ground	15
7.2. Engine Fire During Takeoff.....	15
7.3. Engine Fire In-Flight	16
7.4. Cabin Fire / Electrical smoke in cabin during flight.....	16
7.5. Electrical smoke/fire in cabin on the ground	16
8. LANDING EMERGENCIES.....	17
8.1. Forced Landing Without Engine Power	17
8.2. Power-On Forced Landing	17
8.3. Landing With A Flat Nose Tire.....	17
8.4. Landing With A Flat Main Tire	18
9. RECOVERY FROM UNINTENTIONAL SPIN	19
10. OTHER EMERGENCIES.....	20
10.1. Unintentional Flight Into Icing Conditions	20
10.2. Trim System Failure	21
10.3. Flaps Failure	21

INTENTIONALLY LEFT BLANK

1. INTRODUCTION

Section 3 includes checklists and detailed procedures to be used in the event of emergencies. Emergencies caused by a malfunction of the aircraft or engine are extremely rare if appropriate maintenance and pre-flight inspections are carried out.

Before operating the aircraft, the pilot should become thoroughly familiar with the present Manual and, in particular, with the present Section. Further, a continued and appropriate training should and self-study should be done.

In case of emergency the pilot should acts as follows:

1. *Keep control of the aeroplane*
2. *Analyse the situation*
3. *Apply the pertinent procedure*
4. *Inform the Air Traffic Control if time and conditions allow.*

Two types of emergency procedures are hereby given:

- a. “Bold faces” which must be known by heart and executed in the correct and complete sequence, as soon as possible as the failure is detected and recognized;

These procedures characters are boxed and highlighted, an example is shown below:

<u>BEFORE ROTATION: ABORT TAKE OFF</u>	
1.	Throttle <i>IDLE</i>
2.	Rudder <i>Keep heading control</i>
3.	--
4.	--

- b. Other procedures which should be well theoretically know and mastered, but that are not time critical and can be executed entering and following step by step the AFM appropriate checklist.

NOTE

For the safe conduct of later flights, any anomaly and/or failure must be communicated to the National Authorities in charge, in order to put the aircraft in a fully operational and safe condition.

NOTE

In this Chapter, following definitions apply:

***Land as soon as possible:** land without delay at the nearest suitable area at which a safe approach and landing is assured.*

***Land as soon as practical:** land at the nearest approved landing area where suitable repairs can be made.*

2. AIRPLANE ALERTS

The alert lights, located on the instrument panel can have the following colours:

<u>GREEN</u>	to indicate that pertinent device is turned ON
<u>AMBER</u>	to indicate no-hazard situations that have to be considered and which require a proper crew action
<u>RED</u>	to indicate emergency conditions

2.1. ELECTRIC POWER SYSTEM MALFUNCTION

Alternator Failure Light ON



NOTE

Alternator light may illuminate for a faulty alternator or when voltage is above 16V; in this case the over-voltage sensor automatically shuts down the alternator.

If **ALTOUT** caution is **ON**:

1. Verify failure
2. Circuit breaker(s) *Check*
3. Generator switch: *OFF 1 sec. then back ON*

If **ALTOUT** caution persists **ON**:

4. Generator switch: *OFF*
5. *Reduce electrical load as much as possible*
6. **Land as soon as practical.**

NOTE

The battery can supply electrical power for at least 25 minutes.

2.2. G3X FAILURES

2.2.1. LH OR RH DISPLAY FAILURE

In case of LH or RH display failure, navigation and engine data will be automatically available in the remaining display (split mode).



INSTRUCTION: revert to the remaining display.

2.2.2. LOSS OF ENGINE PARAMETERS ON G3X

INSTRUCTION: refer to engine parameters warning lights (OP LOW and FP LOW) and CHT/CT backup indicator.

2.3. PITOT HEATING SYSTEM FAILURE

When the Pitot Heat system (if installed) is activated, the green **PITOT HEAT ON** safe operating annunciation is **ON**;

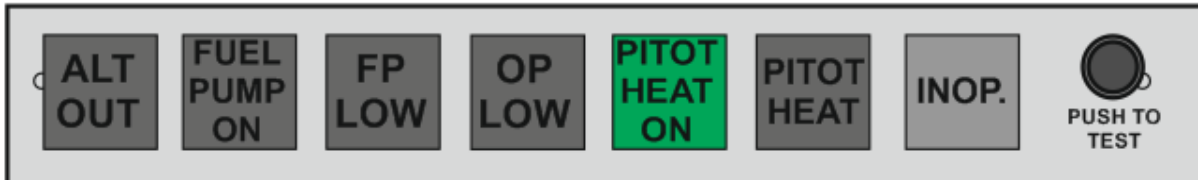

If the amber **PITOT HEAT** is turned ON, but the caution remains ON, the Pitot Heat system is not functioning properly.



In this case, apply following procedure:

1. Pitot Heat switch *OFF*
2. Check Pitot Heat circuit breaker *IN*
3. Pitot Heat switch *ON*
4. Check PITOT HEAT caution light:
If the amber light stays ON, assume PITOT HEAT malfunction.
Avoid visible moisture conditions.

3. AIRPLANE EVACUATION

With the engine secured and propeller stopped (if practical):

1. **Parking brake:** ***LOCK***
2. **Seat belts:** ***unstrap completely***
3. **Headphones:** ***REMOVE***
4. **Door:** ***OPEN***
5. ***Escape away from flames/ hot engine compartment/ spilling fuel tanks/ Hot brakes.***

4. ENGINE SECURING

Following procedure is applicable to shut-down the engine in flight:

1. **Throttle Lever** ***IDLE***
2. **Ignition key** ***OFF***
3. **Fuel Selector** ***OFF***
4. **Electrical fuel pump** ***OFF***
5. **Generator switch** ***OFF***

5. ENGINE FAILURE

5.1. ENGINE FAILURE DURING TAKE-OFF RUN

- | | |
|---------------------|------------------------------|
| 1. Throttle: | <i>IDLE (keep fully out)</i> |
| 2. Rudder: | <i>Keep heading control</i> |
| 3. Brakes: | <i>apply as needed</i> |

When safely stopped:

- | | |
|---------------------------------|-------------|
| 4. Ignition key: | <i>OFF.</i> |
| 5. Fuel selector valve: | <i>OFF</i> |
| 6. Electric fuel pump: | <i>OFF</i> |
| 7. Alternator& Master switches: | <i>OFF.</i> |

5.2. ENGINE FAILURE IMMEDIATELY AFTER TAKE-OFF

- | | |
|---|-----------------------------|
| 1. Speed: | <i>keep minimum 58 kias</i> |
| 2. Find a suitable place to land safely. | |



The immediate landing should be planned straight ahead with only small changes in directions not exceeding 45° to the left or 45° to the right.

- | | |
|------------------|------------------|
| 3. Flaps: | <i>as needed</i> |
|------------------|------------------|



Stall speed increases with bank angle and longitudinal load factor. Acoustic stall warning will in any case provides a correct anticipated cue of incipient stall.

At, or right before, touch down

- | | |
|--|----------------------------------|
| 4. Throttle: | <i>IDLE (fully out and hold)</i> |
| 5. Ignition key: | <i>OFF</i> |
| 6. Fuel selector valve: | <i>OFF</i> |
| 7. Electric fuel pump: | <i>OFF</i> |
| 8. Alternator& Master switches: | <i>OFF</i> |



A single engine aircraft take off should always be preceded by a thorough take off emergency pilot self-briefing. Decision to try an engine emergency restart right after take off should be taken only if environmental situation requires it: pilot shall never ignore the priority of attentively follow an immediate emergency landing.

After possible mechanical engine seizure, fire or a major propeller damage, engine restart attempt is not recommended.

5.3. ENGINE FAILURES DURING FLIGHT

5.3.1 Low Fuel Pressure



If the fuel pressure indicator falls below 2.2 psi/**FP LOW** warning is **ON**:

1. Electric fuel pump: *ON*
2. Fuel selector valve: *select opposite fuel tank if NOT empty*
3. Fuel quantity indicators: *Check both*

If fuel pressure does not build up:

4. **Land as soon as possible** applying forced landing procedure (See Para. 8)

5.3.2 Low Oil Pressure



If oil pressure is below 12 psi/**OP LOW** warning is **ON**:

1. Throttle Lever *REDUCE* to *minimum practical*
2. **Land as soon as practical**

If oil pressure does not increase and **OP LOW** persists **ON**:

3. **Land as soon as possible** applying forced landing procedure (See Para. 8)

5.3.3 High Oil Temperature

If **OP LOW** warning is **ON**, see para. 5.3.2 “Low Oil Pressure”.

If oil pressure is within limits:

1. Throttle Lever *REDUCE* to *Minimum practical*

If oil temperature does not decrease

2. Airspeed *INCREASE* if *practical*

NOTE

If oil temperature does not come back within limits, the thermostatic valve regulating the oil flow to the heat exchangers could be damaged, or an oil leakage can be present in the oil supply line.

3. **Land as soon as practical**

If engine roughness, vibrations, erratic behaviour, or high CHT/CT is detected:

4. **Land as soon as possible** applying forced landing procedure (See Para. 8)

5.3.4 CHT/CT limit exceedance

If CHT is above 135°C or CT is above 120°C, apply following procedure:

If **OP LOW** warning is **ON**, see para. 5.3.2 “Low Oil Pressure”.

If oil pressure is within limits:

1. Throttle Lever *REDUCE Minimum practical*
2. **Land as soon as practical**

NOTE

If CHT/CT does not come back within limits, the thermostatic valve regulating the water flow to the cylinder heads, could be damaged or a coolant leakage can be present in the coolant supply line.

If CHT/CT continues to rise and engine shows roughness or power loss:

3. **Land as soon as possible** applying forced landing procedure (See Para. 8)

6. IN-FLIGHT ENGINE RESTART



After a mechanical engine seizure, fire or a major propeller damage engine restart is not recommended.

- | | |
|----------------------------|--|
| 1. Carburettor heat | <i>ON if required</i> |
| 2. Electrical fuel pump | <i>ON</i> |
| 3. Fuel quantity indicator | <i>CHECK</i> |
| 4. Fuel Selector | <i>select opposite tank if not empty</i> |
| 5. Ignition key | <i>BOTH</i> |
| 6. Ignition key | <i>START</i> |
| 7. Throttle lever | <i>SET as required</i> |

In case of unsuccessful engine restart:

1. Engine *SECURE(see engine securing procedure on Para. 4)*
2. **Land as soon as possible** applying forced landing procedure (See Para. 8)

7. SMOKE AND FIRE

7.1. ENGINE FIRE ON THE GROUND

- | | |
|---------------------------------|------------------------------|
| 1. Fuel Selector | <i>OFF</i> |
| 2. Electrical fuel pump | <i>OFF</i> |
| 3. Ignition key | <i>OFF</i> |
| 4. Throttle lever | <i>FULL POWER</i> |
| 5. Cabin Heat | <i>OFF</i> |
| 6. Alternator & Master Switches | <i>OFF</i> |
| 7. Parking Brake | <i>LOCK</i> |
| 8. Aircraft Evacuation | <i>carry out immediately</i> |

7.2. ENGINE FIRE DURING TAKEOFF

BEFORE ROTATION: ABORT TAKE OFF

- | | |
|-------------------|----------------------------------|
| 1. Throttle Lever | <i>IDLE (fully out and hold)</i> |
| 2. Rudder | <i>Keep heading control</i> |
| 3. Brakes | <i>As required</i> |

With aircraft under control

- | | |
|---------------------------------|------------------------------|
| 1. Fuel Selector | <i>OFF</i> |
| 2. Electrical fuel pump | <i>OFF</i> |
| 3. Ignition key | <i>OFF</i> |
| 4. Cabin Heat | <i>OFF</i> |
| 5. Alternator & Master Switches | <i>OFF</i> |
| 6. Parking Brake | <i>LOCK</i> |
| 7. Aircraft Evacuation | <i>carry out immediately</i> |

7.3. ENGINE FIRE IN-FLIGHT

- | | | |
|----|-----------------------------|--|
| 1. | Cabin heat: | OFF |
| 2. | Fuel selector valve: | OFF |
| 3. | Electric fuel pump: | OFF |
| 4. | Throttle: | FULL FORWARD until the engine stops |
| 5. | Ignition key: | OFF |
| 6. | Cabin vents: | OPEN |



Do not attempt engine restart

7. **Land as soon as possible** applying forced landing procedure(See Para. 7).

7.4. CABIN FIRE / ELECTRICAL SMOKE IN CABIN DURING FLIGHT

- | | | |
|----|---|-------------|
| 1. | Cabin heating: | OFF |
| 2. | Cabin vents: | OPEN |
| 3. | Try to choke the fire. Direct the fire extinguisher towards flame base | |

If smoke persists:

- | | | |
|----|---|------------|
| 4. | Alternator& Master switches: | OFF |
| 5. | Land as soon as possible and evacuate the aircraft | |



If the MASTER SWITCH is set to OFF, consider that flaps extension and pitch trim operation is prevented.

7.5. ELECTRICAL SMOKE/FIRE IN CABIN ON THE GROUND

- | | | |
|----|-----------------------------|------------------------------|
| 1. | Generator switch: | OFF |
| 2. | Throttle Lever: | IDLE |
| 3. | Ignition key: | ALL OFF |
| 4. | Fuel Selector Valve: | OFF |
| 5. | Master Switch: | OFF |
| 6. | Aircraft Evacuation | carry out immediately |

8. LANDING EMERGENCIES

8.1. FORCED LANDING WITHOUT ENGINE POWER

1. Flaps: UP
2. Airspeed: 71 KIAS
3. Find a suitable place to land safely, plan to approach it upwind.
4. Fuel selector valve: OFF
5. Electric fuel pump: OFF
6. Ignition key: OFF
7. Safety belts: Tighten

When certain to land

8. Flaps: *as necessary*
9. Alternator and Master switches: OFF.

NOTE

Glide ratio is 12.8, therefore in zero wind conditions for every 1000 ft above Ground Level it is possible to cover ca. 2 NM.

8.2. POWER-ON FORCED LANDING

1. Airspeed: 71 KIAS
2. Flaps: UP
3. Locate the most suitable terrain for emergency landing, plan to approach it upwind.
4. Safety belts: Tighten

When certain to land, right before touch down

5. Flaps: *as necessary*
6. Fuel selector valve: OFF
7. Electric fuel pump: OFF
8. Ignition key: OFF
9. Alternator and Master switches: OFF

8.3. LANDING WITH A FLAT NOSE TIRE

1. Pre-landing checklist: Complete
2. Flaps: Land
3. Land and maintain aircraft *NOSE HIGH* attitude as long as possible.

As aircraft stops

4. Engine securing: Perform (see Para. 4)
5. Airplane evacuation: Perform (see Para. 3)

8.4. LANDING WITH A FLAT MAIN TIRE

If it's suspected a main tire defect or it's reported to be defective:

1. Pre-landing checklist: *Complete*
2. Flaps: *Land*
3. Land the aeroplane on the side of runway opposite to the defective tire to compensate the change in direction which is to be expected during final rolling
4. Touchdown with the GOOD TIRE FIRST and hold aircraft with the flat tire off the ground as long as possible by mean of aileron and rudder control.

As aircraft stops

5. Engine securing: *Perform (see Para. 4)*
6. Airplane evacuation: *Perform (see Para. 3)*

9. RECOVERY FROM UNINTENTIONAL SPIN

If unintentional spin occurs, the following recovery procedure should be used:

- | | |
|---------------------|--|
| 1. Throttle: | <i>IDLE (full out position and hold)</i> |
| 2. Rudder: | <i>full, in the opposite direction of the spin</i> |
| 3. Stick: | <i>centralize and hold neutral</i> |

As the spin stops:

- | | |
|-------------------------------|--|
| 4. Rudder: | <i>SET NEUTRAL</i> |
| 5. Aeroplane attitude: | <i>smoothly recover averting speeds in excess of V_{NE}</i> |
| 6. Throttle: | <i>Readjust to restore engine power.</i> |



*Keep full rudder against rotation until spin has stopped.
One complete turn and recovery takes about 500 feet.*

10. OTHER EMERGENCIES

10.1. UNINTENTIONAL FLIGHT INTO ICING CONDITIONS



WARNING

Airbox carburettor heater is designed to help prevent carburettor ice, less effectively functions as a de-icing system.

NOTE

See TECNAM SIL-2017-02 for further information about Carburettor Heating operation.



WARNING

In case of ice formation on wing leading edge, stall speed could highly increase and stall may become asymmetric. In case of stabilator ice accretion it may lose its efficiency, leading to aircraft pitch up response and loss of control.

1. Carburettor heating: *ON*
2. Immediately fly away from icing conditions (changing altitude and direction of flight, out and below of clouds, visible moisture, precipitations)
3. Controls surfaces: *continue to move to keep free from ice build up*
4. Throttle speed: *increase RPM*
5. Cabin heat: *ON*

10.2. TRIM SYSTEM FAILURE

Trim Jamming

Should trim control be inoperative, act as follows:

1. Breaker: *CHECK IN*
2. LH/RH Trim switch: *CHECK for correct position*

If jamming persists

1. Trim cutout switch: *CHECKON*
2. Speed: *adjust to control aircraft without excessive stick force*
3. **Land aircraft as soon as possible.**

Trim Runaway

In event of trim runaway, act as follows:

1. Trim cutout switch: *OFF*
2. Speed: *adjust to control aircraft without excessive stick force*
3. **Land aircraft as soon as possible.**

10.3. FLAPS FAILURE

In event of flaps-up landing, account for:

- Approach speed: *64 KIAS*
Landing length: *35% increased*

INTENTIONALLY LEFT BLANK

SECTION 4 – NORMAL PROCEDURES

INDEX

1.	INTRODUCTION.....	3
2.	AIRSPEEDS FOR NORMAL OPERATIONS.....	4
3.	PRE-FLIGHT INSPECTIONS.....	5
3.1.	Cabin Inspection.....	5
3.2.	Aircraft Walk-around.....	6
4.	CHECKLISTS.....	12
4.1.	Before Engine Starting (After Pre-flight Inspection).....	12
4.2.	Engine Starting.....	13
4.3.	Before taxiing.....	13
4.4.	Taxiing.....	14
4.5.	Prior to takeoff.....	14
4.6.	Takeoff and climb.....	15
4.7.	Cruise.....	15
4.8.	Before Landing.....	16
4.9.	Balked landing/missed approach.....	16
4.10.	After landing.....	16
4.11.	Engine shut down.....	17
4.12.	Post-flight checks.....	17

INTENTIONALLY LEFT BLANK

1. INTRODUCTION

Section 4 describes checklists and recommended procedures for the conduct of normal operations for *P2008 JC* aircraft.

**NOTE**

Garmin G3X provides primary engine and electric system parameters information, supported by caution/warning lights in the annunciator panel and backup CHT/CT indicator.

**NOTE**

Analogue CHT/CT is a backup for the information provided by G3X. Since the pick-up location for the CHT sensors is different (cylinder 2 and 4 respectively), analogue CHT could indicate a temperature up to 20° less than the G3X (in case of CT indicator, the sensor is only one).



Garmin G3X indeed is NOT intended to be used as primary reference for flight and navigation information but only provides information for increased situational awareness: primary flight information (altitude, airspeed and heading) is provided by analogue instruments.

2. AIRSPEEDS FOR NORMAL OPERATIONS

The following airspeeds are those which are significant for normal operations.

	FLAPS	630kg
Rotation Speed (V_R)	T/O	48 KIAS
Flap Retraction Speed (V_{OBS})	T/O	58 KIAS
Best Angle-of-Climb Speed (V_X)	0°	65 KIAS
Best Rate-of-Climb speed (V_Y)	0°	71 KIAS
Approach speed	T/O	58 KIAS
Final Approach Speed	FULL	54 KIAS
Touch Down Speed	FULL	54 KIAS
Manoeuvring speed (V_A)	0°	99 KIAS
Never Exceed Speed (V_{NE})	0°	145 KIAS

3. PRE-FLIGHT INSPECTIONS

Before each flight, it is necessary to carry out a complete aircraft check including a cabin inspection followed by an external inspection, as below detailed.

3.1. CABIN INSPECTION

- A Aircraft documents (ARC, Certificate of Airworthiness, Noise certificate, Radio COM certificate, AFM): *check current and on board*
- B Weight and balance: *calculate (ref. to Section 6) and check within limits*
- C Safety belts: *connected to hard points, check condition*
- D Ignition key: *OFF, key extracted*
- E Master switch: *ON*
- F Voltmeter: *check within the limits*
- G Lights: *all ON, check for operation*
- H Acoustic stall warning: *check for operation*
- I Master switch: *OFF*
- J Baggage: *check first aid kit, ELT, fire extinguisher, luggage secured with restraint net.*

3.2. AIRCRAFT WALK-AROUND

To perform the aircraft walk-around, carry out the checklists according to the pattern shown in Figure 4-1.



Visual inspection is defined as follows: check for defects, cracks, detachments, excessive play, unsafe or improper installation as well as for general condition. For control surfaces, visual inspection also involves additional check for freedom of movement and security. Red lubber lines on bolts and nuts shall be intact.



Fuel level indicated by the fuel quantity indicators must be verified by visual check of actual fuel quantity embarked in the tanks: graduated dipstick must be used.



If ignitions key is in L/R/BOTH position, a propeller movement can cause the engine starting with consequent hazard for people nearby.



Fuel drainage operation must be carried out with the aircraft parked on a level surface. Set Cockpit Fuel Selector Valve to ON prior to drain fuel.

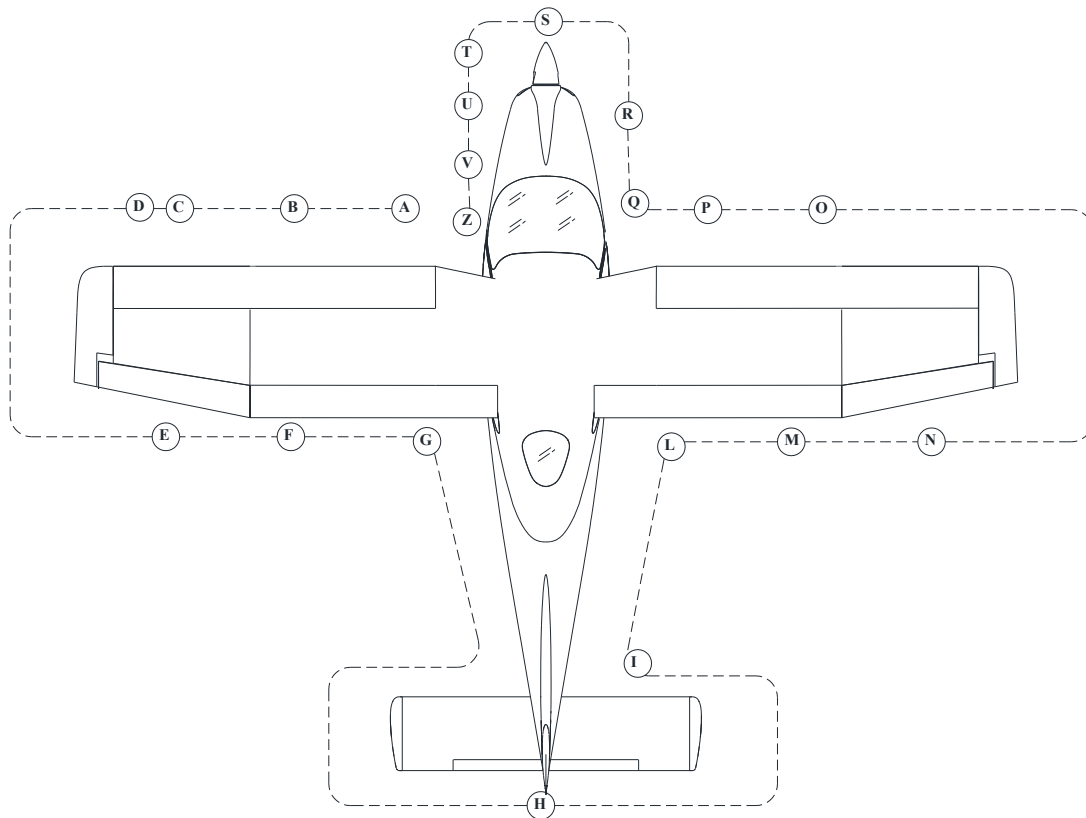

Figure 4.1

- | | | |
|----------|--|---|
| A | Left fuel filler cap | <i>CHECK desired fuel level (use graduated dipstick). Drain the left fuel tank sump by quick drain valve using a cup to collect fuel (drainage operation must be carried with the aircraft parked on a level surface). Check for water or other contaminants. Make sure filler cap is closed.</i> |
| B | Pitot tube | <i>REMOVE pitot plug and check the pitot for obstructions. Do not blow inside pitot tube.</i> |
| C | Left side leading edge and wing skin | <i>Visual inspection, CHECK stall strips</i> |
| D | Left strobe light | <i>Visual inspection, CHECK for integrity and fixing</i> |
| E | Left aileron, hinges and LH tank vent line | <i>CHECK for damage, freedom from plays; Left tank vent: CHECK for obstructions.</i> |
| F | Left flap and hinges | <i>Visual inspection</i> |

- G** Left main landing gear *CHECK inflation, tire condition, alignment, fuselage skin condition. Check fuselage skin status, tire status (cuts, bruises, cracks and excessive wear), slippage markers integrity, gear structure and brakes hoses: there should be no sign of hydraulic fluid leakage.*
- H** Stabilator and tab *CHECK stabilator leading edge. Check the actuating mechanism of stabilator and the connection with related tab: CHECK free of play, friction. CHECK fuselage bottom and top skin. CHECK antennas for integrity.*
- I** Vertical tail and rudder *Visual inspection, check free of play, friction.*
- L** Right main landing gear *CHECK inflation, tire condition, alignment, fuselage skin condition. Check fuselage skin status, tire status (cuts, bruises, cracks and excessive wear), slippage markers integrity, gear structure and brakes hoses: there should be no sign of hydraulic fluid leakage.*
- M** Right flap and hinges *Visual inspection*
- N** Right aileron, hinges and RH tank vent line *Visual inspection, check free of play, friction; Right side tank vent: check for obstructions.*
- O** Right strobe light, leading edge and wing skin *Visual inspection, CHECK stall strips, CHECK strobe light for integrity and fixing*
- P** Stall indicator switch *CHECK for integrity and free of play,*
- Q** Right fuel filler cap *CHECK desired fuel level (use graduated dipstick). Drain the right fuel tank sump by quick drain valve using a cup to collect fuel (drainage operation must be carried with the aircraft parked on a level surface). Check for water or other contaminants. Make sure filler cap is closed.*
- R** Nose wheel strut and tire/
RH static port *CHECK inflation, tire condition and condition of shock absorber: there should be no sign of hydraulic fluid leakage. Check the right static port for obstructions.*
- S** Propeller and spinner condition *CHECK for nicks, cracks, dents and other defects, propeller should rotate freely. Check fixing and lack of play between blades and hub.*

T Check the engine cowling surface conditions, then open engine inspection doors and perform the following checks:

- a) *Nacelle inlets and exhausts openings must be free of obstructions. Check connection and integrity of air intake system, visually inspect that ram air intake is unobstructed. If inlet and outlet plugs are installed, they must be removed.*
- b) *Check radiators. There should be no indication of leakage of fluid and they have to be free of obstructions.*
- c) *Check for foreign objects*
- d) *Only before the first flight of a day:*
 - (1) *Verify coolant level in the expansion tank, replenish as required up to top (level must be at least 2/3 of the expansion tank).*
 - (2) *Verify coolant level in the overflow bottle: level must be between min. and max. mark.*



WARNING

Before proceeding to the next step be sure that magnetos and Master switch are OFF with the key extracted.

- (3) *Turn the propeller by hand to and from, feeling the free rotation of 15° or 30° before the crankshaft starts to rotate. If the propeller can be turned between the dogs with practically no friction at all further investigation is necessary. Turn propeller by hand in direction of engine rotation several times and observe engine for odd noises or excessive resistance and normal compression.*
- (4) *Carburetors: check the throttle and choke cables for condition and installation.*
- (5) *Exhaust: inspect for damages, leakage and general condition.*
- (6) *Check engine mount and silent-blocks for condition.*
- e) *Check oil level and replenish as required. Prior to oil check, switch off both ignitions circuits and turn the propeller by hand in direction of engine rotation several times to pump oil from the engine into the oil tank, or let the engine idle for 1 minute. This process is finished when air is returning back to the oil tank and can be noticed by a murmur from the open oil tank. Prior to long flights oil should be added so that the oil level reaches the "max" mark.*
- f) *Drain off Gascolator for water and sediment (drain until no water comes off). Then make sure drain valve is closed.*
- g) *Check drainage hoses free of obstructions*
- h) *Verify all parts are fixed or locked: inspect fuel circuit for leakages.*

U Engine cowling doors *CLOSE, check for proper alignment of cam-locks*

V Landing/Taxi light and LH static port *CHECK, Visual inspection for integrity. Right side tank vent: check for obstructions.*

Z Tow bar and chocks

REMOVE, stow on board pitot, static ports and stall warning protective plugs.

Windshield and windows

INSPECT for cracks, erosion, crazing, visibility and cleanliness.

NOTE

Avoid blowing inside Pitot tube and inside airspeed indicator system's static ports as this may damage instruments.

INTENTIONALLY LEFT BLANK

4. CHECKLISTS

4.1. BEFORE ENGINE STARTING (AFTER PRE-FLIGHT INSPECTION)

1. Seat position and safety belts: *adjust*



In-flight seat release can cause the loss of airplane control. Check that occupied seats are positively locked: after seat adjustment, make sure that the adjustment lever is well aligned with the aircraft longitudinal axis (neutral position) and that has a springback return to the neutral position.

2. Flight controls: operate full stroke checking for movement smoothness, free of play and friction.
3. Parking Brake: LOCK
4. Throttle friction: *adjust*
5. Circuit Breakers: *check all IN*
6. Master switch: *ON, Check ALT OUT caution ON and check Voltmeter*
7. Pitot heating system (if installed): *make sure plug is removed, set to ON, CHECK advisory light ON. After about 5 seconds, turn OFF Pitot heating system. Check Pitot if warm.*
8. Electric fuel pump: *ON (check for audible pump noise)*
9. Electric fuel pump: *OFF*
10. Avionic Master switch: *ON, check instrument*
11. Flap control: *cycle fully extended and then set to T/O*
12. Pitch Trim: *cycle fully up and down, from both LH and RH controls, check for trim disconnect switch operation then set neutral.*



Pitch trim position other than in neutral position would affect take off performance and take off rotation execution at the correct V_R .

13. Nav. light & Strobe light: *ON*
14. Fuel quantity: *compare the fuel quantity indicators information with fuel quantity visually checked into the tanks (see Pre-flight inspection – External inspection)*

NOTE

In absence of RH seat occupant: fasten seat belts around the seat so as to prevent any interference with the aeroplane flight control operation and with rapid egress in an emergency.

15. Doors: *Closed and locked*



Avionic Master switch must be set OFF during the engine's start-up to prevent avionic equipment damage.

4.2. ENGINE STARTING

1. Throttle *IDLE*
2. Choke *AS NEEDED*
3. Fuel selector valve *SELECT the tank with less fuel*
4. Electric fuel pump *ON*
5. Propeller area *CALL for clear and visually check*



Check to insure no person or object is present in the area close to the propeller. Forward lower sector visibility is not possible from inside the cockpit.

6. External lights *AS REQUIRED*
7. Ignition key *START – EASY START message comes ON*
8. Check oil pressure rises within 10 sec.
9. Generator switch *ON – EASY START message comes OFF*
10. Voltmeter *CHECK more 14V or more*
11. Engine instruments *Check within the limits*
12. Choke *OFF*
13. RPM *1000-1200 prop. RPM*
14. Electric fuel pump *OFF*
15. Fuel pressure *CHECK within limits*

4.3. BEFORE TAXIING

1. Radio *ON*
2. Avionic Master *CHECK ON*
3. Altimeter *SET*
4. Landing light / Taxi light (if installed): *ON*
5. Parking Brake *FREE and taxi*

4.4. TAXIING

1. Brakes *CHECK*
2. Flight instruments *CHECK*

4.5. PRIOR TO TAKE OFF

1. Parking Brake *LOCK*
2. *Check engine parameters within limits and all caution/warning alerts OFF*
3. ALT OUT caution *CHECK OFF*
4. Electric Fuel pump *ON*
5. Fuel selector valve *SELECT the fullest tank*
6. Fuel pressure *CHECK*
7. Throttle *ADVANCE to 1640 prop. RPM*
 - a. Ignition key test *SELECT LEFT, check speed drop within 210 prop RPM;*
 - b. Select BOTH *CHECK propeller speed 1640 prop. RPM;*
 - c. Select RIGHT *CHECK speed drop within 210 prop. RPM;*
 - d. *Maximum difference of speed between LEFT and RIGHT 65 prop. RPM;*
 - e. Select BOTH *CHECK propeller speed 1640 prop. RPM.*
8. Carburettor heat test:
 - a. *Pull selector fully OUT*
 - b. RPM *CHECK within 100 prop. RPM drop*
 - c. *Push selector fully IN*
 - d. RPM *CHECK 1640 prop. RPM*
9. Throttle *Set to 1000-1200 prop. RPM*
10. Flaps position *T/O (15°)*
11. Pitch trim *CHECK neutral*
12. Flight controls *CHECK free*
13. Seat belts *CHECKED fastened*
14. Doors *CHECK closed and locked.*

4.6. TAKE-OFF AND CLIMB



Flight information provided by G3X is only for situational awareness. Refer to primary flight instruments.



On uncontrolled fields, before line up, check runway wind direction and speed and check for traffic on final.

- | | |
|--|--|
| 1. Landing light | <i>AS REQUIRED</i> |
| 2. Parking Brake | <i>FREE</i> |
| 3. Carburettor heat | <i>OFF</i> |
| 4. Throttle | <i>SET full forward and
check approximately 2100 ± 100 prop. RPM</i> |
| 5. Engine instruments | <i>CHECK parameters within limits</i> |
| <i>When V_R is reached</i> | |
| 6. Rotate | |
| 7. Flaps | <i>RETRACT (speed above V_{OBS})</i> |
| 8. Establish Climb rate | |
| 9. Landing and Taxi light (if installed) | <i>OFF</i> |
| 10. Electric fuel pump | <i>OFF</i> |
| 11. Fuel pressure | <i>CHECK within limits</i> |
| 12. Throttle | <i>REDUCE engine speed at or below 2250 prop. RPM</i> |

4.7. CRUISE

- | | |
|---------------------|--|
| 1. Throttle | <i>SET engine speed at or below 2250 prop. RPM</i> |
| 2. | <i>Check engine parameters within limits and all cautions/warnings OFF</i> |
| 3. Carburettor heat | <i>AS NEEDED</i> |

NOTE

Monitor and manually compensate asymmetrical fuel consumption by switching fuel selector valve. Switch on the electric fuel pump prior to swap the fuel feeding from one tank to another.

4.8. BEFORE LANDING

1. Electric fuel pump *ON*
2. Fuel valve *SELECT* the fullest tank
3. Landing Light *ON*

On downwind, leg abeam touch down point:

4. Flaps position *T/O*
5. Establish Approach Speed

On final leg:

6. Flaps *FULL*
7. Establish Final Approach Speed
8. Carburettor heat *OFF* (full IN)
9. Parking Brake *CHECK FREE*

4.9. BALKED LANDING / MISSED APPROACH

1. Throttle *FULL*
2. Attitude *Attain climb speed*

Only after positive climb rate is established:

3. Flaps *RETRACT*
4. Landing Light *OFF*
5. Electric fuel pump *OFF*
6. Throttle *REDUCE engine speed at or below 2250 prop. RPM*

4.10. AFTER LANDING

1. Flaps *UP*
2. Electric Fuel Pump *OFF*
3. Taxi Light (if installed) *ON when required*
4. Landing Light *OFF when required*

4.11. ENGINE SHUT DOWN

1. Parking brake *LOCK*
2. *Keep engine running at 1200 propeller RPM for about one minute in order to reduce latent heat*
3. Avionic equipment *OFF*
4. Ignition key *OFF, keys extracted*
5. All external lights *OFF*
6. Master & Generator switches *OFF*
7. Fuel selector valve *OFF*



WARNING

Before disembarkation verify propeller is fully stopped.



CAUTION

Instruct passenger to fully open RH door and depart, avoiding contact with wheels and sharp wing control surfaces edges.

4.12. POST-FLIGHT CHECKS

1. Flight controls *LOCK by mean of seat belts*
2. Wheel chocks *SET*
3. Wing mooring lines *SET*
4. Parking brake *FREE*
5. Doors *CLOSE and LOCK*
6. Protection plugs *SET over pitot tube, stall warning, static ports*

INTENTIONALLY LEFT BLANK

SECTION 5 - PERFORMANCE

INDEX

1. INTRODUCTION	2
2. USE OF PERFORMANCE CHARTS	2
3. AIRSPEED INDICATOR SYSTEM CALIBRATION	3
4. ICAO STANDARD ATMOSPHERE.....	4
5. STALL SPEED.....	5
6. CROSSWIND	6
7. TAKEOFF PERFORMANCE	7
8. TAKE-OFF RATE OF CLIMB.....	10
9. EN-ROUTE RATE OF CLIMB	11
10. CRUISE PERFORMANCE.....	12
11. LANDING PERFORMANCE	14
12. BALKED LANDING PERFORMANCE	15
13. NOISE DATA	15

1. INTRODUCTION

This section provides all necessary data for an accurate and comprehensive planning of flight activity from take-off to landing.

Data reported in graphs and/or in tables were determined using:

- ✓ “Flight Test Data” under conditions prescribed by EASA CS-VLA regulation
- ✓ aircraft and engine in good condition
- ✓ average piloting techniques

Each graph or table was determined according to ICAO Standard Atmosphere (ISA - s.l.); evaluations of the impact on performance were carried out by theoretical means for:

- ✓ Airspeed
- ✓ External temperature
- ✓ Altitude
- ✓ Weight
- ✓ Runway type and condition

2. USE OF PERFORMANCE CHARTS

Performance data are presented in tabular or graphical form to illustrate the effect of different variables such as altitude, temperature and weight. Given information is sufficient to plan the mission with required precision and safety.

Additional information is provided for each table or graph.

3. AIRSPEED INDICATOR SYSTEM CALIBRATION

Graph shows calibrated airspeed V_{IAS} as a function of indicated airspeed V_{CAS} .

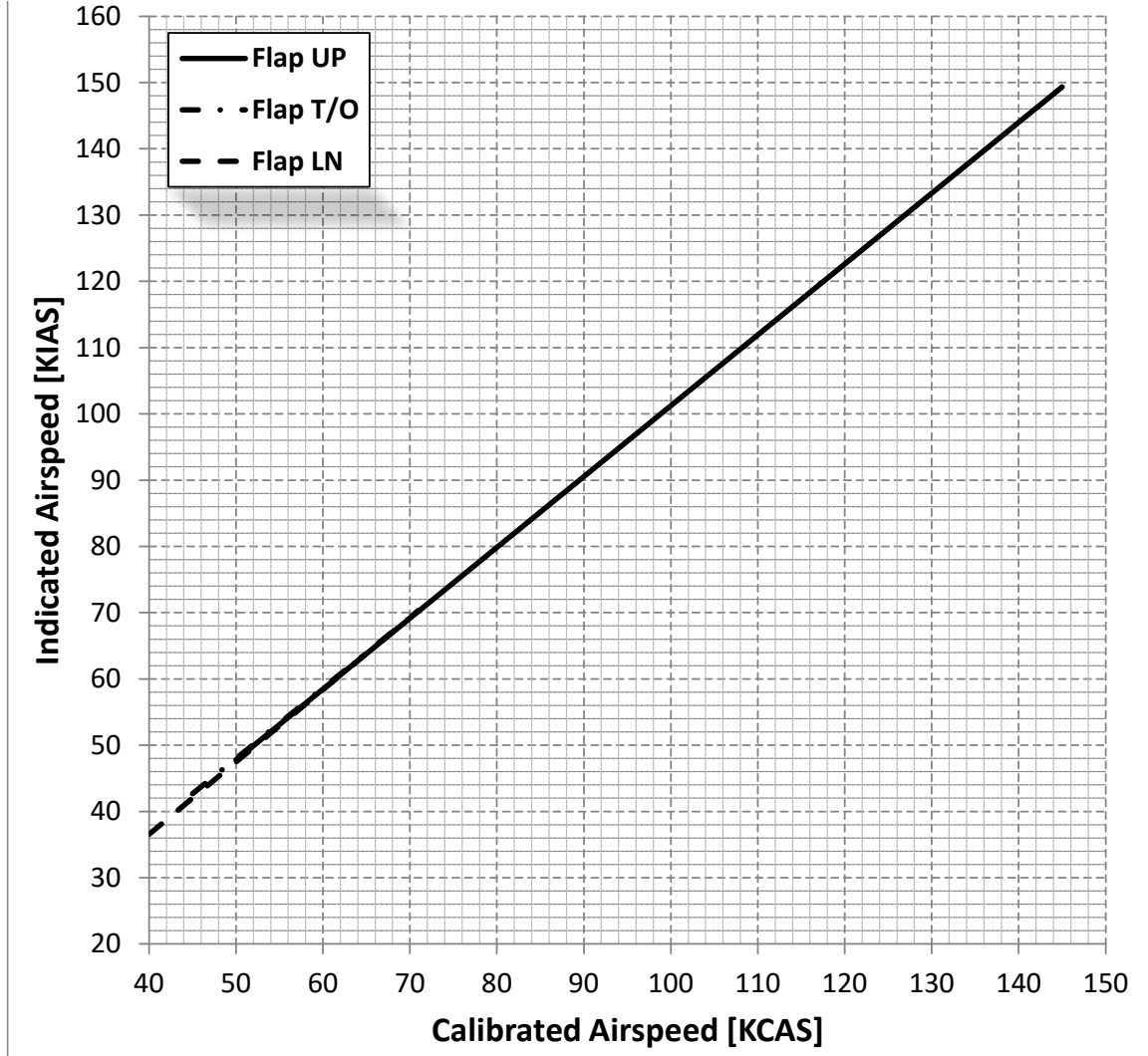

FIG. 5-1. CALIBRATED VS INDICATED AIRSPEED

Example:

Given

KIAS 75.0

Flap: UP

Find

KCAS 74.5

NOTE

Indicated airspeed assumes 0 as an instrument error

4. ICAO STANDARD ATMOSPHERE

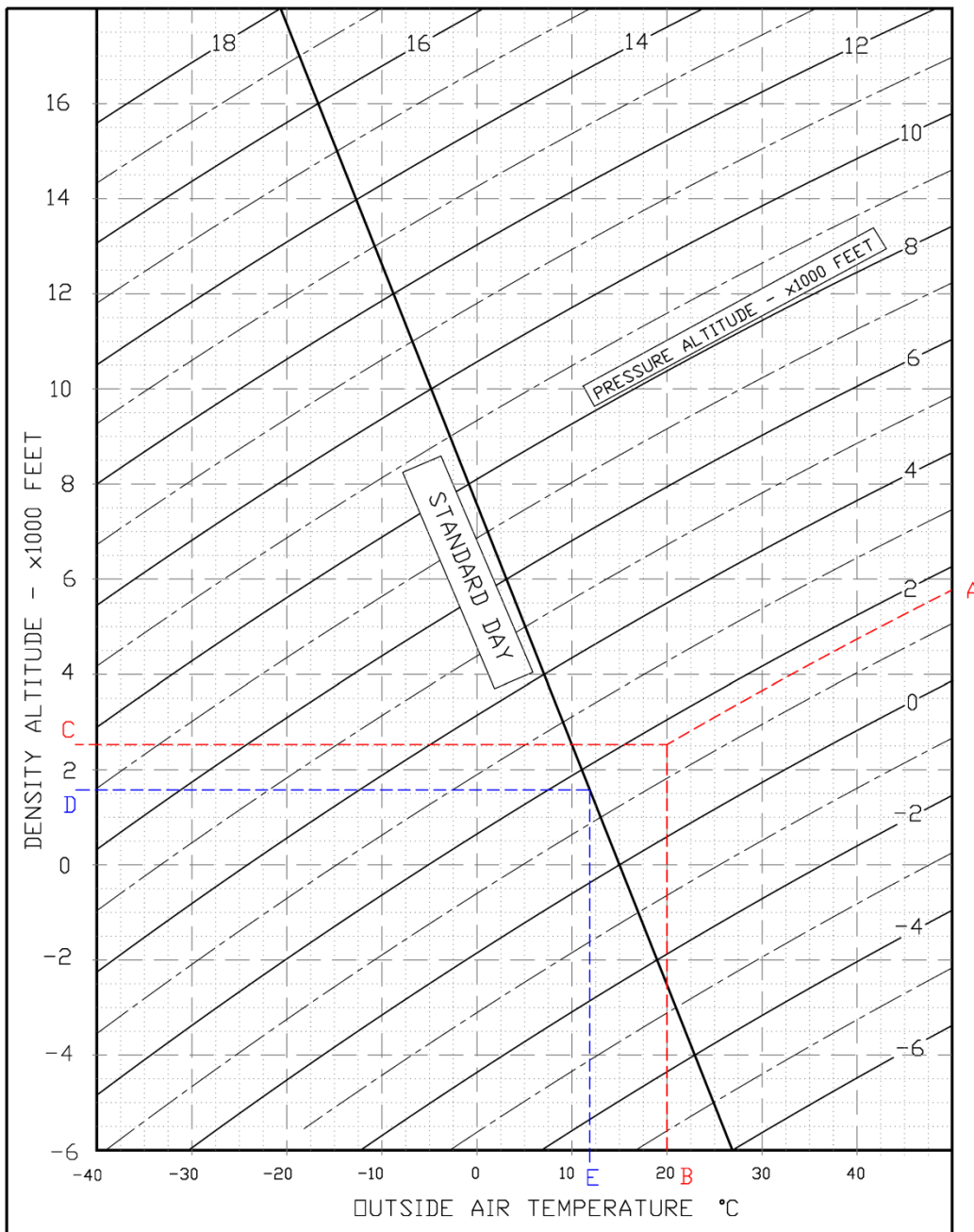

FIG. 5-2. ICAO CHART

Examples:

<u>Scope</u>	<u>Given</u>	<u>Find</u>
<u>DensityAltitude:</u>	A: Pressure altitude = 1600ft B: Temperature = 20°C	→ C: DensityAltitude = 2550ft
<u>ISA Temperature:</u>	D: Pressure altitude = 1600ft	→ E: ISA Air Temperature = 12°C

5. STALL SPEED

Weight: 630 kg Throttle Levers: IDLE CG: Most Forward (20%) No ground effect							
WEIGHT [kg]	BANK ANGLE [deg]	STALL SPEED					
		FLAPS 0°		FLAPS T/O		FLAPS FULL	
		KIAS	KCAS	KIAS	KCAS	KIAS	KCAS
630 (FWD C.G.)	0	48	50	43	46	40	43
	15	49	51	44	46	41	44
	30	52	54	47	49	44	46
	45	58	60	52	54	49	51
	60	70	71	63	64	60	61

NOTE

Altitude loss during conventional stall recovery, as demonstrated during flight tests is approximately 350 ft with banking below 30°.

6. CROSSWIND

Maximum demonstrated crosswind is 15Kts

⇒Example:

Given

Wind direction (with respect to aircraft longitudinal axis)= 30°

Wind speed = 20 Kts

Find

Headwind = 17.5 Kts

Crosswind = 10 Kts

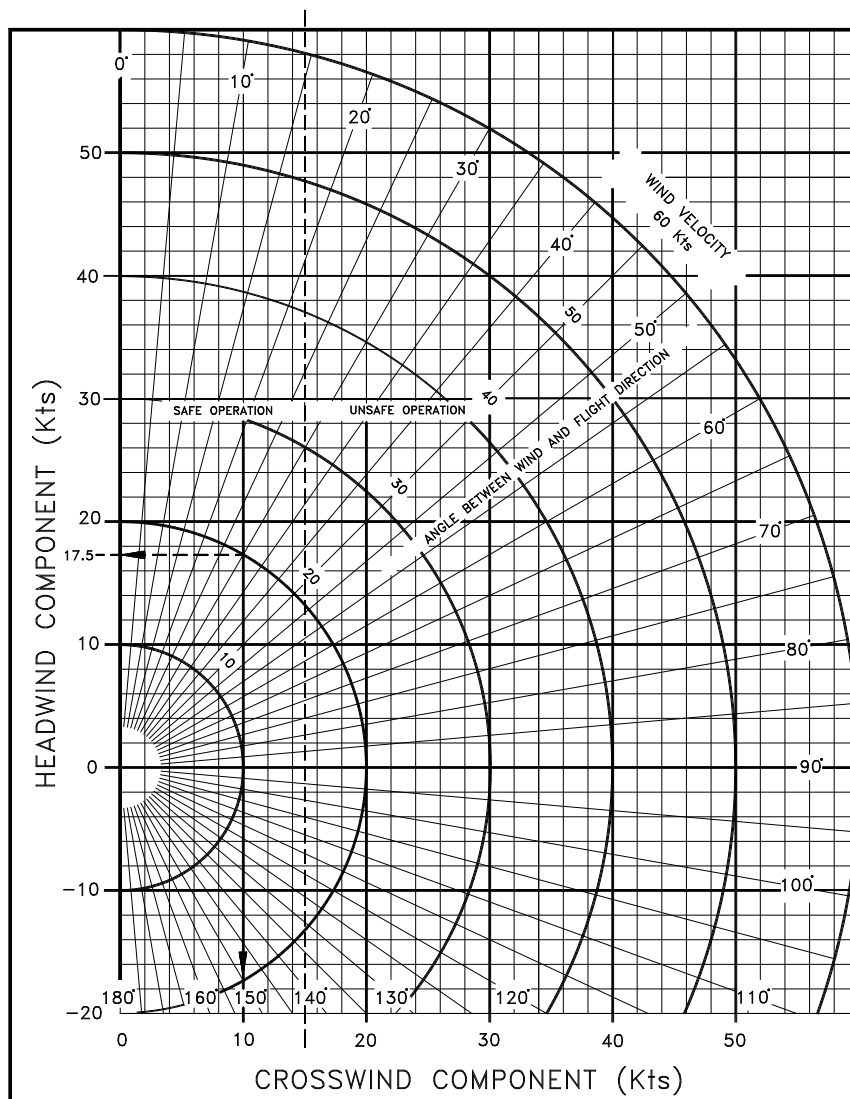

FIG. 5-2. CROSSWIND CHART

7. TAKEOFF PERFORMANCE

NOTE

To account for likely in service performance variations apply a factored to distances of 1.10

Weight = 630 kg		Corrections				
Flaps: T/O		Headwind: - 5m for each kt (16ft/kt)				
Speed at Lift-Off =48 KIAS		Tailwind: + 15m for each kt (49 ft/kt)				
Speed Over 50ft Obstacle =60KIAS		Paved Runway:-10% to Ground Roll				
Throttle Levers: Full Forward		Runway slope: +7% to Ground Roll for each +1%				
Runway: Grass						
Pressure Altitude [ft]		Distance [m]				
		Temperature [°C]				ISA
		-25	0	25	50	
S.L.	Ground Roll	157	198	244	296	225
	At 50 ft AGL	265	331	406	490	375
1000	Ground Roll	172	216	267	323	242
	At 50 ft AGL	289	361	442	533	402
2000	Ground Roll	187	236	291	353	259
	At 50 ft AGL	314	392	481	580	430
3000	Ground Roll	205	258	318	386	279
	At 50 ft AGL	342	427	524	631	461
4000	Ground Roll	224	281	347	421	299
	At 50 ft AGL	373	466	571	688	494
5000	Ground Roll	244	308	380	461	322
	At 50 ft AGL	406	508	622	750	530
6000	Ground Roll	268	337	416	504	346
	At 50 ft AGL	443	554	679	819	569
7000	Ground Roll	293	369	455	552	373
	At 50 ft AGL	484	605	741	894	611
8000	Ground Roll	321	404	499	605	401
	At 50 ft AGL	529	661	810	977	656
9000	Ground Roll	352	443	547	663	432
	At 50 ft AGL	578	722	885	1068	705
10000	Ground Roll	386	486	600	728	466
	At 50 ft AGL	632	790	969	1168	758

Pressure Altitude [ft]		Distance [m]				
		Temperature [°C]				ISA
		-25	0	25	50	
S.L.	Ground Roll	129	162	200	243	185
	At 50 ft AGL	219	274	335	404	310
1000	Ground Roll	141	177	219	265	198
	At 50 ft AGL	238	298	365	440	332
2000	Ground Roll	154	193	239	289	213
	At 50 ft AGL	259	324	397	478	355
3000	Ground Roll	168	211	261	316	228
	At 50 ft AGL	282	353	432	521	380
4000	Ground Roll	183	231	285	346	245
	At 50 ft AGL	308	384	471	568	408
5000	Ground Roll	200	252	311	378	264
	At 50 ft AGL	335	419	514	619	437
6000	Ground Roll	219	276	341	413	284
	At 50 ft AGL	366	457	560	676	469
7000	Ground Roll	240	302	373	453	305
	At 50 ft AGL	400	499	612	738	504
8000	Ground Roll	263	331	409	496	329
	At 50 ft AGL	436	545	668	806	541
9000	Ground Roll	289	363	448	544	354
	At 50 ft AGL	477	596	731	881	582
10000	Ground Roll	317	399	492	597	382
	At 50 ft AGL	522	652	799	964	626

Weight = 530 kg		Corrections				
Flaps: T/O		Headwind: - 5m for each kt (16ft/kt)				
Speed at Lift-Off = 48KIAS		Tailwind: + 15m for each kt (49 ft/kt)				
Speed Over 50ft Obstacle = 60 KIAS		Paved Runway: -10% to Ground Roll				
Throttle Levers: Full Forward		Runway slope: +7% to Ground Roll for each +1%				
Runway: Grass						
Pressure Altitude [ft]		Distance [m]				
		Temperature [°C]				ISA
		-25	0	25	50	
S.L.	Ground Roll	104	131	161	196	149
	At 50 ft AGL	178	222	272	328	251
1000	Ground Roll	113	143	176	214	160
	At 50 ft AGL	193	241	296	357	269
2000	Ground Roll	124	156	192	233	171
	At 50 ft AGL	210	263	322	388	288
3000	Ground Roll	135	170	210	255	184
	At 50 ft AGL	229	286	351	423	309
4000	Ground Roll	148	186	229	278	198
	At 50 ft AGL	250	312	382	461	331
5000	Ground Roll	161	203	251	304	213
	At 50 ft AGL	272	340	417	502	355
6000	Ground Roll	177	222	275	333	229
	At 50 ft AGL	297	371	455	548	381
7000	Ground Roll	194	244	301	365	246
	At 50 ft AGL	324	405	496	598	409
8000	Ground Roll	212	267	329	400	265
	At 50 ft AGL	354	442	542	654	439
9000	Ground Roll	232	293	361	438	285
	At 50 ft AGL	387	484	593	715	472
10000	Ground Roll	255	321	396	481	308
	At 50 ft AGL	423	529	648	782	508

8. TAKE-OFF RATE OF CLIMB

NOTE

To account for likely in service performance variations apply a factored to rate of climb of 0.90

Throttle Levers: Full Forward Flaps: Take-Off (15°)							
Weight [kg]	Pressure Altitude [ft]	Climb Speed V _y [KIAS]	Rate of Climb [ft/min]				ISA
			Temperature [°C]				
			-25	0	25	50	
630	S.L.	67	1055	870	706	558	770
	2000	66	915	733	572	426	660
	4000	66	775	597	438	295	550
	6000	65	636	461	305	164	441
	8000	64	497	325	172	34	331
	10000	64	359	190	40	-96	221
	12000	63	221	56	-92	-226	112
	14000	63	84	-79	-224	-355	2
580	S.L.	67	1182	987	814	657	881
	2000	66	1034	843	672	518	765
	4000	65	887	698	530	379	649
	6000	65	739	555	390	241	533
	8000	64	593	411	249	103	417
	10000	63	447	269	109	-34	302
	12000	63	301	126	-30	-171	186
	14000	62	156	-16	-169	-307	70
530	S.L.	66	1331	1123	937	770	1009
	2000	66	1173	968	786	622	886
	4000	65	1015	815	635	474	762
	6000	64	858	661	485	326	638
	8000	64	702	508	335	179	515
	10000	63	546	356	186	33	391
	12000	63	391	204	37	-113	268
	14000	62	236	53	-111	-259	144

9. EN-ROUTE RATE OF CLIMB

NOTE

To account for likely in service performance variations apply a factored to rate of climb of 0.90

Throttle Levers: Full Forward Flaps: UP							
Weight [kg]	Pressure Altitude [ft]	Climb Speed V _Y [KIAS]	Rate of Climb [ft/min]				ISA
			Temperature [°C]				
			-25	0	25	50	
630	S.L.	71	1045	894	759	637	811
	2000	70	930	782	649	529	721
	4000	68	816	670	539	422	631
	6000	67	702	558	430	314	541
	8000	65	588	447	321	207	451
	10000	64	474	336	212	101	362
	12000	62	361	225	104	-5	272
	14000	61	249	115	-4	-111	182
580	S.L.	71	1171	1011	869	740	924
	2000	69	1050	893	753	626	829
	4000	68	929	774	637	513	734
	6000	66	808	657	521	399	639
	8000	65	688	539	406	286	544
	10000	64	568	422	291	174	449
	12000	62	449	305	177	62	354
	14000	61	330	189	63	-50	259
530	S.L.	71	1317	1147	995	858	1054
	2000	69	1188	1021	871	737	953
	4000	68	1059	895	748	616	852
	6000	66	931	769	625	495	751
	8000	65	803	644	502	375	649
	10000	63	675	519	380	255	548
	12000	62	548	395	259	135	447
	14000	60	421	271	137	16	346

10. CRUISE PERFORMANCE



Propeller speed over 2265 RPM is restricted to 5min.

Weight = 630 kg							
CORRECTIONS							
	KTAS	Fuel Consumption	Endurance	Range	Specific Range		
For each +15°C of OAT	-2%	-2.5%	+2%	+1%	+1%		
For each -15°C of OAT	+1%	+3%	-4%	-2%	-1%		
For -100kg of weight	+3.3%	-	-	+3%	+4%		
CRUISE PERFORMANCE							
Pressure Altitude [ft]	OAT ISA [deg C]	Propeller RPM	KTAS	Fuel Consumption [lt/hr]	Endurance [hr:mm]	Range [nm]	Specific Range [nm/lt]
0	15	2388	120	25.8	4:40	562	4.64
		2250	110	21.3	5:40	624	5.16
		2100	99	17.4	7:00	689	5.70
		2000	92	15.3	7:50	725	5.99
		1900	85	13.7	8:45	748	6.18
		1800	78	12.5	9:40	751	6.21
2000	11	2388	118	24.1	5:00	593	4.90
		2250	108	20.0	6:00	653	5.40
		2100	98	16.6	7:20	712	5.89
		2000	90	14.8	8:10	740	6.12
		1900	83	13.4	9:00	752	6.22
		1800	76	12.4	9:45	743	6.15

Weight = 630 kg							
CORRECTIONS							
	KTAS	Fuel Consumption	Endurance	Range	Specific Range		
For each +15°C of OAT	-2%	-2.5%	+2%	+1%	+1%		
For each -15°C of OAT	+1%	+3%	-4%	-2%	-1%		
For -100kg of weight	+3.3%	-	-	+3%	+4%		
CRUISE PERFORMANCE							
Pressure Altitude [ft]	OAT ISA [deg C]	Propeller RPM	KTAS	Fuel Consumption [lt/hr]	Endurance [hr:mm]	Range [nm]	Specific Range [nm/lt]
4000	7	2388	117	22.6	5:25	624	5.16
		2250	107	18.9	6:25	681	5.63
		2100	96	15.9	7:35	731	6.04
		2000	89	14.3	8:25	750	6.20
		1900	82	13.2	9:10	750	6.21
		1800	75	12.4	9:45	728	6.02
6000	3	2250	105	18.0	6:40	706	5.84
		2100	94	15.3	7:50	744	6.16
		2000	87	14.0	8:35	753	6.22
		1900	80	13.1	9:25	741	6.13
		1800	73	12.5	9:40	705	5.83
8000	-1	2250	103	17.2	7:00	726	6.01
		2100	93	14.9	8:05	752	6.22
		2000	85	13.8	8:45	748	6.19
		1900	78	13.1	9:10	723	5.98
10000	-5	2100	91	14.6	8:20	752	6.22
		2000	84	13.7	8:45	735	6.08
		1900	76	13.3	9:05	698	5.77

11. LANDING PERFORMANCE

NOTE

To account for likely in service performance variations apply a factored to distances of 1.67

Pressure Altitude [ft]		Distance [m]				
		Temperature [°C]				ISA
		-25	0	25	50	
S.L.	Ground Roll	149	164	179	194	173
	At 50 ft AGL	358	373	388	403	382
1000	Ground Roll	154	170	186	201	178
	At 50 ft AGL	363	379	395	410	387
2000	Ground Roll	160	176	192	209	183
	At 50 ft AGL	369	385	401	418	392
3000	Ground Roll	166	183	200	216	189
	At 50 ft AGL	375	392	409	425	398
4000	Ground Roll	172	190	207	225	195
	At 50 ft AGL	381	399	416	434	404
5000	Ground Roll	179	197	215	233	201
	At 50 ft AGL	388	406	424	442	410
6000	Ground Roll	186	205	223	242	207
	At 50 ft AGL	395	414	432	451	416
7000	Ground Roll	193	212	232	251	213
	At 50 ft AGL	402	421	441	460	422
8000	Ground Roll	200	221	241	261	220
	At 50 ft AGL	410	430	450	470	429
9000	Ground Roll	208	229	250	271	227
	At 50 ft AGL	417	438	459	480	436
10000	Ground Roll	217	238	260	282	234
	At 50 ft AGL	426	447	469	491	443

12. BALKED LANDING PERFORMANCE

NOTE

To account for likely in service performance variations apply a factored to rate of climb and to angle of climb of 0.90

Throttle Levers: Full Forward							
Flaps: Take-Off (15°)							
Speed: 60 KIAS							
Weight [kg]	Pressure Altitude [ft]	Rate of Climb [ft/min] (angle of climb [deg])					
		Temperature [°C]				ISA	
		-25	0	25	50		
630	S.L.	881 (9°)	750 (7°)	633 (6°)	528 (5°)	678 (6°)	
	2000	781 (8°)	653 (6°)	538 (5°)	434 (4°)	600 (5°)	
	4000	682 (6°)	556 (5°)	443 (4°)	341 (3°)	523 (5°)	
	6000	583 (5°)	459 (4°)	348 (3°)	248 (2°)	445 (4°)	
	8000	485 (4°)	363 (3°)	254 (2°)	156 (1°)	367 (3°)	
	10000	387 (3°)	267 (2°)	160 (1°)	64 (0°)	289 (2°)	
	12000	289 (2°)	171 (1°)	66 (0°)	-28 (0°)	211 (2°)	
	14000	191 (1°)	76 (1°)	-27 (0°)	-120 (-1°)	133 (1°)	

13. NOISE DATA

Noise level, determined in accordance with ICAO/Annex 16 6th Ed., July 2011, Vol. I°, Chapter 10, is **69.83dB(A)**.

INTENTIONALLY LEFT BLANK

SECTION 6 – WEIGHT AND BALANCE

INDEX

1. INTRODUCTION	3
2. WEIGHING PROCEDURES	3
2.1. Preparation	3
2.2. Levelling	3
2.3. Weighing	3
2.4. Determination of C.G. location	4
2.5. Weighing record	5
2.6. Weighing record (II)	6
3. WEIGHTS AND C.G.	7
4. BAGGAGE LOADING	9
5. EQUIPMENT LIST	10

INTENTIONALLY LEFT BLANK

1. INTRODUCTION

This section describes the procedure for establishing the basic empty weight and the moment of the aircraft. Loading procedure information is also provided.

NOTE

Aircraft must be operated in accordance with the limits concerning the maximum takeoff weight and CG excursion as reported in Flight Manual Section 2.

Pilot is responsible for checking the weight and CG excursion are compliant with the related limits. CG excursion and weight limits are reported in Section 2 – Limitations.

2. WEIGHING PROCEDURES

2.1. PREPARATION

- Carry out weighing procedure inside closed hangar
- Remove from cabin any objects unintentionally left
- Insure Flight Manual and mandatory documents are on board
- Align nose wheel
- Drain fuel via the specific drain valve
- Oil, hydraulic fluid and coolant to operating levels
- Move sliding seats to most forward position
- Raise flaps to fully retracted position (0°)
- Place control surfaces in neutral position
- Place scales under each wheel

2.2. LEVELLING

- Level the aircraft (the reference for longitudinal levelling is made putting a spirit-level on the cabin floor as shown in the Aircraft Maintenance Manual).
- If needed, adjust longitudinal attitude deflating nose tire

2.3. WEIGHING

- Record weight shown on each scale
- Repeat weighing procedure three times
- Calculate empty weight

2.4. DETERMINATION OF C.G. LOCATION

- Drop a plumb bob tangent to the wing leading edge and trace a reference mark on the floor (see Figure on Para. 2.5 or 2.6)
- Repeat the operation for other wing
- Stretch a taught line between the two marks
- Measure the distance between the reference line and both main and nose wheel axis (A and B distances respectively)
- Using recorded data it is possible to determine the aircraft C.G. location and the aircraft moment (see following table)

2.5. WEIGHING RECORD

Model **P2008 JCS/N:** _____ Weighing no. _____ Date: _____

Datum: Propeller Flange

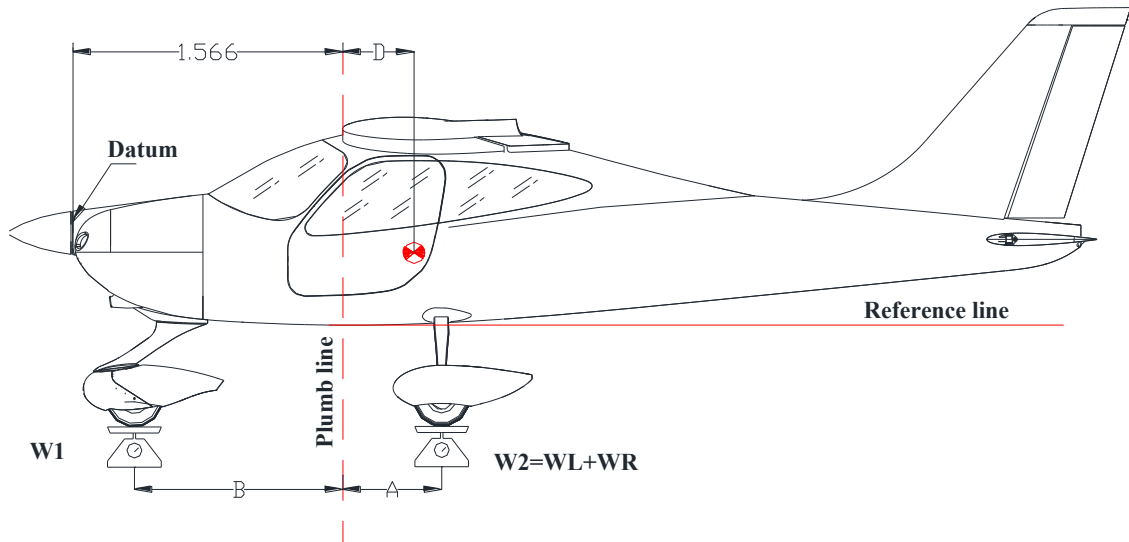

	<i>Kg or Lbs</i>		<i>Meters or feet</i>
Nose wheel weight	$W_1 =$	Plumb bob distance LH wheel	$A_L =$
LH wheel weight	$W_L =$	Plumb bob distance RH wheel	$A_R =$
RH wheel weight	$W_R =$	Average distance $(A_L + A_R)/2$	$A =$
$W_2 = W_L + W_R =$		Plumb bob distance from nose wheel	$B =$

Empty weight $W_e = W_1 + W_2 =$ _____ [kg] or [lbs]

$D = \frac{W_2 \cdot A - W_1 \cdot B}{W_e} =$ _____ [m] or [Ft] $D\% = \frac{D}{1.373 \text{ m (or 4.5 ft)}} \cdot 100 =$ _____

Empty weight moment: $M = [(D+1.566) \cdot W_e] =$ _____ [$m \cdot kg$] or [$ft \cdot lbs$]

Maximum takeoff weight	$W_T = 630 \text{ Kg}$ (1388 lbs)	Signature _____ _____
Empty weight	$W_e =$ _____ [kg] or [lbs]	
Max. useful load $W_T - W_e$	$W_u =$ _____ [kg] or [lbs]	

2.6. WEIGHING RECORD (II)

Model **P2008 JCS/N:** _____ Weighing no. _____ Date: _____

Datum: Propeller Flange

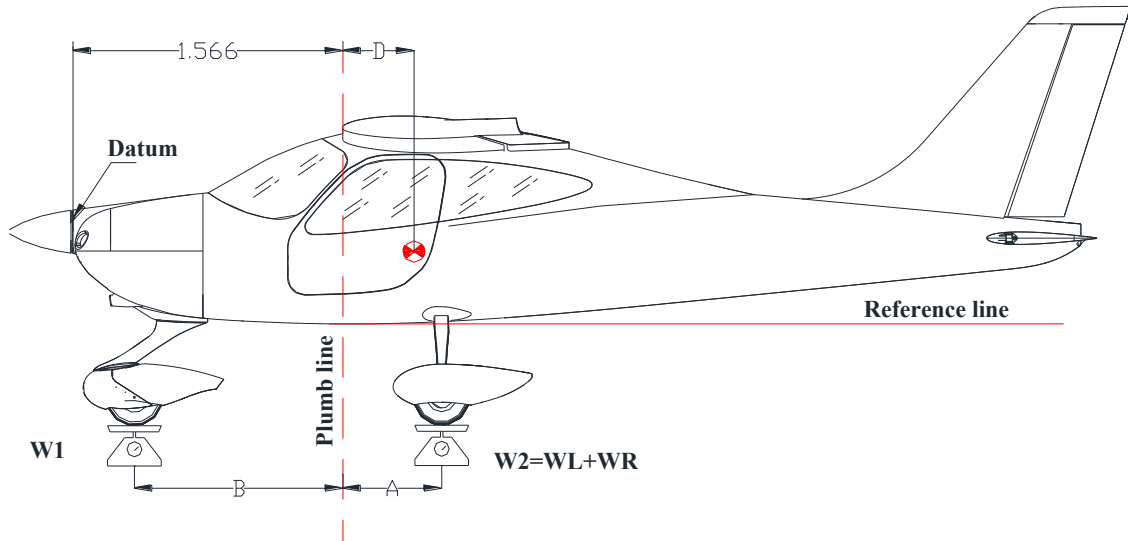

	<i>Kg or Lbs</i>		<i>Meters or feet</i>
Nose wheel weight	$W_1 =$	Plumb bob distance LH wheel	$A_L =$
LH wheel weight	$W_L =$	Plumb bob distance RH wheel	$A_R =$
RH wheel weight	$W_R =$	Average distance $(A_L + A_R)/2$	$A =$
$W_2 = W_L + W_R =$		Plumb bob distance from nose wheel	$B =$

Empty weight $W_e = W_1 + W_2 =$ _____ [kg] or [lbs]

$D = \frac{W_2 \cdot A - W_1 \cdot B}{W_e} =$ [m] or [ft]	$D\% = \frac{D}{1.373 \text{ m (or 4.5 ft)}} \cdot 100 =$
---	---

Empty weight moment: $M = [(D + 1.566) \cdot W_e] =$ _____ [$m \cdot kg$] or [$ft \cdot lbs$]

Maximum takeoff weight	$W_T = 630 \text{ Kg}$ (1388 lbs)	Signature _____ _____
Empty weight	$W_e =$ _____ [kg] or [lbs]	
Max. useful load $W_T - W_e$	$W_u =$ _____ [kg] or [lbs]	

3. WEIGHTS AND C.G.

In order to compute the weight and balance of this aircraft, the following loading charts are provided. To compute weight and balance use the formula:

$$\text{Weight} * \text{Arm} = \text{Moment.}$$

Pilot&Passenger	
Weight(kg)	Mo-ment (kgm)
10	18
20	36
30	54
40	72
50	90
60	108
70	126
80	144
90	162
100	180
110	198
120	216
130	234
140	252
150	270
160	288
170	306
180	324
190	342
200	360
210	378
220	396
230	414

Fuel		
Li-ter	Weight (kg)	Mo-ment (kgm)
10	7.2	15.91
20	14.4	31.82
30	21.6	47.74
40	28.8	63.65
50	36	79.56
60	43.2	95.47
70	50.4	111.38
80	57.6	127.30
90	64.8	143.21
100	72	159.12
110	79.2	174.95
120	86.4	190.86
124	89.3	197.26

Baggage	
Weight(kg)	Mo-ment (kgm)
5	12.05
10	24.10
15	36.15
20	48.20

	Meter	Inches
Pilot and PAX	1.800	70.90
FUEL	2.209	86.97
BAGGAGE	2.417	95.16

To compute weight and balance:

1. Get moments from loading charts
2. Obtain the empty weight and moment from the most recent weight and balance
3. Insert the weights and the moments for fuel, occupants and baggage from the previous chart
4. Sum the weight and the moment columns
5. Divide the total moment by the total weight to get the arm
6. Check that the total weight does not exceed maximum gross weight
7. Check that the arm falls within the C.G. range

CoG Position Computation Chart			
	Weight (kg)	Arm (m)*	Moment (kg*m)
EmptyWeight			
Fuel		2.209	
Pilot&Passenger		1.800	
Baggage		2.417	
Total MOMENT			
Total WEIGHT			
Distance "D"= MOMENT/WEIGHT			

*ADD to the distance "D" the value 1.566m (62in)

Signature

C.G.Range	Max FWD <i>m</i>	Max AFT <i>m</i>
	1.841	1.978

Max Weight	<i>lbs</i>	<i>kg</i>
	1320.00	630.00

Example						
	Weight		Arm		Moment	
	<i>lbs</i>	<i>kg</i>	<i>in</i>	<i>m</i>	<i>lbs in</i>	<i>kg m</i>
Empty	813.5	369.0	74.4	1.89	60533	697.4
Fuel	150.0	68.0	87.0	2.21	13052	150.4
Pax	300.0	136.1	70.9	1.80	21270	245.1
Baggage	0	0	94.9	2.41	0	0
Total	1263.5	573.1	75.1	1.91	94854	1092.8

In this example, the gross weight is under the max gross weight and the Arm or C.G. is within the C.G. range listed above.

4. BAGGAGE LOADING

The baggage loading in the dedicated compartment, behind the pilots' seats, must be carried out in accordance with C.G. excursion and weight limitations reported in Section 2.

Baggage must be uniformly distributed on compartment floor.

Pilot is provided with a red tie-down net and snap fasteners allowing for securing the loads on the compartment floor.



CAUTION

Loading the baggage, make sure that you correctly stretched the net which must be secured to the four vertices of the compartment.

5. EQUIPMENT LIST

The following is a comprehensive list of all TECNAM supplied equipment for the P2008 JC. The list consists of the following groups:

- A *Engine and accessories*
- B *Landing gear*
- C *Electrical system*
- D *Instruments*
- E *Avionics*

the following information describes each listing:

- Part-number to uniquely identify the item type.
- Item description
- Weight in kilograms
- Distance in meters from Datum

NOTE

Items marked with an asterisk () are part of basic installation. Equipment marked with X in the Inst. column are those actually installed on board relative to aircraft S/N.*

P2008 JC EQUIPMENT LIST		DATE:			
RIF.	DESCRIPTION & P/N	INST	WEIGHT [kg]	DATUM [mm]	Q.TY [N°]
ENGINE & ACCESSORIES					
A1	GT Propellers GT-2/173/VRR-FW101 SRTC		6.0	-144	1
	Hoffmann Propellers – HO17GHM A 174 177C		6.84	-144	1
	MTV-34-1-A/170-202		10.0	-144	1
A2	Heat exchanger 28-10-8000-000	*	2.00	754	1
A3	Oil Reservoir (full) 956508 or 956137	*	4.00	760	1
A4	Oil radiator 886029 or 886032	*	0.50	25	1
A5	Liquid coolant radiator 995.697 or 997084	*	1.50	129	1
A6	Air filter K&N 33-2544	*	0.40	315	1
A7	Electric Fuel pump 21-11-342-000 (478360) or 21-11-343-000 (476087)	*	1.20	764	1
A8	Thermostatic water valve 26-9-9100-000	*	0.35	316	1
A9	Thermostatic oil valve 26-9-9000-000	*	0.35	316	1
LANDING GEAR AND ACCESSORIES					
B1	Main gear rims Cleveland 40-78B or Beringer RF-005(B) or Cleveland 199-102	*	2.05	2229	2
B2	Main gear wheel assembly Beringer RF-018(c)		1.58	2229	2
B3	Main gear tires Air Trac 5.00-5 or Michelin PAA02 (pn 071-311-C) or Michelin 070-310-0	*	2.58	2229	2
B4	Disk brakes Cleveland 164-17 or Beringer EA-002N(A) or Beringer EA-002.50(A)	*	0.80	2229	2
B5	Nose gear wheel rim Beringer RA002(B) or Cleveland 0101120 or Cleveland 4077C or Beringer RA-014(B)	*	1.30	418	1
B6	Nose gear tire Air Trac 5.00-5 or Goodyear 505T08-1	*	1.20	418	1
B7	Nose gear tire Michelin 025-309-0		1.49	418	1
B8	Nose gear fairing 28-8-1110-1 / 28-8-1112-1		1.50	418	1
B9	Main gear fairing 92-8-410-1/2		1.50	2229	2
B10	Nose gear shock 28-8-500-000	*	1.45	770	1
ELECTRICAL SYSTEM					
C1	Battery FIAMM 6H4P 12V 18Ah		4.70	1900	1
C2	Battery GILL-Teledyne G-25 12V 18Ah		9.53	1900	1
C3	Buffer Battery Sonnenschein A512/2 S	*	1.0	1900	2
C3	Battery relay 111-226-5	*	0.30	1900	1
C4	Flaps actuator assy 22-5-176-1 or 28-5-2100-001	*	2.20	2206	1
C5	Trim actuator control BRISTOL SG B6(-)	*	0.15	5818	1
C6	Overvoltage sensor Electrodelta OS75-14		0.30	772	1
	Overvoltage sensor LAMAR B-00289-2		0.30	772	1
C7	Aveo NAV/POS/Strobe AVE-WPST R/G-54G	*	0.20	2130	2
C8	Landing led light PLEDIL or P36PIL		0.40	415	1

P2008 JC EQUIPMENT LIST		DATE:			
RIF.	DESCRIPTION & P/N	INST	WEIGHT [kg]	DATUM [mm]	Q.TY [N°]
C9	Aveo Landing/Taxi Light AVE-H16MWSSNH-00A		0.40	415	1
C10	Landing led light Whelen 01-0771833-10		0.40	415	1
C11	Landing/Taxi light Whelen 01-0772131-00		0.38	415	1
INSTRUMENTS					
D1	Altimeter Mikrotechna LUN 1128.12B6 TSO C10b		1.00	1084	1
D2	Airspeed ind Mikrotechna LUN 1116F2B2 TSO C2b		1.00	1084	1
D3	Compass – Airpath C2400 L4P – TSO C7c	*	0.29	1000	1
D4	Clock – DAVTRON mod. M 800	* ¹	0.15	1084	1
D5	Slip Indicator SI-2Q		0.56	1084	1
D6	Attitude Indicator - RC Allen Instr. RCA26EK-12		1.30	1084	1
D7	Trim Position Ind. UMA N0911S0U2DR000()	*	0.20	1084	1
D8	Fuel Quantity Ind. Road GmbH ID31.2B35.21	*	0.45	1090	2
D9	RPM indicator Sorlini SOR 52		0.30	1084	1
D10	Oil temperature indicator Sorlini SOR 54S		0.30	1084	1
D11	CHT temperature indicator Sorlini SOR 53		0.30	1084	1
D12	Voltmeter Sorlini SOR 51S	*	0.30	1084	1
D13	G3X Display (LH + RH) – P/n 28-9-5090-000		1.60	1084	2
D14	G3X AHRS - P/n 28-9-5110-000		1.60	1900	1
D15	G3X Magnetometer - GMU 44		0.23	4697	1
D16	OAT probe - GTP 59	*	0.10	2060	1
D17	CT temperature indicator Sorlini SOR 59		0.30	1084	1
D18	Turn and slip coordinator MD 5550-8340N3L		0.63	1084	1
D19	Primary Flight Instrument Mid Continent MD302		0.73	1084	1
D20	G3X Touch Display GDU 460 (LH + RH)		2.10	1084	2
AVIONICS AND OTHER					
E1	Nav/Comm Garmin SL30 Pack and connectors		1.50	1084	1
E2	ELT Artex ME 406		1.10	1900	1
E3	Transponder Garmin GTX328		1.00	1084	1
	Transponder Garmin GTX3X5		1.30	1084	1
E4	Audio panel Garmin GMA 340 or 345	*	0.50	1084	1
E5	Transponder Antenna Garmin 010-10160-00		0.17	985	1
E6	GPS Antenna Garmin GA-35 (for transponder)		0.27	807	1
	GPS Antenna Garmin GA-56		0.12	807	1
E7	Comm Antenna Comant Industries CI-121		0.34	4253	1
E8	ELT Antenna Kit Model ME 406		0.21	1900	1
E9	First Aid Kit	*	0.30	1800	1
E10	Garmin GNC 255A COM/NAV		1.80	1084	1
	Garmin GNC 215 NAV/COM		1.40		
E11	Marker beacon Antenna Comant Industries CI 102	*	0.30	2917	1
E12	Nav Antenna Comant Industries CI-158C	*	0.30	5782	1
E13	Altitude Encoder ACK technologies ACK A30		0.35	975	1
	Altitude Encoder Garmin GAE12		0.023	1084	1
E14	ELT Kannad 406 AF Compact or Integra or ACK Mod. E-04		1.10	1900	1

P2008 JC EQUIPMENT LIST		DATE:			
RIF.	DESCRIPTION & P/N	INST	WEIGHT [kg]	DATUM [mm]	Q.TY [N°]
E15	<i>ELT Antenna ANT200 or ACK Mod.E-04.8</i>		0.21	0.11	1
E16	<i>Transponder Antenna Comant industries CI 105</i>		0.12	985	1
	<i>Transponder Antenna RAMI AV-74</i>		0.091	985	1
E17	<i>COM Antenna Comant Industries CI291</i>		0.34	4253	1
E18	<i>ADC + ADAHRS Garmin GSU 25/25C</i>		0.22	2410	1
E19	<i>EIS Garmin GEA 24/GEA 24B⁴</i>		0.32	1070	1
E20	<i>Magnetometer Garmin GMU 22²</i>		0.16	3000	1
	<i>Magnetometer Garmin GMU11³</i>		0.16	3000	1
E21	<i>GARMIN GTR 225A/B COM radio</i>		1.39	1084	1
	<i>GARMIN GTR 205 COM radio</i>		1.40		1
E22	<i>COM Antenna Comant Industries CI 292-2</i>		0.27	4000	1
E23	<i>Fire Extinguisher H3Rs Halon RTA600</i>		0.60	1800	1
	<i>Fire Extinguisher Amerex A344</i>		1.50	1800	1
	<i>Fire Extinguisher Amerex A376T</i>		1.50	1800	1
E24	<i>KN63 (DME Receiver)</i>		1.27	2830	1
E25	<i>KDI572 (DME Indicator)</i>		0.36	1084	1
E26	<i>CI105-16 (DME Antenna)</i>		0.10	2917	1
E27	<i>KR87 (ADF Receiver)</i>		1.45	1084	1
E28	<i>KI227 (ADF Indicator)</i>		0.41	1084	1
E29	<i>KA44B (ADF Antenna)</i>		1.27	5027	1

1) CHRONOMETER IS A STANDARD EQUIPMENT ONLY FOR A/C NOT EMBODYING MOD2008/148.

2) APPLICABLE FOR AIRCRAFT EMBODYING MOD2008/037 OR MOD2008/081 AND NOT EMBODYING MOD2008/185

3) APPLICABLE FOR AIRCRAFT EMBODYING MOD2008/037 OR MOD2008/081 AND EMBODYING MOD2008/185

4) FOR AIRCRAFT EMBODYING MOD2008/193 GEA24B REPLACES GEA24

INTENTIONALLY LEFT BLANK

SECTION 7 – AIRFRAME AND SYSTEMS DESCRIPTION**INDEX**

1. INTRODUCTION	2
2. AIRFRAME	2
2.1. WING	2
2.2. FUSELAGE.....	3
2.3. EMPENNAGES	3
2.4. LANDING GEAR	4
3. FLIGHT CONTROLS.....	5
4. INSTRUMENT PANEL	6
4.1. CARBURETTOR HEAT	7
4.2. CABIN HEAT.....	7
5. SEATS AND SAFETY HARNESS	9
6. DOORS.....	9
7. POWERPLANT	10
7.1. ENGINE	10
7.2. PROPELLER	10
8. FUEL SYSTEM	11
9. ELECTRICAL SYSTEM.....	12
9.1. STALL WARNING SYSTEM.....	12
9.2. AVIONICS.....	13
9.3. EXTERNAL POWER SUPPLY.....	14
10. PITOT-STATIC PRESSURE SYSTEMS.....	15
11. BRAKES	16

1. INTRODUCTION

This section provides description and operation of the aircraft and its systems.

2. AIRFRAME

P2008 JC's airframe can be divided in the following main groups, as highlighted below on:

- 1) *Wings*
- 2) *Fuselage*
- 3) *Empennage*
- 4) *Landing gear*

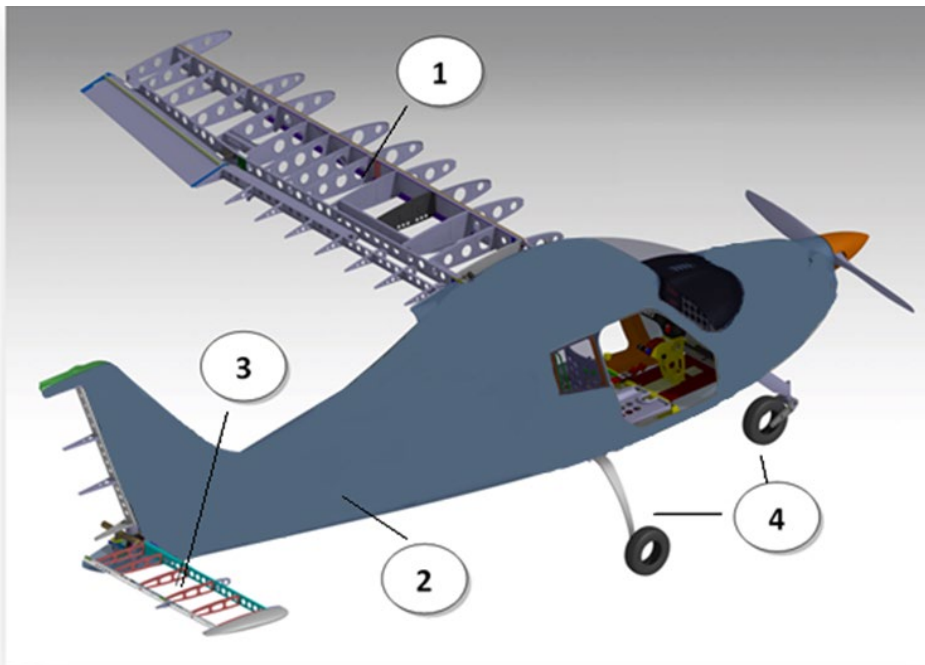

Fig. 7-1.P2008JC AIRFRAME

2.1. WING

Each wing is connected to the fuselage by means of two bolt attachments and a single strut brace per side. The wings are made up of a central light alloy torsion box; a light alloy leading edge is attached to the front spar whereas the flap (slotted) and the aileron ("frise") are attached to a rear spar through two hinges each. The torsion box consists of a front and rear spar that represent its front and rear vertical walls; a series of ribs and wrap-around panels complete the structure. Front and rear spars are integrated with wing-fuselage attachment fittings. The ailerons and flaps are made by an aluminium spar attached to a formed sheet metal leading edge and metal ribs; an aluminium skin surrounds the aileron structure.

2.2. FUSELAGE

The P2008 JC fuselage is mainly made by carbon fibres composite materials. The fuselage is made by two main shells that are later assembled bonding the two main bodies and the floor (composite) and adding aluminium stiffeners that allow the connection of the main landing gear, seats, wing and instrument panel. In this context the fuselage and vertical fin are a unique body.

2.3. EMPENNAGES

The horizontal tail is an all-moving type; the stabilizer and elevator form a single uniform plane called stabilator that rotates to the desired pitch setting. The stabilator structure is made-up by an aluminium spar (1) and ribs (2). Aluminium skin panels are riveted to the above elements (3). A trim tab (4) provides stick force adjustment and longitudinal compensation.

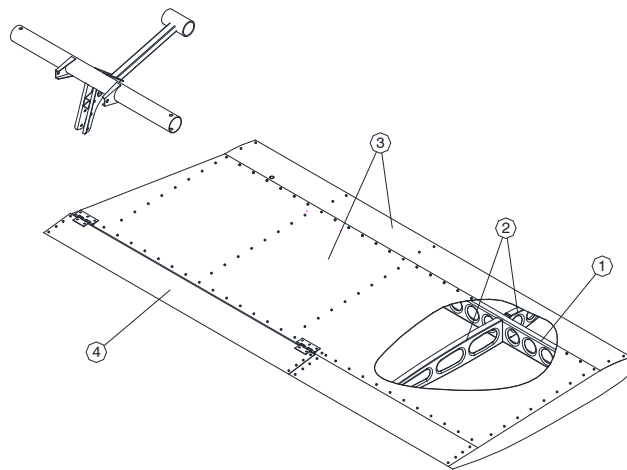

Fig. 7-2.STABILATOR STRUCTURE

The rudder structure is made-up by a single aluminium spar and ribs. Aluminium skin panels are riveted to the above elements. At the lower hinge a bellcrank is connected for the movement transmission.

2.4. LANDING GEAR

The main landing gear (see Figure 7-3) consists of two special steel leaf-springs positioned crossways to the fuselage.

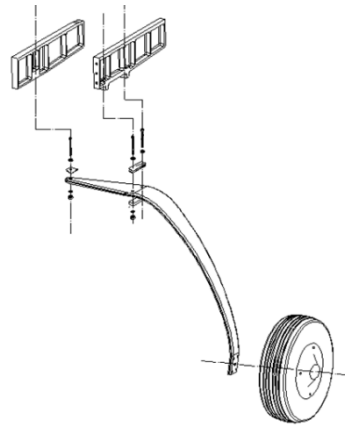

Fig. 7-3. MAIN LANDING GEAR STRUCTURE

The steel leaf-springs are attached to the fuselage structure via two couples of machined aluminium beams.

Wheels are cantilevered on gear struts and feature hydraulically actuated disc brakes controlled by toe.

A Pivoting nose gear is attached to the firewall reinforcement plate. The Hydraulic shock absorber is fitted on the upper machined component and directly on the nose landing gear structure.

In the following figure is shown:

- 1) Hydraulic shock absorber
- 2) Firewall
- 3) Nose wheel

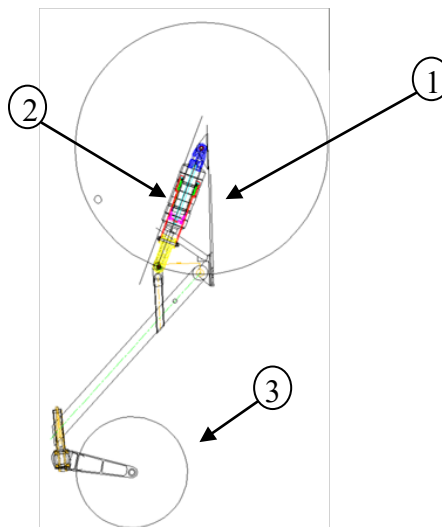

Fig. 7-4. NOSE LANDING GEAR STRUCTURE

3. FLIGHT CONTROLS

Aircraft flight controls are operated through conventional stick and rudder pedals. Longitudinal control acts through a system of push-rods and is equipped with a trim tab. a cable control circuit is confined within the cabin and it is connected to a pair of push-pull rod systems positioned in each main wing which control ailerons differentially. Aileron trimming is carried out on ground through a small tab positioned on left aileron.

Flaps are extended via an electric servo actuator controlled by a switch on the instrument panel. Flaps act in continuous mode; the indicator displays three markings related to 0°, takeoff (T/O) and landing (FULL) positions. A breaker positioned on the right side of the instrument panel protects the electric circuit.

Longitudinal trim is performed by the trim tab located on the stabilator through an electric actuator controlled by the pilot or co-pilot by a switch located on the control stick, another switch on the instrument panel, gives full authority to pilot or co-pilot control switch. An analogue trim indicator provides information about the surface position. In case of a trim control runaway a trim disconnect switch is available on the instrument panel.

4. INSTRUMENT PANEL

The instrument panel is divided in four areas:

- The left area holds primary (analogue) and pilot's situational awareness (G3X LH display) flight instruments, a chronometer and the pitch trim indicator;
- The right area holds engine and moving map indicator (G3X RH display), an analogue backup CHT indicator and breaker panel;

NOTE

Analogue CHT is a backup for the information provided by G3X. Since the pick-up location for the sensors is different (cylinder 2 and 4 respectively), analogue CHT could indicate a temperature up to 20° less than the G3X.

- The central area holds Nav/Com instrument, the transponder, warning lights, trim cut out switch and Trim LH/RH selector switch and the annunciator panel with following lights:
 - Electric fuel pump ON (GREEN)
 - Low Oil Pressure (RED)
 - Low Fuel Pressure (RED)
 - Alternator Fail (AMBER)
 - Pitot heat operation lights (GREEN/AMBER) - optional
- The lower-LH portion of the instrument panel holds:
 - Ignition key;
 - Master and Generator switches;
 - Emergency fuel pump;
 - Avionic Master switch;
 - Pitot heat switch (optionally provided);
 - Carburetor heat knob;
- The lower-Central portion of the instrument panel holds:
 - Throttle;
 - Two analogue fuel quantity indicators;
 - Fuel selector valve.
- The lower-RH portion of the instrument panel holds:
 - Flap indicator and control;
 - Cabin heating knob;
 - NAV, land and strobe switches.

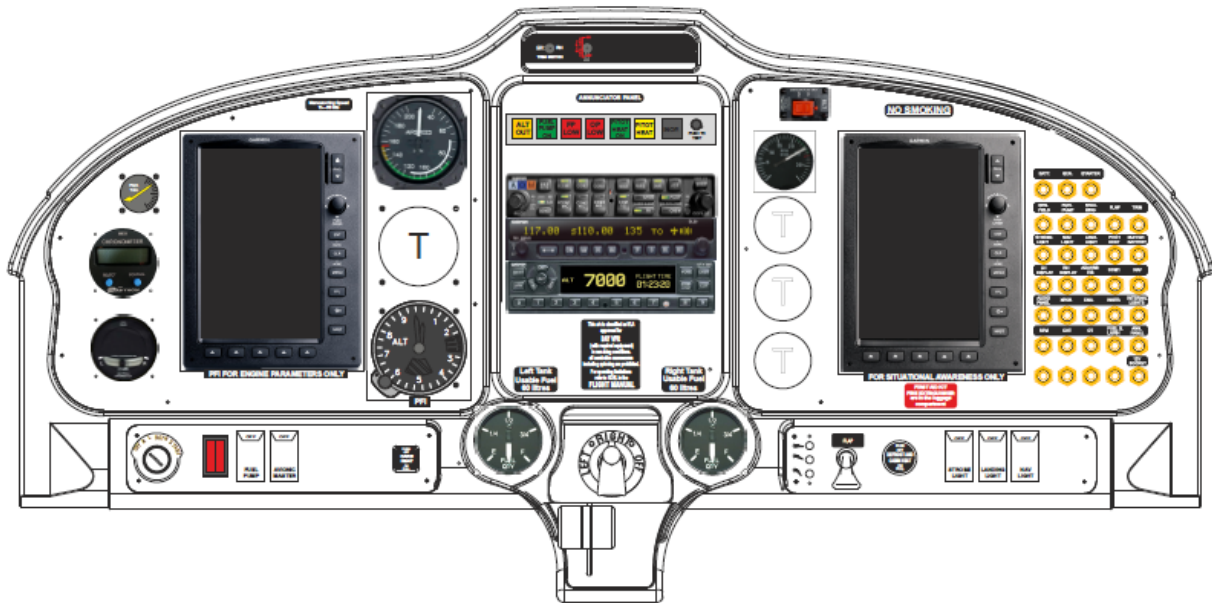

Fig. 7-5. INSTRUMENT PANEL

4.1. CARBURETTOR HEAT

Carburettor heat control knob is located lower-LH portion of the instrument panel; when the knob is pulled fully outward from the instrument panel, carburettors receive maximum hot air. During normal operation, the knob is set in OFF position.

4.2. CABIN HEAT

The cabin heat control knob is positioned on the lower right side of the instrument panel; when knob is pulled fully outward, cabin receives maximum hot air. If the outlets are kept closed, hot air only performs windshield defrost. Vents are located by the rudder pedals. If necessary, outside fresh air can be circulated inside cabin by opening the vents on the doors' windows.

INTENTIONALLY LEFT BLANK

5. SEATS AND SAFETY HARNESS

Aircraft features three fitting point for safety belts equipped with waist and shoulder harnesses adjustable via sliding metal buckle.

Seats are built with light alloy tube structure and synthetic material cushioning. A lever located on the right lower side of each seat allows for seat adjustment according to pilot size.

6. DOORS

Two doors are provided for P2008 JC, on Pilot and co-pilot side. A sketch of the door is shown below (RH and LH doors are specular):

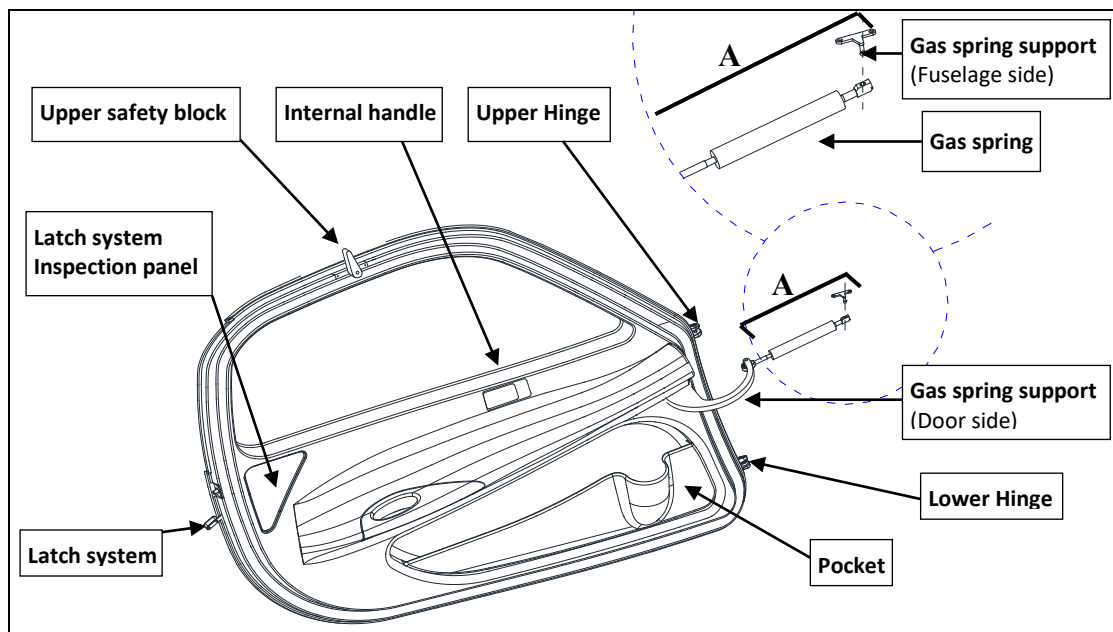

Fig. 7-6.DOOR

The door is equipped with a gas spring fixed to the fuselage that facilitates door opening.

7. POWERPLANT

7.1. ENGINE

Manufacturer: *Bombardier-Rotax GmbH*
Model: *ROTAX 912 S2*
Type: *4 stroke, horizontally-opposed 4 cylinder, mixed air and water cooled, twin electronic ignition, forced lubrication.*
Maximum rating: *98.6hp (73.5kW) @ 5800 rpm/min (2388 rpm/min. prop).
Gear reduction ratio - 2.4286:1*
Max oil consumption: *Max: 0.1 litres/hour*

7.2. PROPELLER

Manufacturer: *GT Propellers*
Model: *GT-2/173/VRR-FW101 SRTC*
N° of blades: *2*
Diameter: *1730 mm (no reduction permitted)*
Type: *wood, fixed pitch*

8. FUEL SYSTEM

The fuel system is designed to supply the reciprocating engine (Bombardier-Rotax 912 S2) with the suitable flow rate and pressure according to engine limitations required by Rotax.

Following figure shows the fuel system assy of P2008JC airplane.

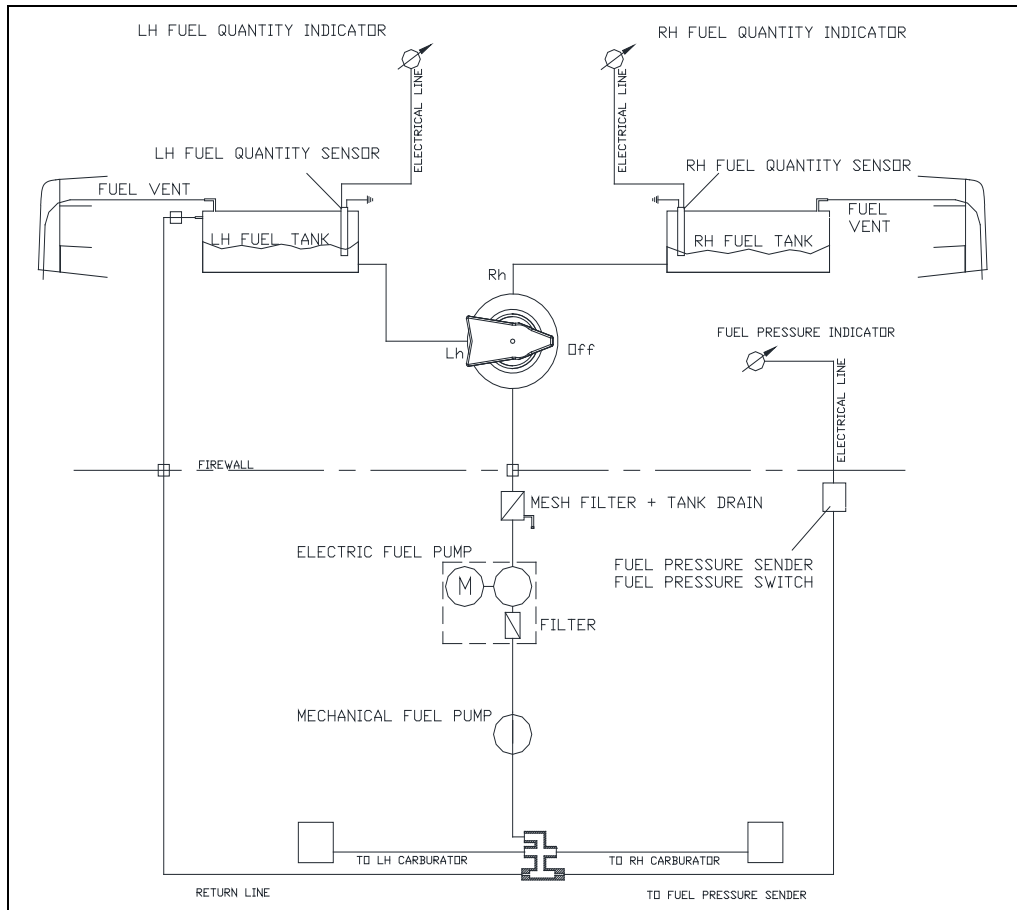

Fig.7-7. FUEL SYSTEM SCHEMATIC

Each fuel tank is integrated within the wing ribs box. The capacity of each tank is 62 liters for a total of 124 liters.

The internal side of fuel tank is accessible for inspection through two dedicated doors.

The fuel tank filler cap is located on the top of the wing, in the area outside of the tank and it is easily accessible from the leading edge of the aircraft. At the lowest point of the tank it is positioned a drain sump.

The engine is equipped with an engine gear pump, mechanical (primary). An additional auxiliary electrical fuel pump is provided (auxiliary).

The fuel selector is operated by a fuel selector control knob located in the cabin on the central panel. The fuel selector control and the fuel valve are connected via a rigid control rod.

9. ELECTRICAL SYSTEM

Primary DC power is provided by an external alternator with a 14 VDC output, rated to 40 Amps @ 5800 rpm. During normal operations, it recharges the battery.

Secondary DC power is provided by a battery (Main) which provides the energy necessary for feeding the essential electrical loads in the event of a alternator failure.

A second battery, activated only during engine start-up is installed; this is intended to act as a buffer battery during engine start-up, but it can provide additional electrical power in the event of an alternator failure or of a total loss of electrical system. This battery is enabled by the master switch and is only connected to the G3X units. It is installed beside the main battery and is housed in a dedicated box.

The switch between the energy sources (alternator and main battery) is automatic and no action is required in order to activate the alternate energy source.

For ground maintenance and/or starting, an external power socket is provided.

The alternator and battery are connected to the battery bus in order to provide energy for the electric equipment.

Each electrically fed instrument is connected to a dedicated circuit breaker which protects the cable from the battery bus to the associated electric equipment.



If the Ignition is in the position L, R, or BOTH, an accidental movement of the propeller may start the engine with possible danger for bystanders.

9.1. STALL WARNING SYSTEM

The aircraft is equipped with a stall warning system consisting of a sensor located on the right wing leading edge connected to a warning horn located near the instrument panel.

9.2. AVIONICS

The avionic system installed P2008 JC features four analogue indicators, an airspeed indicator, an altimeter, a magnetic compass and a slip indicator, which provide primary flight information.

Garmin G3X integrated avionic suite in a dual screen configuration is installed. It provides flight information intended for the pilot's situational awareness only. The suite provides primary engine information, except fuel quantity information which is provided by two dedicated analogue indicators located in the bottom central instruments panel, supplemented by an annunciator panel and analogue CHT indicator. G3X also embodies a GPS WAAS receiver whose information, intended for situational awareness only, are presented on RH display moving map.

Two dedicated indicators provide the pilot with information about the flaps and pitch trim position.

Stand-alone external COM/NAV and transponder sources (Garmin SL 30 and GTX 3XX) are installed. Garmin SL 30 Navigation information is presented on the display (course and direction) along with the information related to active/standby frequency. This information is supplemented by an HSI indicator on G3X LH display.

GTX 3XX transponder provides SSR (Secondary Surveillance Radar) responses; this unit is capable of both mode "S" and mode "C". An external altitude encoder (ACK A-30) allows altitude reporting, this information is also presented on GTX 3XX display.

For aircraft embodying MOD2008/200 Garmin Encoder GAE12 replaces ACK A-30 and the previous circuit breaker "ENCODER" installed is removed. Garmin GAE12 does not require any dedicated power supply because it is directly powered by GTX 3X5 transponder.

An automatic reversion mode is integrated within the system in order to continue providing the pilot with the flight and engine information in the event of a LH or RH display failure.

Four warning lights located on the top centre area of the instrument panel are available:

- Electric fuel pump ON (GREEN)
- Low Oil Pressure (RED)
- Low Fuel Pressure (RED)
- Alternator Fail (AMBER)

Two additional annunciator lights are installed when pitot heat system is optionally provided:

- Pitot heat ON (GREEN)
- Pitot heat fail (AMBER)

9.3. EXTERNAL POWER SUPPLY

On the right side of the tail cone, an external power is present. Using this device it is possible to feed the electric system directly on the bus bar, by an external power source. It should be used at the engine start-up in cold weather condition. For engine start below -17°C OAT it is advisable to use the external power source.

Follow this procedure to start the engine using the external power source.

1. Magnetos, Master switch, Generator switch: OFF
2. Open the receptacle door and insert the external power source's plug into the socket
3. Engine start-up procedure (see Sect. 4 in this manual)
4. Disconnect the external power source's plug and close firmly the receptacle door.

10. PITOT-STATIC PRESSURE SYSTEMS

The P2008 JC air speed/altitude indicating systems are connected with a Pitot-Static system based on a total pressure/Pitot probe (simple Pitot tube) mounted on left wing strut and two static pressure ports connected in parallel and located in correspondence of engine firewall on left and right side of fuselage. Flexible plumbing connects total pressure and static ports to primary analogue instruments, anemometer and altimeter.

Garmin G3X ADAHRS (GSU73) unit, installed on the rear of the fuselage near the battery, acts as an air data computer for Garmin G3X suite, it is connected to both static and total pressure lines providing on that suite both air speed and altitude information.

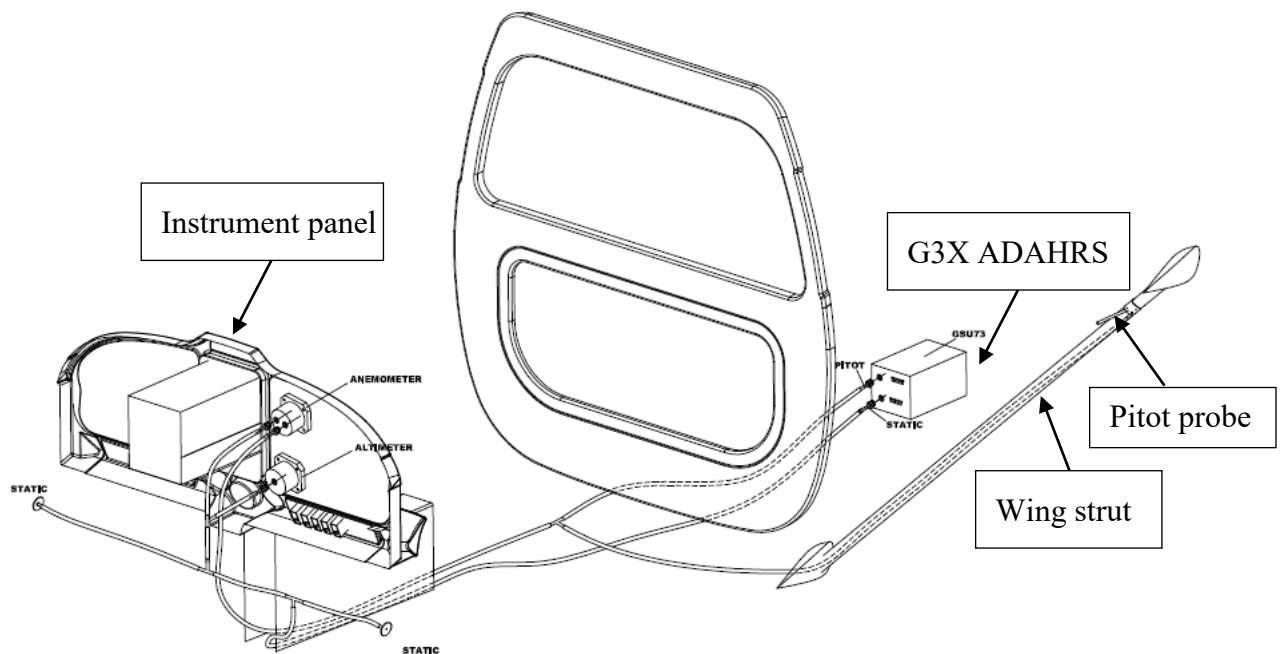

FIG.7-8. PITOT-STATIC SYSTEM

11. BRAKES

The P2008 JC is provided with an independent hydraulically actuated brake system for each main wheel. A master cylinder is attached to each pilot's rudder pedal. Hydraulic pressure, applied via the master cylinders, enters the brake via lines connected to the caliper.

A parking brake valve, mounted in correspondence of the cabin floor and operated by a knob on the cockpit central pedestal, intercepts the hydraulic lines, once pressurized by toe brakes, to hold the brake assemblies linings tightened round the main wheels brake discs. Brakes can be operated from either pilot's and co-pilot's pedals: a single vented oil reservoir feeds the pilot side master cylinders which are connected, via hoses, with the co-pilot's side ones.

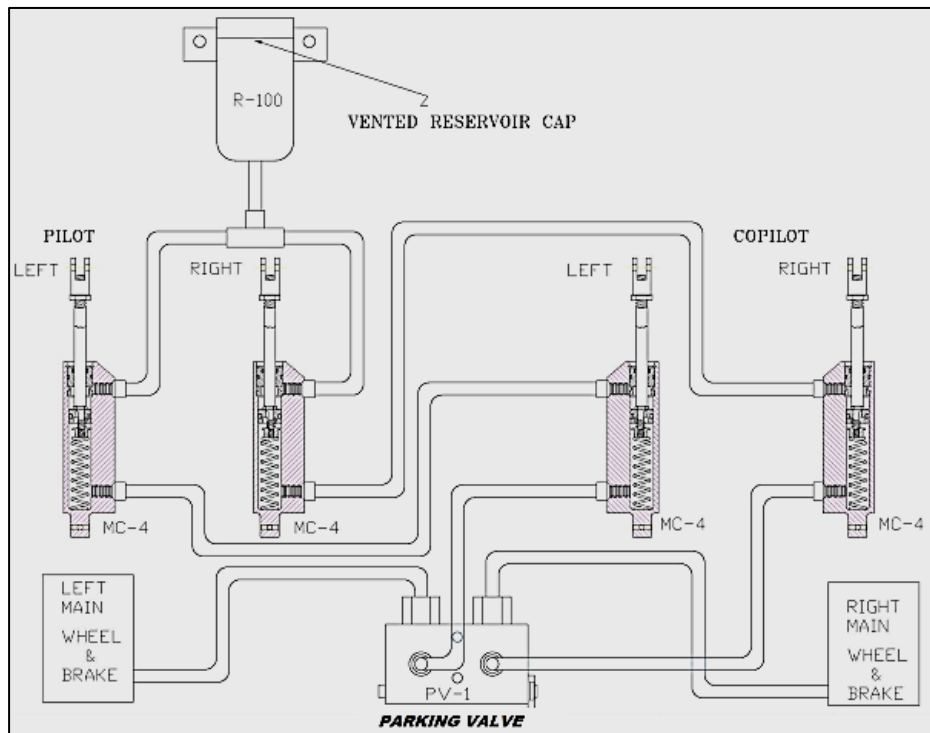

FIG. 7-9. BRAKE SYSTEM SCHEMATIC

If MOD2008/124 is embodied, the brake system is composed by two brake pumps MC-5 on pilot's side and two MC-4 on co-pilot's side. The oil reservoir is contained in the pilot's brake pumps.

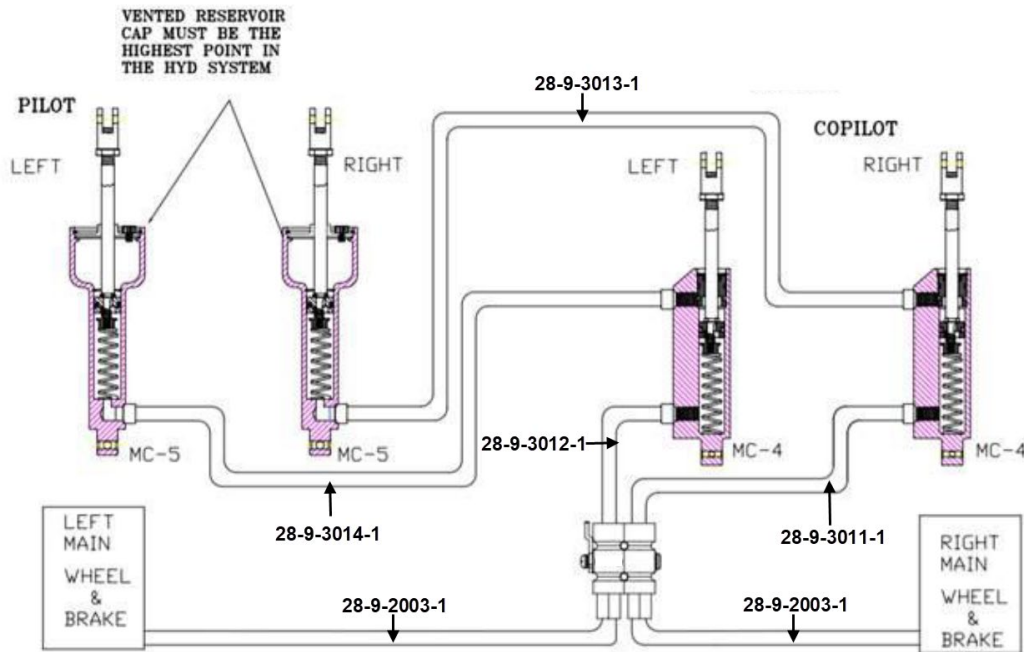

FIG. 7-10. BRAKE SYSTEM SCHEMATIC (MOD2008/124)

INTENTIONALLY LEFT BLANK

SECTION 8 – GROUND HANDLING & SERVICE**INDEX**

1. INTRODUCTION	2
2. AIRCRAFT INSPECTION INTERVALS.....	3
3. AIRCRAFT CHANGES OR REPAIRS.....	4
4. MAINTENANCE	5
4.1 REFUELING	5
4.2 OIL LEVEL CONTROL	5
4.3 LANDING GEAR TIRES PRESSURE CONTROL.....	5
5. ENGINE COWLING CHECK.....	6
5.1 UPPER COWLING	6
5.2 LOWER COWLING	6
6. GROUND HANDLING	7
6.1 TOWING.....	7
6.2 PARKING AND TIE-DOWN.....	7
6.3 MOORING.....	8
6.4 JACKING.....	8
6.5 ROAD TRANSPORT	8
7. CLEANING AND CARE.....	9
7.1 WINDOWS	9
7.2 EXTERNAL SURFACES	9
7.3 PROPELLER.....	9
7.4 ENGINE	9
7.5 INTERNAL SURFACES	9
8. ICE REMOVAL	10

1. INTRODUCTION

This section contains factory-recommended procedures for proper ground handling and routine care and servicing. It also identifies certain inspection and maintenance requirements.

It is recommended to follow a planned schedule of lubrication and preventive maintenance based on climatic and flying conditions encountered locally.

2. AIRCRAFT INSPECTION INTERVALS

Scheduled inspections must be performed in accordance with the instructions addressed on the Aircraft Maintenance Manual. Independently from the aircraft flight hours, an annual inspection has to be performed.

All required inspections are reported in the Aircraft Maintenance Manual.

As far as the scheduled/unscheduled engine maintenance is concerned, refer to the engine manufacturer Maintenance Manual.



Unscheduled inspections/maintenance tasks are necessary when one or more of following conditions occur:

- 1. Emergency landing*
- 2. Breaking / damage of propeller (or in case of simple impact)*
- 3. Engine fire*
- 4. Lighting damage*
- 5. Any type of damage or failure*

3. AIRCRAFT CHANGES OR REPAIRS

Aircraft changes or repairs must be performed in accordance with Aircraft Maintenance Manual and Job cards provided by TECNAM.

4. MAINTENANCE

4.1 REFUELING



WARNING

- *Do not perform aircraft refuelling near flames, sparks or similar.*
- *Avoid fuel contact with the skin: a skin corrosion could occur.*
- *Make sure that a fire extinguisher is available nearby during refuelling operations.*
- *Make sure that overall aircraft instrumentation is turned OFF before performing the refuelling.*
- *Do not operate switches and/or pushbuttons inside the aircraft during refuelling operation; make sure that crew left the aircraft before performing refuelling.*
- *Make sure that the aircraft is electrically connected to the ground.*

4.2 OIL LEVEL CONTROL

1. Open the engine cowling (RH)
2. Prior to oil check, switch off ignition circuit and turn the propeller by hand in direction of engine rotation several times to pump oil from the engine into the oil tank, or let the engine idle for 1 minute. This process is finished when air is returning back to the oil tank and can be noticed by a murmur from the open oil tank.
3. Clean the dipstick and soak it in the reservoir
4. Remove dipstick and read oil level
5. If required, replenish oil: oil level should be between max. and min. Marks shown on the dipstick
6. Close the engine cowling

4.3 LANDING GEAR TIRES PRESSURE CONTROL

For each wheel proceed as follows:

1. Remove wheel fairing
2. Unscrew the tire cap
3. Connect a gauge
4. Read the pressure value
5. If required, rectify the pressure (nose tire 2.2 Bar / 32 Psi, main landing gear tires 2.8 Bar / 40 Psi)
6. Fit the tire cap
7. Install wheel fairing

5. ENGINE COWLING CHECK

5.1 UPPER COWLING

- I. Parking brake: *ON*
- II. Fuel selector valve: *OFF*
- III. Magnetos: *OFF*
- IV. Generator & Master switches: *OFF*
- V. Unlatch all four butterfly Cam-locks mounted on the cowling by rotating them 90° counter clockwise while slightly pushing inwards.
- VI. Remove engine cowling paying attention to propeller shaft passing through nose.
- VII. To assemble: rest cowling horizontal insuring proper fitting of nose base reference pins.
- VIII. Secure latches by applying light pressure, check for proper assembly and fasten Cam-locks.



Butterfly Cam-locks are locked when tabs are horizontal and open when tabs are vertical. Verify tab is below latch upon closing.

WARNING

5.2 LOWER COWLING

- I. After disassembling upper cowling, move the propeller to a horizontal position.
- II. Using a standard screwdriver, press and rotate 90° the two Cam-locks positioned on lower cowling by the firewall.
- III. Disconnect the ram-air duct from the NACA intake. Pull out the first hinge pin positioned on the side of the firewall, then, while holding cowling, pull out second hinge pin; remove cowling with downward motion.
- IV. For installation follow reverse procedure.

6. GROUND HANDLING

6.1 TOWING

The aircraft is most easily and safely maneuvered by hand by pushing on wing struts near attachments or by pulling it by its propeller near the axle. A tow bar can be fixed onto nose gear fork. To obtain a minimum radius turn, the aircraft may be rotated around either main landing gear by pressing lightly down on a tail cone just forward of the horizontal stabilizer to raise the nose wheel off the ground.

6.2 PARKING AND TIE-DOWN

General

Under normal weather conditions, the airplane may be parked and headed in a direction that will facilitate servicing without regard to prevailing winds. Ensure that it is sufficiently protected against adverse weather conditions and present no danger to other aircraft.

Procedure

1. Position airplane on levelled surface, headed into the prevailing wind, if practical.
2. Engage parking brake
3. Secure pilot control stick by wrapping the seat belt around it

NOTE:

Do not engage the parking brakes at low ambient temperature, when an accumulation of moisture may cause the brakes to freeze, or when they become hot from severe use. In this case use wheel chocks.

In case of long time parking or overnight parking, it is recommended to moor the a/c as shown on Para.6.3.



CAUTION

Moorings is strongly recommended when the wind is more than 15 knots and the a/c is completely refuelled.

6.3 MOORING

The aircraft is moored to insure its immovability, protection, and security under various weather conditions.



CAUTION

Mooring is strongly recommended when the wind is more than 15 knots and the a/c is completely refuelled.

Procedure

1. Position airplane on levelled surface and headed into the prevailing wind, if practical
2. Centre nose wheel and engage parking brake and/or use the wheel chocks

NOTE:

Do not engage the parking brakes at low ambient temperature, when an accumulation of moisture may cause the brakes to freeze, or when they become hot from severe use. In these cases use wheel chocks.

3. Secure pilot control stick by wrapping the seat belt around it
4. Assure that flaps are retracted
5. Electrically ground airplane, by connecting ground cable to the engine muffle
6. Install control locks
7. Install protective plugs
8. Close and lock cabin doors.
9. Secure tie-down cables to the nose gear leg (and to the wings (in correspondence of wing struts) and tail cone tie-down rings at approximately 45 degree with respect to the ground.

NOTE:

Additional preparation for high winds includes tie-down ropes from the main landing gear employment.

6.4 JACKING

The aircraft can be lifted up by hydraulic jacks in correspondence of the points shown by external placards.

For the correct procedure please refer to the Maintenance Manual.

6.5 ROAD TRANSPORT

It is recommended to secure tightly all aircraft components onto the cart to avoid damage during transport. Minimum cart size is 7x2.5 meters. It is suggested to place wings under the aircraft's bottom, secured by specific clamps. Secondary components like the stabilator shall be protected from accidental hits using plastic or other material. For correct rigging and de-rigging procedure, refer to the Maintenance Manual.

7. CLEANING AND CARE



Aircraft surface must be kept clean to ensure expected flight performance. Excessively dirty surfaces can affect normal flight conditions.

7.1 WINDOWS

For windows cleaning, it is allowed the use of acrylic products employed for glass and Plexiglas surfaces cleaning.

7.2 EXTERNAL SURFACES

Aircraft surface is cleaned with soapy water; they are not allowed solvents or alcohol based products. Died insects must be removed using hot water.

It is advisable to avoid outside aircraft parking for long periods; it is always convenient to keep the aircraft in the hangar.

7.3 PROPELLER

To preserve its functionality avoiding wear and corrosion, the propeller manufacturer uses, for external surface painting, an acrylic paint which is resistant to all solvents. In any case it is advisable to clean the propeller using exclusively soapy water.

7.4 ENGINE

Engine cleaning is part of the scheduled maintenance. Refer to the engine manufacturer Maintenance Manual for operating and for planning its cleaning.

7.5 INTERNAL SURFACES

Interiors must be cleaned with a rate of 3 to 6 months. Any object present in the cabin (like pens, lost property, maps etc) must be removed.

The instrumentation as a whole must be cleaned with a humid cloth; plastic surfaces can be cleaned with suitable products.

For parts not easily accessible, perform cleaning with a small brush; seats must be cleaned with a humid cloth.

8. ICE REMOVAL

Anti icing products are not allowed. To remove ice, tow the aircraft in the hangar and operate with a soft brush or a humid cloth.

SECTION 9 – AFM Supplements

INDEX

1. INTRODUCTION	2
2. SUPPLEMENTS LIST	3

1. INTRODUCTION

This Section concerns the supplemental manuals of additional (or optional) instrumentation equipping the *P2008JC* and/or information and limitations related to installed equipment configuration or needed to fit local national rules.

2. SUPPLEMENTS LIST

Aircraft S/N:		Registration marks:		Date:	
Sup. No.	Title	Rev. no.	Date	APPLICABLE:	
				YES	NO
S1	VFR Night equipment configuration	6		<input type="checkbox"/>	<input type="checkbox"/>
S2	AveoMaxx Hercules Landing/Taxi lights	2		<input type="checkbox"/>	<input type="checkbox"/>
S3	Hoffman propeller	3		<input type="checkbox"/>	<input type="checkbox"/>
S4	MTOW increment at 650 kg	3		<input type="checkbox"/>	<input type="checkbox"/>
S5	Argentine AFMS	0		<input type="checkbox"/>	<input type="checkbox"/>
S6	Aircraft Flight Manual Supplement for MOGAS MG95 IS 2796:2017	2		<input type="checkbox"/>	<input type="checkbox"/>
S7	MTOW increment at 650 kg for airplane equipped with Hoffmann propeller	6		<input type="checkbox"/>	<input type="checkbox"/>
S8	MD302 and G3X Touch	7		<input type="checkbox"/>	<input type="checkbox"/>
S9	MTV 34 Propeller for aircraft with MTOW Increment at 650 kg	4		<input type="checkbox"/>	<input type="checkbox"/>
S10	GARMIN GTX 3X5 Transponder	3		<input type="checkbox"/>	<input type="checkbox"/>
S11	KR87 ADF System	1		<input type="checkbox"/>	<input type="checkbox"/>
S12	GARMIN GTR 225A/B / 205	3		<input type="checkbox"/>	<input type="checkbox"/>
S13	AFM Supplement for China	1		<input type="checkbox"/>	<input type="checkbox"/>
S14	Garmin G3X Touch (VFR Day)	5		<input type="checkbox"/>	<input type="checkbox"/>

INTENTIONALLY LEFT BLANK

SUPPLEMENT NO.S1 VFR NIGHT EQUIPMENT CONFIGURATION

Record of Revisions

Rev	Revised page	Description of Revision	Tecnam Approval			EASA Approval or UnderDOA Privileges	
			DO	OoA	HDO		
0	All	Editorial revision	A. Sabino	C. Caruso	M. Oliva	DOA Approval	
1	Cover pages	Rearranged	A. Sabino	C. Caruso	M. Oliva	Approved under the authority of DOA, ref. EASA.21J.335 (MOD2008/103.180312)	
	2N-1 thru 18, 23, 24, 27, 29, 30	Pages removed, information already contained in basic AFM					
	3N-2, 3, 4, 8, 9, 12 thru 21, 23, 24						
	7N-2, 3, 4, 5, 9, 10, 11, 12, 17, 18						
	3N-1						Index of Section 3 amended
	3N-6, 7, 22						Content rearranged
	4N-3, 4						Information added to normal operations speeds table; paragraph shifted from page 3 to page 4.
	4N-11 thru 18	Checklist amended					
2	S1-1	LOEP correction	A. Sabino	D. Ronca	M. Oliva	Approved under the authority of DOA, ref. EASA.21J.335 (MOD2008/113.190404)	
3	S1-4 2N-25 3N-22	Oil brakes placard update Choke and Alternate static port placard update Procedure optimization	G. Valentino	D. Ronca	M. Oliva	Approved under the authority of DOA, ref. EASA.21J.335 (MOD2008/143.200730)	
4	S1-1 S1-1, 4 2N-27	Cover and LOEP updated Typo errors correction	L. De Salvi	D. Ronca	M. Oliva	Approved under the authority of DOA, ref. EASA.21J.335 (MOD2008/188.230126)	
5	S1-1, 4 2N-27	Cover and LoEP Updates Typo errors corrections	F. Paloni	D. Ronca	M. Oliva	Approved under the authority of DOA, ref. EASA.21J.335 (MOD2008/199.230605)	
6	S1-1 2N-27	Cover and LoEP Updates Optimization	F. Losappio	D. Ronca	M. Oliva	Approved under the authority of DOA, ref. EASA.21J.335 (MOD2008/254.251014)	

List of Effective Pages

	Page	Revision
Cover Pages	S1-1	Rev 6
	S1-4	Rev 5
	S1-2 thru 3, 5 thru 10	Rev 1
Section 2	2N-19 thru 22, 26 thru 28	Rev 0
	2N-25	Rev 3
	2N-27	Rev 6
Section 3	3N-5, 10, 11	Rev 0
	3N-1, 6, 7	Rev 1
	3N-22	Rev 3
Section 4	4N-3	Rev 1
Section 7	7N-1, 6 thru 8, 13	Rev 1

INTRODUCTION

The information contained herein supplements or supersedes the basic Aircraft Flight Manual: detailed instructions are provided to allow the owner for replacing the basic AFM pages containing information amended as per the VFR Night Equipment Configuration in subject.

It is the owner's responsibility to replace the mentioned pages in accordance with the instructions herein addressed section by section.

Supplement S1: pages replacement instructions

SECTION 1 –GENERAL

Refer to Basic AFM Section 1.

Supplement S1: pages replacement instructions
--

SECTION 2 – LIMITATIONS

Follow replacing instructions contained in the table below.

Supplement pages		AFM Pages
2N-19 thru 22	REPLACE	Page 2-19 thru 22 of basic AFM
2N-25 thru 28	REPLACE	Page 2-25 thru 28 of basic AFM

20. KINDS OF OPERATION EQUIPMENT LIST (KOEL)

This paragraph reports the KOEL table, concerning the equipment list required on board under CS-VLA regulations to allow flight operations in VFR Day and VFR Night.

Flight in VFR Day and Night is permitted only if the prescribed equipment is installed and operational.



VFR NIGHT operation is limited to airfields providing centre line illumination.

Additional equipment, or a different equipment list, for the intended operation may be required by national operational requirements and also depends on the airspace classification and route to be flown. The owner is responsible for fulfilling these requirements.



Primary flight information (airspeed, altitude, heading and attitude) is provided by analogue instruments. All information provided by G3X is only intended for situational awareness.

Equipment	VFR Day	VFR Night
ANALOGUE ALTIMETER	•	•
ANALOGUE AIRSPEED INDICATOR	•	•
MAGNETIC DIRECTION INDICATOR	•	•
ANALOGUE ATTITUDE INDICATOR		•
ANALOGUE FUEL QUANTITY INDICATORS	•	•
ANALOGUE CHT INDICATOR	•	•
ANALOGUE RPM INDICATOR	•	•
ANALOGUE OIL TEMPERATURE INDICATOR	•	•
ANALOGUE VOLTMETER	•	•
GARMIN G3X SUITE		
TRANSPONDER	•	•
ALTITUDE ENCODER	•	•
SLIP INDICATOR	•	•
LONGITUDINAL TRIM INDICATOR	•	•
FLAP POSITION INDICATOR	•	•
COMM/NAV EQUIPMENT	•	•
AUDIO PANEL/MARKER BEACON	•	•
LANDING/TAXI LIGHT		•
STROBE LIGHTS		•
NAV LIGHTS		•
ANNUNCIATOR PANEL	•	•
BREAKERS PANEL	•	•
STALL WARNING SYSTEM	•	•
FIRST AID KIT	•	•
HAND-HELD FIRE EXTINGUISHER	•	•
ELT	•	•
PITOT HEAT		•
TORCH (WITH SPARE BATTERIES)		•
PANEL LIGHTS		•
EMERGENCY LIGHT		•
DIMMING DEVICES		•
DAY/NIGHT SWITCH		•

21. LIMITATIONS PLACARDS

The following limitation placards are placed in plain view on the pilot.

On the left side instrument panel, above on the left, it is placed the following placard reporting following speed limitation:

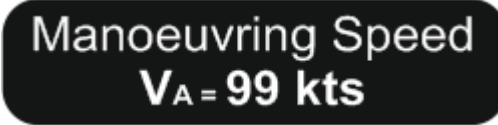

On the central side of the instrument panel, the following placard is placed reminding the observance of aircraft operating limitations according to the installed equipment configuration (see KOEL, Para. 20):



On the right hand side of the instrument panel the following placard is placed reminding the observance for “no smoking”:



In the baggage compartment following placard is placed:

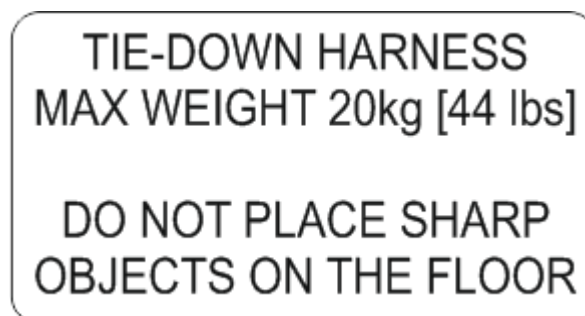

Below the G3X screens and analogue instruments, the following labels are placed:



Throttle marking

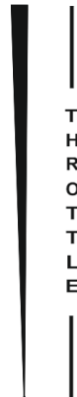

Fuel selector valve marking

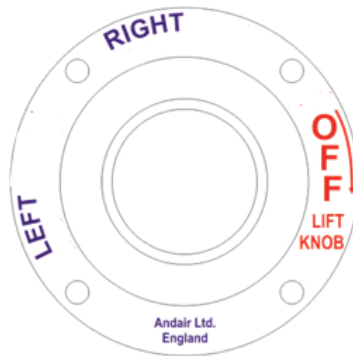

Choke placard



or (for aircraft with G3X Touch):



Alternate static port placard



Or (for aircraft with G3X Touch):



Cabin heat/defrost placard



Carb heat placard



Ignition key placard



Master/Generator placards



Map-light placard



MAP - LIGHT

Flap indicator placard

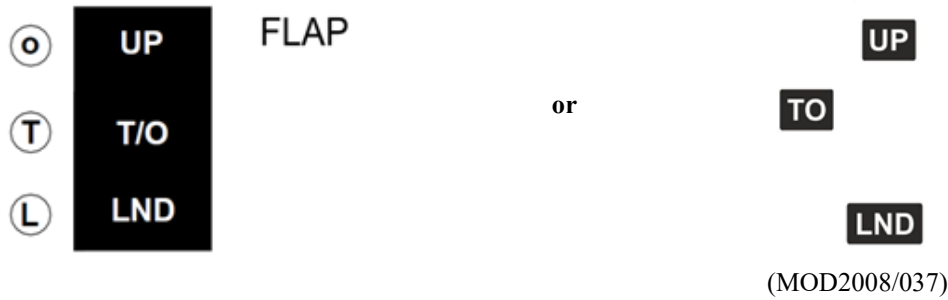

Backrest lever placard

**BACKREST: PRESS
TO UNLOCK**

Safety equipment location placard

**FIRST AID KIT
FIRE EXTINGUISHER
are in the luggage
compartment**

Elt placard



Battery placard

**BATTERY INSIDE
BEHIND
THIS PANEL**

Annunciator panel

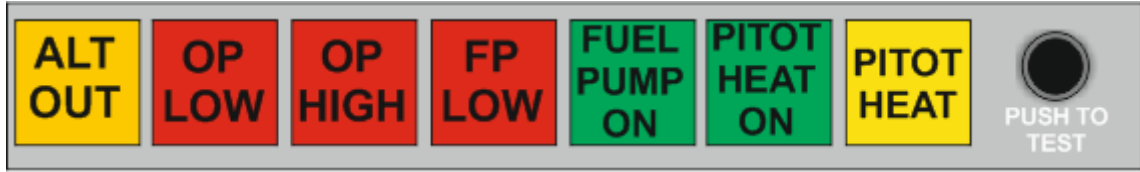

Upper panel labels



Switches labels



Day/Night switch label

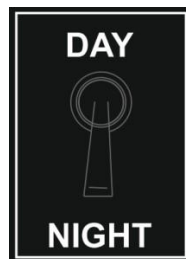

Door lock lever

CLOSED

OPEN

Supplement S1: pages replacement instructions

SECTION 3 – EMERGENCY PROCEDURES

Follow replacing instructions contained in the table below.

Supplement pages		AFM Pages
3N-1	REPLACES	Page 3-1 of basic AFM
3N-5 thru 7	REPLACE	Page 3-5 thru 7 of basic AFM
3N-10	REPLACES	Page 3-10 of basic AFM
3N-11	REPLACES	Page 3-11 of basic AFM
3N-22	REPLACES	Page 3-22 of basic AFM

SECTION 3 – EMERGENCY PROCEDURES

INDEX

1. INTRODUCTION	3
2. AIRPLANE ALERTS	4
2.1. Electric Power System Malfunction.....	5
2.2. G3X Failures	6
2.3. Pitot Heating System Failure	7
3. AIRPLANE EVACUATION	8
4. ENGINE SECURING.....	8
5. ENGINE FAILURE.....	9
5.1. Engine Failure During Take-Off Run.....	9
5.2. Engine Failure Immediately After Take-off.....	9
5.3. Engine Failures During Flight.....	10
5.3.1 Low Fuel Pressure	10
5.3.2 Low Oil Pressure	11
5.3.3 High Oil Temperature	12
5.3.4 CHT/CT limit exceedance	13
6. IN-FLIGHT ENGINE RESTART	14
7. SMOKE AND FIRE	15
7.1. Engine fire on the ground.....	15
7.2. Engine Fire During Takeoff	15
7.3. Engine Fire In-Flight	16
7.4. Cabin Fire / Electrical smoke in cabin during flight	16
7.5. Electrical smoke/fire in cabin on the ground.....	16
8. LANDING EMERGENCIES	17
8.1. Forced Landing Without Engine Power.....	17
8.2. Power-On Forced Landing	17
8.3. Landing With A Flat Nose Tire	17
8.4. Landing With A Flat Main Tire.....	18
9. RECOVERY FROM UNINTENTIONAL SPIN.....	19
10. OTHER EMERGENCIES	20
10.1. Unintentional Flight Into Icing Conditions	20
10.2. Trim System Failure	21
10.3. Flaps Failure	21
10.4. Static ports failure	22

2.1. ELECTRIC POWER SYSTEM MALFUNCTION

Alternator Failure Light ON

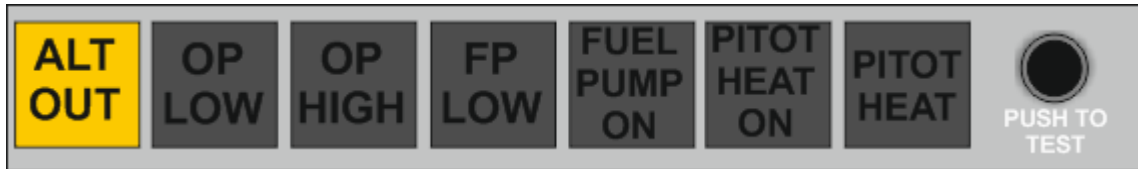

NOTE

Alternator light may illuminate for a faulty alternator or when voltage is above 16V; in this case the over-voltage sensor automatically shuts down the alternator.

If **ALTOUT** caution is **ON**:

1. Verify failure
2. Circuit breaker(s) *Check*
3. Generator switch: *OFF 1 sec. then back ON*

If ALTOUT caution persists ON:

4. Generator switch: *OFF*
5. *Reduce electrical load as much as possible*

6. **Land as soon as practical.**

NOTE

The battery can supply electrical power for at least 30 minutes.

2.2 G3X FAILURES

In case of LH or RH display failure, navigation and engine data will be automatically available in the remaining display(split mode).



INSTRUCTION: revert to the remaining display.

2.3 PITOT HEATING SYSTEM FAILURE

When the Pitot Heat system is activated, the green **PITOT HEAT ON** safe operating annunciation is **ON**;

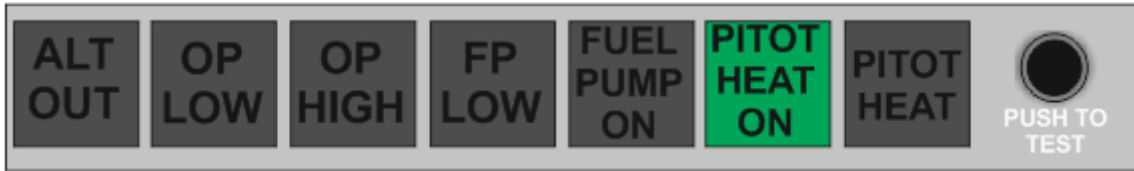

If the amber **PITOT HEAT** is turned ON, but the caution remains ON, the Pitot Heat system is not functioning properly.

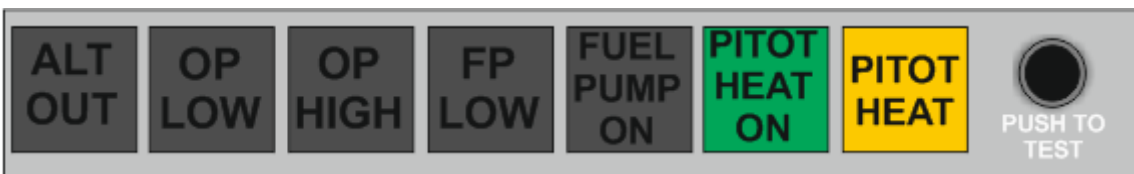

In this case apply following procedure:

1. Pitot Heat switch *OFF*
2. Check Pitot Heat circuit breaker *IN*
3. Pitot Heat switch *ON*
4. Check PITOT HEAT caution light:
 If the amber light stays ON, assume PITOT HEAT malfunction.
 Avoid visible moisture conditions.

5.3 ENGINE FAILURES DURING FLIGHT

5.3.1 Low Fuel Pressure



If the fuel pressure indicator falls below 2.2 psi / **FP LOW** warning is **ON**:

1. Electric fuel pump: *ON*
2. Fuel selector valve: *select opposite fuel tank if NOT empty*
3. Fuel quantity indicators: *Check both*

If fuel pressure does not build up:

4. **Land as soon as possible** applying forced landing procedure (See Para. 8)

5.3.2 Low Oil Pressure

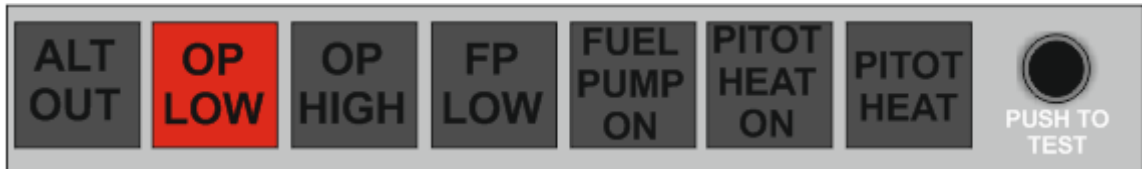

If oil pressure is below 12 psi / **OP LOW** warning is ON:

1. Throttle Lever *REDUCE to Minimum practical*
2. **Land as soon as practical**

If oil pressure does not increase and **OP LOW** warning persists ON:

3. **Land as soon as possible** applying forced landing procedure (See Para. 8)

10.3 STATIC PORTS FAILURE

In case of static ports failure, the alternate static port in the cabin must be activated.

In this case apply following procedure:

1. Cabin heat *OFF*
2. ALTERNATE STATIC PORT VALVE *OPEN*
3. Continue the mission

Supplement S1: pages replacement instructions

SECTION 4 – NORMAL PROCEDURES

Follow replacing instructions contained in the table below.

Supplement S1 pages		Basic AFM Pages
4N-3	REPLACES	4-3

1. INTRODUCTION

Section 4 describes checklists and recommended procedures for the conduct of normal operations for P2008 JC aircraft.



Garmin G3X is NOT intended to be used as primary reference for flight information but only provides information for situational awareness.

Primary flight information is provided by analogue instruments and, for engine parameters, pilot will rely upon caution/warning lights in the annunciator panel.

Supplement S1: pages replacement instructions

SECTION 5 - PERFORMANCE

Refer to Basic AFM Section 5.

Supplement S1: pages replacement instructions

SECTION 6 – WEIGHT AND BALANCE

Refer to Basic AFM Section 6.

Supplement S1: pages replacement instructions

SECTION 7 – AIRFRAME AND SYSTEM DESCRIPTION

Follow replacing instructions contained in the table below.

Supplement S1 pages		Basic AFM Pages
7N-1	REPLACES	7-1
7N-6	REPLACES	7-6
7N-7	REPLACES	7-7
7N-8	REPLACES	7-8
7N-13	REPLACES	7-13

SECTION 7 – AIRFRAME AND SYSTEMS DESCRIPTION

INDEX

1.	INTRODUCTION	2
2.	AIRFRAME.....	2
2.1.	Wing.....	2
2.2.	Fuselage	3
2.3.	Empennages	3
2.4.	Landing gear.....	4
3.	FLIGHT CONTROLS	5
4.	INSTRUMENT PANEL	6
4.1.	Carburettor Heat	7
4.2.	Cabin Heat.....	7
4.3.	Internal Lights System	8
5.	SEATS AND SAFETY HARNESS.....	9
6.	DOORS.....	9
7.	POWERPLANT	10
7.1.	ENGINE	10
7.2.	PROPELLER	10
8.	FUEL SYSTEM.....	11
9.	ELECTRICAL SYSTEM	12
9.1.	Stall Warning System	12
9.2.	Avionics	13
9.3.	External Power Supply	14
10.	PITOT-STATIC PRESSURE SYSTEMS	15
11.	BRAKES.....	16

4. INSTRUMENT PANEL

The instrument panel is divided in four areas:

- The left area holds primary (analogue) and pilot's situational awareness (G3X LH display) flight instruments, a chronometer and the pitch trim indicator;
- The right area holds engine and moving map indicator (G3X RH display), an analogue backup CHT indicator and breaker panel;

NOTE

Analogue CHT is a backup for the information provided by G3X. Since the pick-up location for the sensors is different (cylinder 2 and 4 respectively), analogue CHT could indicate a temperature up to 20° less than the G3X.

- The central area holds Nav/Com instrument, the transponder, warning lights, trim cut out switch and Trim LH/RH selector switch and the annunciator panel with following lights:
 - Electric fuel pump ON (GREEN)
 - Low Oil Pressure (RED)
 - Low Fuel Pressure (RED)
 - Alternator Fail (AMBER)
 - Pitot heat operation lights (GREEN/AMBER) - optional
- The lower-LH portion of the instrument panel holds:
 - Ignition key;
 - Master and Generator switches;
 - Emergency fuel pump;
 - Avionic Master switch;
 - Pitot heat switch (optionally provided);
 - Carburetor heat knob;
- The lower-Central portion of the instrument panel holds:
 - Throttle;
 - Two analogue fuel quantity indicators;
 - Fuel selector valve.
- The lower-RH portion of the instrument panel holds:
 - Flap indicator and control;
 - Cabin heating knob;
 - NAV, land and strobe switches.

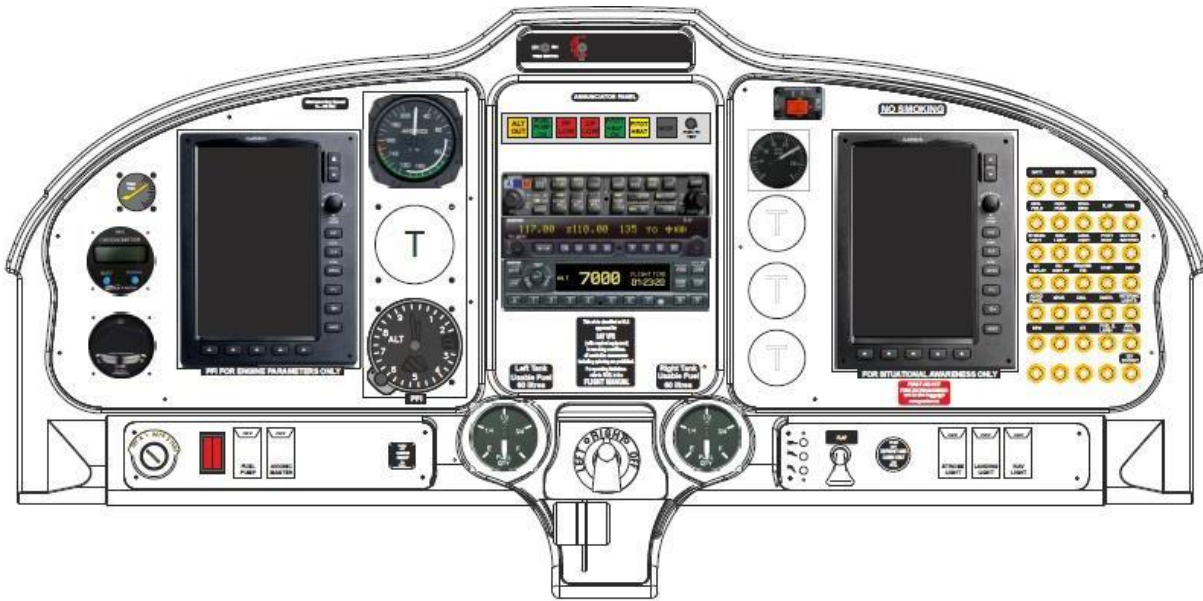

Fig. 7-5. INSTRUMENT PANEL

4.1. CARBURETTOR HEAT

Carburettor heat control knob is located lower-LH portion of the instrument panel; when the knob is pulled fully outward from the instrument panel, carburetors receive maximum hot air. During normal operation, the knob is set in OFF position.

4.2. CABIN HEAT

The cabin heat control knob is positioned on the lower right side of the instrument panel; when knob is pulled fully outward, cabin receives maximum hot air. If the outlets are kept closed, hot air only performs windshield defrost. Vents are located by the rudder pedals. If necessary, outside fresh air can be circulated inside cabin by opening the vents on the doors' windows.

4.3. INTERNAL LIGHTS SYSTEM

An internal lightning system is provided; it's based on the following elements:

- 2 dimmable panel lights (with flexible and adjustable supports) located in both sides of the dashboard and 2 LED lights above the annunciator panel (Panel DIM device);
- 2 emergency lights located in side area of the cabin ceiling and 1 LED light above the annunciator panel (all controlled by red Emergency Switch);
- 1 adjustable map-light located in the center area of the cabin ceiling.



Fig. 7-6 PANEL LIGHTS

9.2 AVIONICS

The avionic system installed P2008 JC features four analogue indicators, an airspeed indicator, an altimeter, a magnetic compass and a slip indicator, which provide primary flight information.

Garmin G3X integrated avionic suite in a dual screen configuration is installed. It provides flight information intended for the pilot's situational awareness only. The suite provides primary engine information, except fuel quantity information which is provided by two dedicated analogue indicators located in the bottom central instruments panel, supplemented by an annunciator panel and analogue CHT indicator. G3X also embodies a GPS WAAS receiver whose information, intended for situational awareness only, are presented on RH display moving map.

Two dedicated indicators provide the pilot with information about the flaps and pitch trim position.

Stand-alone external COM/NAV and transponder sources (Garmin SL 30 and GTX 328) are installed. Garmin SL 30 Navigation information is presented on the display (course and direction) along with the information related to active/standby frequency. This information is supplemented by an HSI indicator on G3X LH display.

GTX 328 transponder provides SSR (Secondary Surveillance Radar) responses; this unit is capable of both mode "S" and mode "C". An external altitude encoder (ACK A-30) allows altitude reporting, this information is also presented on GTX 328 display.

An automatic reversion mode is integrated within the system in order to continue providing the pilot with the flight and engine information in the event of a LH or RH display failure.

Four warning lights located on the top centre area of the instrument panel are available:

- Electric fuel pump ON (GREEN)
- Low Oil Pressure (RED)
- Low Fuel Pressure (RED)
- Alternator Fail (AMBER)

Two additional annunciator lights are installed when pitot heat system is optionally provided:

- Pitot heat ON (GREEN)
- Pitot heat fail (AMBER)

Supplement S1: pages replacement instructions

SECTION 8 – GROUND HANDLING & SERVICE

Refer to Basic AFM section 8.

SUPPLEMENT NO. S2
AVEOMAXX HERCULES LANDING/TAXI LIGHT INSTALLATION

Record of Revisions

Rev	Revised page	Description of Revision	Tecnam Approval			EASA Approval or Under DOA Privileges
			DO	OoA	HDO	
0	All	Editorial revision.	A. Sabino	C. Caruso	M. Oliva	Approved under the authority of DOA, ref EASA.21J.335
1	All cover pages	Amended.	A. Sabino	C. Caruso	M. Oliva	Approved under the authority of DOA, ref. EASA.21J.335 (MOD2008/103.180312)
	7AN-7	Paragraphs shifted.				
	Section 2 and Section 4 pages	Information integrated in basic AFM.				
2	S2-1, 7AN-6	MOD2008/239	F. Losappio	D. Ronca	M. Oliva	Approved under the authority of DOA, ref. EASA.21J.335 (MOD2008/239.250630)

List of Effective Pages

	Page	Revision
Cover Pages	S2-1	<i>Rev 2</i>
	S2-2 thru 4	<i>Rev 1</i>
Section 7	7AN-6	<i>Rev 2</i>
	7AN-7	<i>Rev 1</i>

INTRODUCTION

The information contained herein supplements or supersedes the basic Aircraft Flight Manual embodying Supplement S1: detailed instructions are provided to allow the owner for replacing the AFM pages, embodying Supplement S1, containing information amended as per AveoMaxx Hercules Landing/Taxi light installation in subject.

It is the owner's responsibility to replace the mentioned pages in accordance with the instructions herein addressed section by section.

Supplement S2: pages replacement instructions

SECTION 7 – AIRFRAME AND SYSTEM DESCRIPTION

**Make sure you first applied instructions reported on Supplement S1,
Section 7 Airframe and System description**

Apply following pages replacement procedure:

Supplement S2 – Section 7 page		Supplement S1 Section 7 page
7AN-6	REPLACES	N7-6
7AN-7	REPLACES	N7-7

INTENTIONALLY LEFT BLANK

4. INSTRUMENT PANEL

The instrument panel is divided in four areas:

- The left area holds primary (analogue) and pilot's situational awareness (G3X LH display) flight instruments, a chronometer, a pitch trim indicator and a holds Day/night switch (selecting between two brightness levels for warning lights in the annunciator panel);
- The right area holds thus a voltmeter, the breaker panel and primary analogue engine instruments:
 - Oil Temperature indicator
 - RPM indicator
 - CHT indicator
- The central area holds the stabilator trim cut out switch and LH/RH selector switch, the dimming devices (for G3X, for flexible support mounted panel lights and for instruments), Nav/Com instrument (Garmin GNC 255A or Garmin GNC 215), the GTX 328 transponder and the annunciator panel:
 - Electric fuel pump ON (GREEN)
 - Low Oil Pressure (RED)
 - Low Fuel Pressure (RED)
 - Alternator Fail (AMBER)
 - Pitot heat operation lights (GREEN/AMBER)
 - High Oil Pressure warning light (RED)
- The lower-LH portion of the instrument panel holds:
 - Ignition key;
 - Master and Generator switches;
 - Emergency fuel pump;
 - Avionic Master switch;
 - Pitot heat switch;
 - Emergency light switch;
 - Carburetor heat knob;
- The lower-Central portion of the instrument panel holds:
 - Throttle;
 - Two analogue fuel quantity indicators;
 - Fuel selector valve;
- The lower-RH portion of the instrument panel holds:
 - Flap indicator and toggle switch;
 - Cabin heating knob;
 - Landing, taxi, NAV and strobe switches.



Fig. 7-5. INSTRUMENT PANEL

4.1 CARBURETTOR HEAT

Carburettor heat control knob is located lower-LH portion of the instrument panel; when the knob is pulled fully outward from the instrument panel, carburettors receive maximum hot air. During normal operation, the knob is set in OFF position.

4.2 CABIN HEAT

The cabin heat control knob is positioned on the lower right side of the instrument panel; when knob is pulled fully outward, cabin receives maximum hot air. If the outlets are kept closed, hot air only performs windshield defrost. Vents are located by the rudder pedals. If necessary, outside fresh air can be circulated inside cabin by opening the vents on the doors' windows.

Supplement no. S3
AFMS for Hoffman propeller equipped airplanes

Record of Revisions

Rev	Revised page	Description of Revision	Tecnam Approval			EASA Approval or Under DOA Privileges
			DO	OoA	HDO	
0	New edition	Editorial revision	A. Sabino	C. Caruso	M. Oliva	Approved under the authority of DOA, ref EASA.21J.335
1	Cover pages	Rearranged	A. Sabino	C. Caruso	M. Oliva	Approved under the authority of DOA, ref. EASA.21J.335 (MOD2008/103.180312)
	H2-9	Note on oxygen use amended				
	H4-3, HN4-3	Information added to normal operations speeds table; paragraph shifted from page 3 to page 4.				
	H4-15, HN4-15	Pages removed, information included in basic AFM				
	H5-12 thru 13	Cruise performance amended				
	H6-10 thru 11	Pages removed, information included in basic AFM.				
	H7-8	Changed page number to match basic AFM				
	HN7-10	Page removed				
2	S3-1,6	Loop corrections	A. Sabino	D. Ronca	M. Oliva	Approved under the authority of DOA, ref. EASA.21J.335 (MOD2008/123.190620)
3	S3 - 1 S3 - 5 H4-4	Cover and LOEP updated Typo errors correction	L. De Salvi	D. Ronca	M. Oliva	Approved under the authority of DOA, ref. EASA.21J.335 (MOD2008/188.230126)

List of Effective Pages

	Page	Revision
Cover Pages	S3-1, 5	Rev 3
	S3-6	Rev 2
	S3-2,3,4,7,8	Rev 1
Section 1	H1-6	Rev 0
Section 2	H2-9	Rev 1
Section 4	H4-4	Rev 3
Section 5	H5-7 thru 11	Rev 0
	H5-12 thru 13	Rev 1
	H5-15 thru 16	Rev 0
Section 7	H7-10	Rev 1

INTRODUCTION

The information contained herein supplements or supersedes the basic Aircraft Flight Manual: detailed instructions are provided to allow the owner for replacing the AFM and Supplement S1 pages containing information amended as per Hoffman propeller in subject.

It is the owner's responsibility to replace the mentioned pages in accordance with the instructions herein addressed section by section.

Supplement S3: pages replacement instructions

SECTION 1 – GENERAL

**Make sure you first applied instructions reported on the basic AFM,
Section 1 General**

Apply following pages replacement:

Supplement S3 – GENERAL page		AFM Section 1 page
H1-6	REPLACES	Page 1-6 of AFM, Section 1

5 ENGINE

Manufacturer	Bombardier-Rotax GmbH
Model	912 S2
Engine type	4 cylinders horizontally opposed with 1352 c.c. of overall displacement, liquid cooled cylinder heads, ram-air cooled cylinders, two carburetors, integrated reduction gear box with torsional shock absorber and overload clutch.
Maximum power (at declared rpm)	73.5 kW (98.6hp) @ 5800 rpm (5 minutes maximum) 69.0 kW (92.5hp) @ 5500 rpm (continuous)

6 PROPELLER

Manufacturer	Hoffman Propeller
Model	HO17GHM A 174 177C
Blades	2 blades of Laminated hard wood. Composite structure, epoxy fibre glass cover
Diameter	1740 mm
Type	Fixed pitch

Supplement S3: pages replacement instructions

SECTION 2 – LIMITATIONS

Make sure you first applied instructions reported on the basic AFM and on the Supplement S1, Section 2 Limitations

Apply following pages replacement:

Supplement S3 – LIMITATIONS page		AFM Section 2 page	Supplement S1 Section 2 page
H2-9	REPLACES	Page 2-9	Page N2-9

9. PROPELLER

MANUFACTURER:	Hoffman Propeller
MODEL:	HO17GHM A 174 177C
BLADES:	2 blades of Laminated hard wood. Composite structure, epoxy fibre glass cover
TYPE:	Fixed pitch
DIAMETER:	1740 mm

10. MAXIMUM OPERATING ALTITUDE

Maximum operating altitude is 13000ft (3962 m) MSL.



CAUTION

Flight crew is recommended to use supplemental oxygen according to applicable Air Operations Rules.

11. AMBIENT TEMPERATURE

Ambient temperature: from -25°C to +50°C.



WARNING

Flight in expected and/or known icing conditions is forbidden.

Supplement S3: pages replacement instructions

SECTION 4 – NORMAL PROCEDURES

**Make sure you first applied instructions reported on the basic AFM,
Section 4 Normal Procedures**

Apply following pages replacement:

Supplement S3 – NORMAL PROCEDURES page		AFM Section 4 page
H4-4	REPLACES	Page 4-4 of AFM, Section 4

2. AIRSPEEDS FOR NORMAL OPERATIONS

The following airspeeds are those which are significant for normal operations.

	FLAPS	630kg
Rotation Speed (V_R)	T/O	48 KIAS
Flap Retraction Speed (V_{OBS})	T/O	58 KIAS
Best Angle-of-Climb Speed (V_X)	0°	63 KIAS
Best Rate-of-Climb speed (V_Y)	0°	67 KIAS
Approach speed	T/O	58 KIAS
Final Approach Speed	FULL	54 KIAS
Touch Down Speed	FULL	54 KIAS
Manoeuvring speed (V_A)	0°	99 KIAS
Never Exceed Speed (V_{NE})	0°	145 KIAS

Supplement S3: pages replacement instructions

SECTION 5 – PERFORMANCE

**Make sure you first applied instructions reported on the basic AFM,
Section 5 Performance**

Apply following pages replacement:

Supplement S3 – PERFORMANCE page		AFM Section 5 page
H5-7 thru 13	REPLACES	Page 5-7 thru 13 of AFM, Section 5
H5-15 and 16	REPLACES	Page 5-15 and 16 of AFM, Section 5

7. TAKE-OFF PERFORMANCE

NOTE

To account for likely in service performance variations apply a factored to distances of 1.10

Weight = 630 kg Flaps: T/O Speed at Lift-Off = 48 KIAS Speed Over 50ft Obstacle = 61 KIAS Throttle Levers: Full Forward Runway: Grass		Corrections Headwind: - 5m for each kt (16 ft/kt) Tailwind: + 15m for each kt (49 ft/kt) Paved Runway: - 10% to Ground Roll Runway slope: + 7% to Ground Roll for each +1%				
Pressure Altitude		Distance [m]				ISA
		Temperature [°C]				
[ft]		-25	0	25	50	
S.L.	Ground Roll	134	169	208	252	192
	At 50 ft AGL	283	352	431	518	398
1000	Ground Roll	146	184	227	275	206
	At 50 ft AGL	307	383	468	564	426
2000	Ground Roll	159	201	248	301	221
	At 50 ft AGL	334	417	509	613	456
3000	Ground Roll	174	219	271	328	237
	At 50 ft AGL	364	453	554	667	488
4000	Ground Roll	190	240	296	359	255
	At 50 ft AGL	396	493	603	726	523
5000	Ground Roll	208	262	323	392	274
	At 50 ft AGL	431	538	657	791	561
6000	Ground Roll	228	287	354	429	295
	At 50 ft AGL	470	586	717	862	602
7000	Ground Roll	249	314	388	470	317
	At 50 ft AGL	513	639	782	941	645
8000	Ground Roll	273	344	425	515	342
	At 50 ft AGL	560	698	853	1027	693
9000	Ground Roll	300	377	466	565	368
	At 50 ft AGL	611	762	932	1122	744
10000	Ground Roll	329	414	511	620	397
	At 50 ft AGL	668	833	1019	1226	800

Weight = 530 kg Flaps: T/O Speed at Lift-Off = 48 KIAS Speed Over 50ft Obstacle = 61 KIAS Throttle Levers: Full Forward Runway: Grass		Corrections Headwind: - 5m for each kt (16 ft/kt) Tailwind: + 15m for each kt (49 ft/kt) Paved Runway: - 10% to Ground Roll Runway slope: + 7% to Ground Roll for each +1%				
Pressure Altitude		Distance [m]				ISA
		Temperature [°C]				
[ft]		-25	0	25	50	
S.L.	Ground Roll	88	111	137	167	127
	At 50 ft AGL	190	237	290	349	268
1000	Ground Roll	96	121	150	182	136
	At 50 ft AGL	207	258	315	379	287
2000	Ground Roll	105	133	164	198	146
	At 50 ft AGL	225	280	342	412	307
3000	Ground Roll	115	145	179	217	157
	At 50 ft AGL	245	305	373	448	328
4000	Ground Roll	126	158	195	237	168
	At 50 ft AGL	266	332	406	488	352
5000	Ground Roll	137	173	214	259	181
	At 50 ft AGL	290	361	442	532	377
6000	Ground Roll	150	189	234	284	195
	At 50 ft AGL	316	394	482	580	404
7000	Ground Roll	165	207	256	311	210
	At 50 ft AGL	345	430	526	632	434
8000	Ground Roll	181	227	280	340	226
	At 50 ft AGL	376	469	574	690	466
9000	Ground Roll	198	249	308	373	243
	At 50 ft AGL	411	512	626	754	500
10000	Ground Roll	217	273	337	409	262
	At 50 ft AGL	449	560	685	824	537

Pressure Altitude		Distance [m]				
[ft]		Temperature [°C]				ISA
		-25	0	25	50	
S.L.	Ground Roll	54	67	83	101	77
	At 50 ft AGL	118	147	179	216	166
1000	Ground Roll	58	74	91	110	82
	At 50 ft AGL	128	159	195	234	177
2000	Ground Roll	64	80	99	120	88
	At 50 ft AGL	139	173	212	255	190
3000	Ground Roll	70	88	108	131	95
	At 50 ft AGL	151	189	231	277	203
4000	Ground Roll	76	96	118	143	102
	At 50 ft AGL	165	205	251	302	218
5000	Ground Roll	83	105	129	157	110
	At 50 ft AGL	180	224	273	329	233
6000	Ground Roll	91	115	142	172	118
	At 50 ft AGL	196	244	298	359	250
7000	Ground Roll	100	126	155	188	127
	At 50 ft AGL	213	266	325	391	268
8000	Ground Roll	109	138	170	206	137
	At 50 ft AGL	233	290	355	427	288
9000	Ground Roll	120	151	186	226	147
	At 50 ft AGL	254	317	388	466	309
10000	Ground Roll	131	166	204	248	159
	At 50 ft AGL	278	346	424	510	333

Weight = 430 kg
Flaps: T/O
Speed at Lift-Off = 48 KIAS
Speed Over 50ft Obstacle = 61 KIAS
Throttle Levers: Full Forward
Runway: Grass

Corrections
Headwind: - 5m for each kt (16 ft/kt)
Tailwind: + 15m for each kt (49 ft/kt)
Paved Runway: - 10% to Ground Roll
Runway slope: + 7% to Ground Roll for each +1%

8. TAKE-OFF RATE OF CLIMB

NOTE

To account for likely in service performance variations apply a factored to rate of climb of 0.90

Throttle Levers: Full Forward							
Flaps: Take Off (15°)							
Weight	Pressure Altitude	Climb Speed V _Y	Rate of Climb [ft/min]				ISA
			Temperature [°C]				
[kg]	[ft]	[KIAS]	-25	0	25	50	
630	S.L.	70	996	847	714	594	765
	2000	69	882	736	605	487	676
	4000	68	769	626	497	381	588
	6000	66	657	516	389	276	499
	8000	65	545	406	282	170	411
	10000	64	433	297	175	65	322
	12000	63	322	188	68	-39	233
	14000	62	211	79	-38	-144	145
580	S.L.	69	1118	961	820	694	875
	2000	68	999	844	706	581	781
	4000	67	879	727	592	469	688
	6000	66	761	611	478	358	594
	8000	65	642	495	364	246	500
	10000	64	524	380	251	135	407
	12000	63	406	265	139	25	313
	14000	62	289	150	27	-85	220
530	S.L.	69	1261	1093	943	808	1001
	2000	68	1133	968	821	688	901
	4000	67	1006	844	699	569	802
	6000	66	879	720	578	450	702
	8000	65	753	597	457	331	602
	10000	64	627	474	337	213	502
	12000	63	502	351	217	95	402
	14000	61	377	229	97	-22	303

9. EN-ROUTE RATE OF CLIMB

NOTE

To account for likely in service performance variations apply a factored to rate of climb of 0.90

Throttle Levers: Full Forward							
Flaps: UP							
Weight	Pressure Altitude	Climb Speed V _Y	Rate of Climb [ft/min]				ISA
			Temperature [°C]				
[kg]	[ft]	[KIAS]	-25	0	25	50	
630	S.L.	67	1028	878	745	624	796
	2000	67	914	767	636	517	707
	4000	67	801	656	527	410	618
	6000	67	688	545	418	304	529
	8000	67	575	435	311	198	440
	10000	67	463	325	203	92	351
	12000	67	351	216	96	-13	262
580	S.L.	67	1158	998	855	726	910
	2000	67	1036	879	739	612	815
	4000	67	915	761	623	498	720
	6000	67	794	643	507	385	625
	8000	66	674	525	392	272	530
	10000	66	554	408	277	159	435
	12000	66	435	291	162	47	340
530	S.L.	67	1308	1136	982	844	1042
	2000	67	1177	1008	857	721	940
	4000	66	1047	881	732	598	837
	6000	66	917	754	608	476	735
	8000	66	787	627	484	354	632
	10000	66	658	501	360	233	530
	12000	66	530	375	237	112	428
14000	65	401	250	114	-8	325	

10. CRUISE PERFORMANCE



Propeller speed over 2265 RPM is restricted to 5min.

Weight = 630 kg							
CORRECTIONS							
	KTAS	Fuel Consumption	Endurance	Range	Specific Range		
For each +15°C of OAT	-2%	-2.50%	2%	1%	1%		
For each -15°C of OAT	1%	3%	-4%	-2%	-1%		
For -100kg of weight	3.30%	-	-	3%	4%		
CRUISE PERFORMANCE							
Pressure	OAT	Propeller		Fuel	Endurance	Range	Specific Range
Altitude	ISA	RPM	KTAS	Consumption	[hr:mm]	[nm]	[nm/lt]
[ft]	[deg C]			[lt/hr]			
0	15	2388	119	26.9	4:28	531	4.4
		2250	111	24.6	4:53	542	4.5
		2100	102	20.7	5:48	591	4.9
		2000	96	18.7	6:25	616	5.1
		1900	90	17	7:04	635	5.3
		1800	84	15.6	7:42	646	5.4
2000	11	2250	110	23.5	5:06	562	4.7
		2100	101	19.9	6:02	609	5.1
		2000	95	18.1	6:38	630	5.3
		1900	89	16.6	7:14	643	5.4
		1800	83	15.3	7:51	651	5.4
4000	7	2250	109	22.4	5:21	584	4.9
		2100	101	19.2	6:15	631	5.3
		2000	95	17.5	6:51	651	5.4
		1900	89	16.2	7:24	659	5.5
		1800	83	15.1	7:57	660	5.5

Weight = 630 kg							
CORRECTIONS							
		KTAS	Fuel Consumption	Endurance	Range	Specific Range	
For each +15°C of OAT		-2%	-2.50%	2%	1%	1%	
For each -15°C of OAT		1%	3%	-4%	-2%	-1%	
For -100kg of weight		3.30%	-	-	3%	4%	
CRUISE PERFORMANCE							
6000	3	2250	109	21.3	5:38	614	5.1
		2100	100	18.5	6:29	649	5.4
		2000	94	17.1	7:01	660	5.5
		1900	88	15.9	7:33	664	5.5
		1800	82	14.9	8:03	660	5.5
8000	-1	2250	108	20.4	5:53	635	5.3
		2100	99	18	6:40	660	5.5
		2000	93	16.7	7:11	668	5.6
		1900	87	15.6	7:42	669	5.6
10000	-5	2250	107	19.7	6:05	652	5.4
		2100	98	17.5	6:51	672	5.6
		2000	92	16.4	7:19	673	5.6
		1900	86	15.4	7:48	670	5.6

12. BALKED LANDING PERFORMANCE

NOTE

To account for likely in service performance variations apply a factored to rate of climb and to angle of climb of 0.90

Throttle Levers: Full Forward						
Flaps: LAND						
Speed: 54 KIAS						
Weight [kg]	Pressure Altitude [ft]	Angle of Climb [deg]				
		Temperature [°C]				ISA
		-25	0	25	50	
630	S.L.	8.9	7.4	6.2	5	6.7
	2000	7.8	6.4	5.1	4	5.8
	4000	6.7	5.3	4.1	3	5
	6000	5.6	4.3	3	1.9	4.1
	8000	4.5	3.2	2	0.9	3.2
	10000	3.5	2.1	1	-0.1	2.4
	12000	2.4	1.1	-0.1	-1.1	1.5
	14000	1.3	0.1	-1.1	-2.1	0.7
530	S.L.	11.6	9.9	8.3	7	8.9
	2000	10.3	8.6	7.1	5.7	7.9
	4000	9	7.3	5.8	4.5	6.9
	6000	7.7	6.1	4.6	3.3	5.9
	8000	6.4	4.8	3.4	2.1	4.8
	10000	5.1	3.5	2.1	0.9	3.8
	12000	3.8	2.3	0.9	-0.3	2.8
	14000	2.5	1	-0.3	-1.6	1.8
430	S.L.	15.4	13.2	11.3	9.6	12.1
	2000	13.7	11.6	9.8	8.1	10.8
	4000	12.1	10.1	8.2	6.6	9.5
	6000	10.5	8.5	6.7	5	8.2
	8000	8.9	6.9	5.1	3.5	7
	10000	7.3	5.3	3.6	2	5.7
	12000	5.7	3.8	2.1	0.5	4.4
	14000	4.1	2.2	0.5	-1	3.2

13. NOISE DATA

Noise level, determined in accordance with ICAO/Annex 16 6th Ed., July 2011, Vol. I°, Chapter 10, is **68.06dB(A)**.

Supplement S3: pages replacement instructions

SECTION 6 – WEIGHT AND BALANCE

See basic AFM,
Section 6 Weight and Balance

Supplement S3: pages replacement instructions
--

SECTION 7 – AIRFRAME AND SYSTEMS DESCRIPTION

Make sure you first applied instructions reported on the basic AFM and on the Supplement S1,
Section 7 Airframe and Systems Description

Apply following pages replacement:

Supplement S3 – AIRFRAME AND SYSTEMS DESCRIPTION page		AFM
H7-10	REPLACES	Page 7-8 of Basic AFM or Page 7N-10 of Supplement S1

7. POWERPLANT

7.1. ENGINE

Manufacturer:	<i>Bombardier-Rotax GmbH</i>
Model:	<i>ROTAX 912 S2</i>
Type:	<i>4 stroke, horizontally-opposed 4 cylinder, mixed air and water cooled, twin electronic ignition, forced lubrication.</i>
Maximum rating:	<i>98.6hp (73.5kW) @ 5800 rpm/min (2388 rpm/min. prop). Gear reduction ratio - 2.4286:1</i>
Max oil consumption:	<i>Max: 0.1 litres/hour</i>

7.2. PROPELLER

Manufacturer:	<i>Hoffman Propellers</i>
Model:	<i>HO17GHM A 174 177C</i>
N° of blades:	<i>2</i>
Diameter:	<i>1740 mm</i>
Type:	<i>fixed pitch</i>

Supplement no. S4 MTOW Increment at 650 kg

Record of Revisions

Rev	Revised page	Description of Revision	Tecnam Approval			EASA Approval or Under DOA Privileges
			DO	OoA	HDO	
0	-	First Issue	A. Sabino	C. Caruso	M. Oliva	Approved under the authority of DOA, ref EASA.21J.335
1	S4-25	Blank page removed	A. Sabino	C. Caruso	M. Oliva	Approved under the authority of DOA, ref. EASA.21J.335 (MOD2008/103.180312)
	2W-6	Airspeed indicator markings amended; the indication is now proper for both analogue and digital instruments.				
	3WN-23	Page removed				
	3WN-21	Page number changed with 3N-21 to match basic AFM				
	4W-4	Information added to normal operations speeds table				
	4WN-3, 4W-15, 16, 4WN-15, 16, 4WAN-15, 4WAN-16	Pages removed, information integrated in basic AFM				
6W-9	W&B calculation sample revised					
2	S4-1 2W-21, 2WN-21 5W-16	Typo on placard location Typo on noise data	G.Valentino	D.Ronca	M.Oliva	Approved under the authority of DOA, ref. EASA.21J.335 (MOD2008/143.200730)
3	S4-1 4W-4	Typo on placard location Typo error correction	L. De Salvi	D.Ronca	M.Oliva	Approved under the authority of DOA, ref. EASA.21J.335 (MOD2008/188.230126)

List of Effective Pages

	Page	Revision
Cover Pages	S4-2 thru 7, 9, 10, 12, 13, 15 thru 24	Rev 0
	S4-8, 11, 14	Rev 1
	S4-1	Rev 3
Section 1	1W-7	Rev 0
Section 2	2W-5, 12, 16, 17	Rev 0
	2W-6	Rev 1
	2W-21, 2WN-21	Rev 2
Section 3	3W-9	Rev 0
	3W-21	Rev 1
Section 4	4W-4	Rev 3
Section 5	5W-1 thru 15	Rev 0
	5W-16	Rev 2
Section 6	6W-5, 6	Rev 0
	6W-9	Rev 1

INDEX

INTRODUCTION.....3
SECTION 1 – GENERAL.....5
SECTION 2 – LIMITATIONS8
SECTION 3 – EMERGENCY PROCEDURES11
SECTION 4 – NORMAL PROCEDURES14
SECTION 5 – PERFORMANCE17
SECTION 6 – WEIGHT AND BALANCE19
SECTION 7 – AIRFRAME AND SYSTEMS DESCRIPTION.....22
SECTION 8 – GROUND HANDLING & SERVICE.....24

INTRODUCTION

The information contained herein supplements or supersedes the basic Aircraft Flight Manual: detailed instructions are provided to allow the owner for replacing the AFM and Supplement S1 pages containing information amended as per Maximum Take-Off Weight Increment at 650 kg in subject.

It is the owner's responsibility to replace the mentioned pages in accordance with the instructions herein addressed section by section.

INTENTIONALLY LEFT BLANK

Supplement S4: pages replacement instructions

SECTION 1 – GENERAL

Make sure you first applied instructions reported on the basic AFM and on the Supplements (if applicable), Section 1 General

According A/C configuration apply following pages replacement:

Supplement S4 pages		Basic AFM pages
1W-7	REPLACES	Page 1-7

INTENTIONALLY LEFT BLANK

7. FLIGHT CONTROL SURFACES TRAVEL

Ailerons	Up 22° Down 14 ° (± 2°)
Stabilator (refer to Trailing Edge)	Up 4° Down 15° (± 2°)
Stabilator trim tab (refer to Trailing Edge)	Up 2°; Down 12° (± 1°)
Rudder	RH 25° LH 25° (± 2°)
Flaps	0°; 35° (± 1°)

8. SPECIFIC LOADINGS

	MTOW 650 kg (1433lb)
Wing Loading	53.5 kg/m ² (10.9 lb/sqft)
Power Loading	6.59 kg/hp (14.53 lb/hp)

INTENTIONALLY LEFT BLANK

Supplement S4: pages replacement instructions

SECTION 2 – LIMITATIONS

**Make sure you first applied instructions reported on the
basic AFM and on the Supplements (if applicable),
Section 2 Limitations**

According A/C configuration apply following pages replacement:

Supplement S4 pages		Basic AFM pages	Supplement S1 pages
2W-5	REPLACES	2-5	/
2W-6	REPLACES	2-6	/
2W-12	REPLACES	2-12	/
2W-16	REPLACES	2-16	/
2W-17	REPLACES	2-17	/
2W-21	REPLACES	2-21	/
2WN-21	REPLACES	/	2N-21

INTENTIONALLY LEFT BLANK

2. AIRSPEED LIMITATIONS

The following table addresses the airspeed limitations and their operational significance:

AIRSPEED		KIAS	KCAS	REMARKS
V _{NE}	Never exceed speed	143	139	Do not exceed this speed in any operation.
V _{NO}	Maximum Structural Cruising speed	111	110	Do not exceed this speed except in smooth air, and only with caution.
V _A	Design Manoeuvring speed	98	97	Do not make full or abrupt control movement above this speed, because under certain conditions the aircraft may be overstressed by full control movement.
V _O	Operating Manoeuvring speed			
V _{FE}	Maximum flaps extended speed	70	71	Do not exceed this speed for indicated flaps setting.

3. AIRSPEED INDICATOR MARKINGS

Airspeed indicator markings and their colour code are explained in the following table.

MARKING	KIAS	EXPLANATION
White arc/band	40 – 70	Positive Flap Operating Range (lower limit is V_{SO} , at specified maximum weight and upper limit is the maximum speed permissible with landing flaps extension).
Green arc/band	49 – 111	Normal Operating Range (lower limit is V_{S1} at specified maximum weight and most forward c.g. with flaps retracted and upper limit is maximum structural speed V_{NO}).
Yellow arc/band	111 – 143	Manoeuvres must be conducted with caution and only in smooth air.
Red line	143	Maximum speed for all operations.

14. WEIGHTS

Condition	Weight	
Maximum takeoff weight	650 kg	1433lb
Maximum landing weight	650 kg	1433lb

Baggage Compartment		
Maximum weight	20 kg	44lb
Maximum specific pressure	12,5 kg/dm ²	256 lbs/sq in

16. APPROVED MANOEUVRES

The aircraft is certified in Normal Category in accordance with EASA CS-VLA regulation applying to aeroplanes intended for non-aerobatic operation only.

Non aerobatic operation includes:

- Any manoeuvre pertaining to “normal” flight
- Stalls (except whip stalls)
- Lazy eights
- Chandelles
- Steep turns in which the angle of bank is not more than 60°

Recommended entry speeds for each approved manoeuvre are as follows:

Manoeuvre	Speed [KIAS]
Lazy eight	98
Chandelle	111
Steep turn (max 60°)	98
Stall	Slow deceleration (1 kts/s)



Acrobatic manoeuvres, including spins and turns with angle of bank of more than 60°, are not approved for such a category.



Limit load factor could be exceeded by moving abruptly flight controls at their end run at a speed above V_A (Manoeuvring Speed: 98 KIAS).



Flight in expected and/or known icing conditions, in proximity of storms or in severe turbulence is forbidden.

17. MANOEUVRES LOAD FACTOR LIMITS

Manoeuvre load factors limits are as follows:

Positive	Negative
+ 3.8 g	- 1.9 g

Manoeuvre load factors limits with flaps extended are as follows:

Positive	Negative
+ 1.9 g	0 g

21. LIMITATIONS PLACARDS

The following limitation placards are placed in plain view of the pilot.

Manoeuvring Speed
 $V_A = 98$ kts

This a/c is classified as VLA
approved for
DAY VFR
(with required equipment)
in non-icing conditions.
all aerobatics manoeuvres
including spinning are prohibited.
For operating limitations
refer to KOEL in the
FLIGHT MANUAL

On the right hand side of the instrument panel the following placard is placed reminding the observance for “no smoking”:

NO SMOKING

In the baggage compartment following placard is placed:

TIE-DOWN HARNESS
MAX WEIGHT 20kg [44 lbs]

DO NOT PLACE SHARP
OBJECTS ON THE FLOOR

21. LIMITATIONS PLACARDS

The following limitation placards are placed in plain view of the pilot.

Manoeuvring Speed
 $V_A = 98$ kts

This a/c is classified as VLA
approved for
DAY OR NIGHT VFR
(with required equipment)
in non-icing conditions.
all aerobatics manoeuvres
including spinning are prohibited.
For operating limitations
refer to KOEL in the
FLIGHT MANUAL

On the right hand side of the instrument panel the following placard is placed reminding the observance for “no smoking”:

NO SMOKING

In the baggage compartment following placard is placed:

TIE-DOWN HARNESS
MAX WEIGHT 20kg [44 lbs]

DO NOT PLACE SHARP
OBJECTS ON THE FLOOR

INTENTIONALLY LEFT BLANK

Supplement S4: pages replacement instructions

SECTION 3 – EMERGENCY PROCEDURES

Make sure you first applied instructions reported on the basic AFM and on the Supplements (if applicable),
Section 3 Emergency Procedures

According A/C configuration apply following pages replacement:

Supplement S4 pages		Basic AFM pages	Supplement S1 pages
3W-9	REPLACES	3-9	3N-9
3W-21	REPLACES	3-21	/

INTENTIONALLY LEFT BLANK

5. ENGINE FAILURE

5.1. ENGINE FAILURE DURING TAKE-OFF RUN

- | | |
|---------------------|------------------------------|
| 1. Throttle: | <i>IDLE (keep fully out)</i> |
| 2. Rudder: | <i>Keep heading control</i> |
| 3. Brakes: | <i>apply as needed</i> |

When safely stopped:

- | | |
|---------------------------------|-------------|
| 4. Ignition key: | <i>OFF.</i> |
| 5. Fuel selector valve: | <i>OFF</i> |
| 6. Electric fuel pump: | <i>OFF</i> |
| 7. Alternator& Master switches: | <i>OFF.</i> |

5.2. ENGINE FAILURE IMMEDIATELY AFTER TAKE-OFF

- | | |
|---|-----------------------------|
| 1. Speed: | <i>keep minimum 61 KIAS</i> |
| 2. Find a suitable place to land safely. | |



The immediate landing should be planned straight ahead with only small changes in directions not exceeding 45° to the left or 45° to the right.

- | | |
|------------------|------------------|
| 3. Flaps: | <i>as needed</i> |
|------------------|------------------|



Stall speed increases with bank angle and longitudinal load factor. Acoustic stall warning will in any case provides a correct anticipated cue of incipient stall.

At, or right before, touch down

- | | |
|--|----------------------------------|
| 4. Throttle: | <i>IDLE (fully out and hold)</i> |
| 5. Ignition key: | <i>OFF</i> |
| 6. Fuel selector valve: | <i>OFF</i> |
| 7. Electric fuel pump: | <i>OFF</i> |
| 8. Alternator& Master switches: | <i>OFF</i> |



A single engine aircraft take off should always be preceded by a thorough take off emergency pilot self-briefing. Decision to try an engine emergency restart right after take off should be taken only if environmental situation requires it: pilot shall never ignore the priority of attentively follow an immediate emergency landing.

After possible mechanical engine seizure, fire or a major propeller damage, engine restart attempt is not recommended.

10.2 TRIM SYSTEM FAILURE

Trim Jamming

Should trim control be inoperative, act as follows:

1. Breaker: *CHECK IN*
2. LH/RH Trim switch: *CHECK for correct position*

If jamming persists

1. Trim cutout switch: *CHECK ON*
2. Speed: *adjust to control aircraft without excessive stick force*
3. **Land aircraft as soon as possible.**

Trim Runaway

In event of trim runaway, act as follows:

1. Trim cutout switch: *OFF*
2. Speed: *adjust to control aircraft without excessive stick force*
3. **Land aircraft as soon as possible.**

10.3 FLAPS FAILURE

In event of flaps-up landing, account for:

- | | |
|-----------------|----------------------|
| Approach speed: | <i>65 KIAS</i> |
| Landing length: | <i>35% increased</i> |

INTENTIONALLY LEFT BLANK

Supplement S4: pages replacement instructions

SECTION 4 – NORMAL PROCEDURES

**Make sure you first applied instructions reported on the
basic AFM and on the Supplements (if applicable),
Section 4 Normal Procedures**

According A/C configuration apply following pages replacement:

Supplement S4 pages		Basic AFM pages
4W-4	REPLACES	4-4

INTENTIONALLY LEFT BLANK

2. AIRSPEEDS FOR NORMAL OPERATIONS

The following airspeeds are those which are significant for normal operations.

	FLAPS	650kg
Rotation Speed (V_R)	T/O	50 KIAS
Flap Retraction Speed (V_{OBS})	T/O	61 KIAS
Best Angle-of-Climb Speed (V_X)	0°	66 KIAS
Best Rate-of-Climb speed (V_Y)	0°	71 KIAS
Approach speed	T/O	61 KIAS
Final Approach Speed	FULL	55 KIAS
Touch Down Speed	FULL	55 KIAS
Manoeuvring speed (V_A)	0°	98 KIAS
Never Exceed Speed (V_{NE})	0°	143 KIAS

INTENTIONALLY LEFT BLANK

Supplement S4: pages replacement instructions

SECTION 5 – PERFORMANCE

**Make sure you first applied instructions reported on the
basic AFM and the Supplements (if applicable),
Section 5 Performance**

According A/C configuration apply following pages replacement:

Supplement S4 – Performance pages replace basic AFM Section 5 as a whole.

INTENTIONALLY LEFT BLANK

SECTION 5 - PERFORMANCE

INDEX

1. INTRODUCTION	2
2. USE OF PERFORMANCE CHARTS	2
3. AIRSPEED INDICATOR SYSTEM CALIBRATION	3
4. ICAO STANDARD ATMOSPHERE	4
5. STALL SPEED	5
6. CROSSWIND	6
7. TAKE-OFF PERFORMANCE	7
8. TAKE-OFF RATE OF CLIMB	11
9. EN-ROUTE RATE OF CLIMB	12
10. CRUISE PERFORMANCE	13
11. LANDING PERFORMANCE	15
12. BALKED LANDING PERFORMANCE	16
13. NOISE DATA	16

1. INTRODUCTION

This section provides all necessary data for an accurate and comprehensive planning of flight activity from take-off to landing.

Data reported in graphs and/or in tables were determined using:

- ✓ “Flight Test Data” under conditions prescribed by EASA CS-VLA regulation
- ✓ aircraft and engine in good condition
- ✓ average piloting techniques

Each graph or table was determined according to ICAO Standard Atmosphere (ISA - s.l.); evaluations of the impact on performance were carried out by theoretical means for:

- ✓ Airspeed
- ✓ External temperature
- ✓ Altitude
- ✓ Weight
- ✓ Runway type and condition

2. USE OF PERFORMANCE CHARTS

Performance data are presented in tabular or graphical form to illustrate the effect of different variables such as altitude, temperature and weight. Given information is sufficient to plan the mission with required precision and safety.

Additional information is provided for each table or graph.

3. AIRSPEED INDICATOR SYSTEM CALIBRATION

Graph shows calibrated airspeed V_{IAS} as a function of indicated airspeed V_{CAS} .

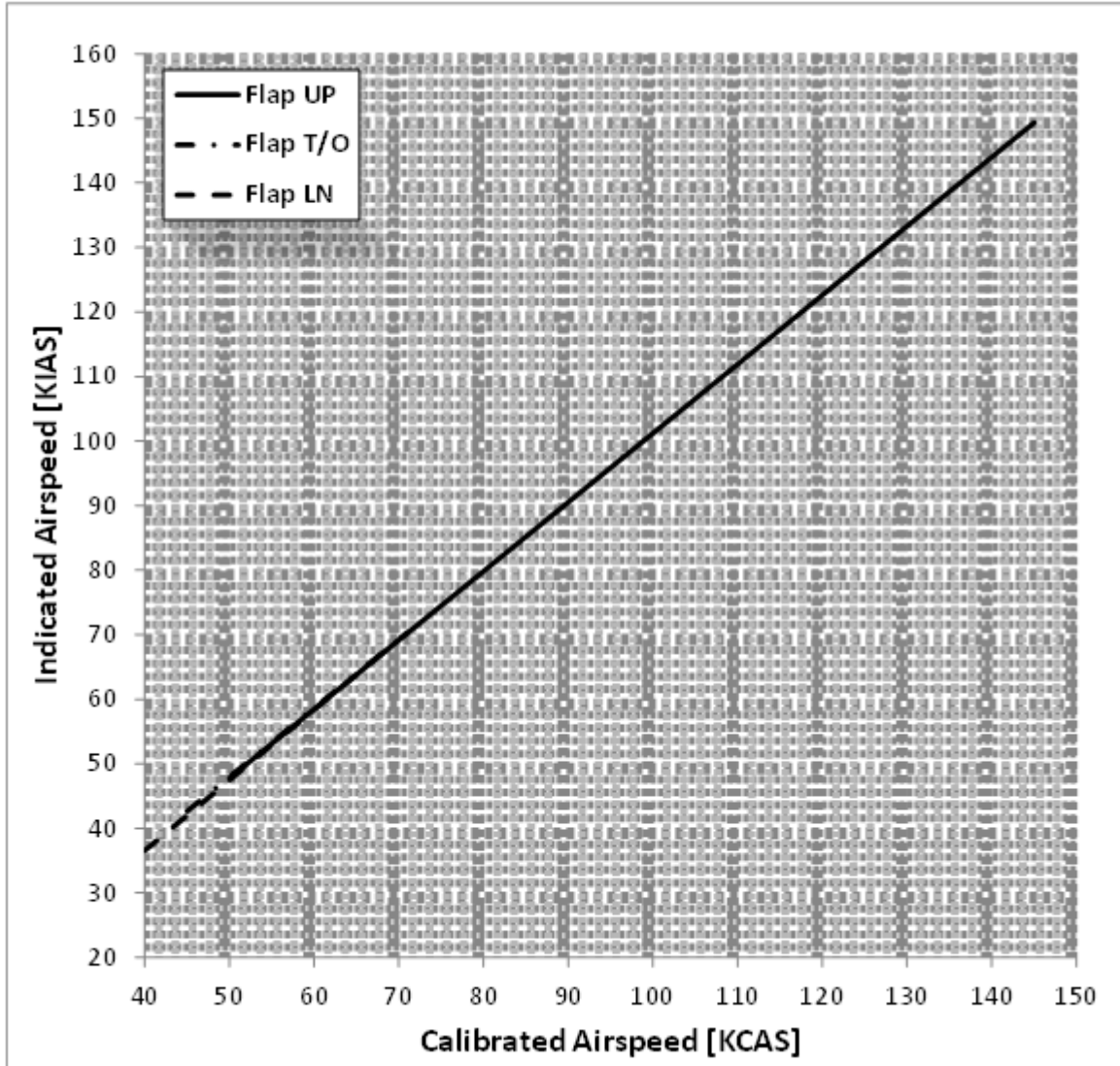

FIG. 5-1. CALIBRATED VS INDICATED AIRSPEED

Example:

Given

KIAS 75.0

Flap: UP

Find

KCAS 74.5

NOTE

Indicated airspeed assumes 0 as an instrument error

4. ICAO STANDARD ATMOSPHERE

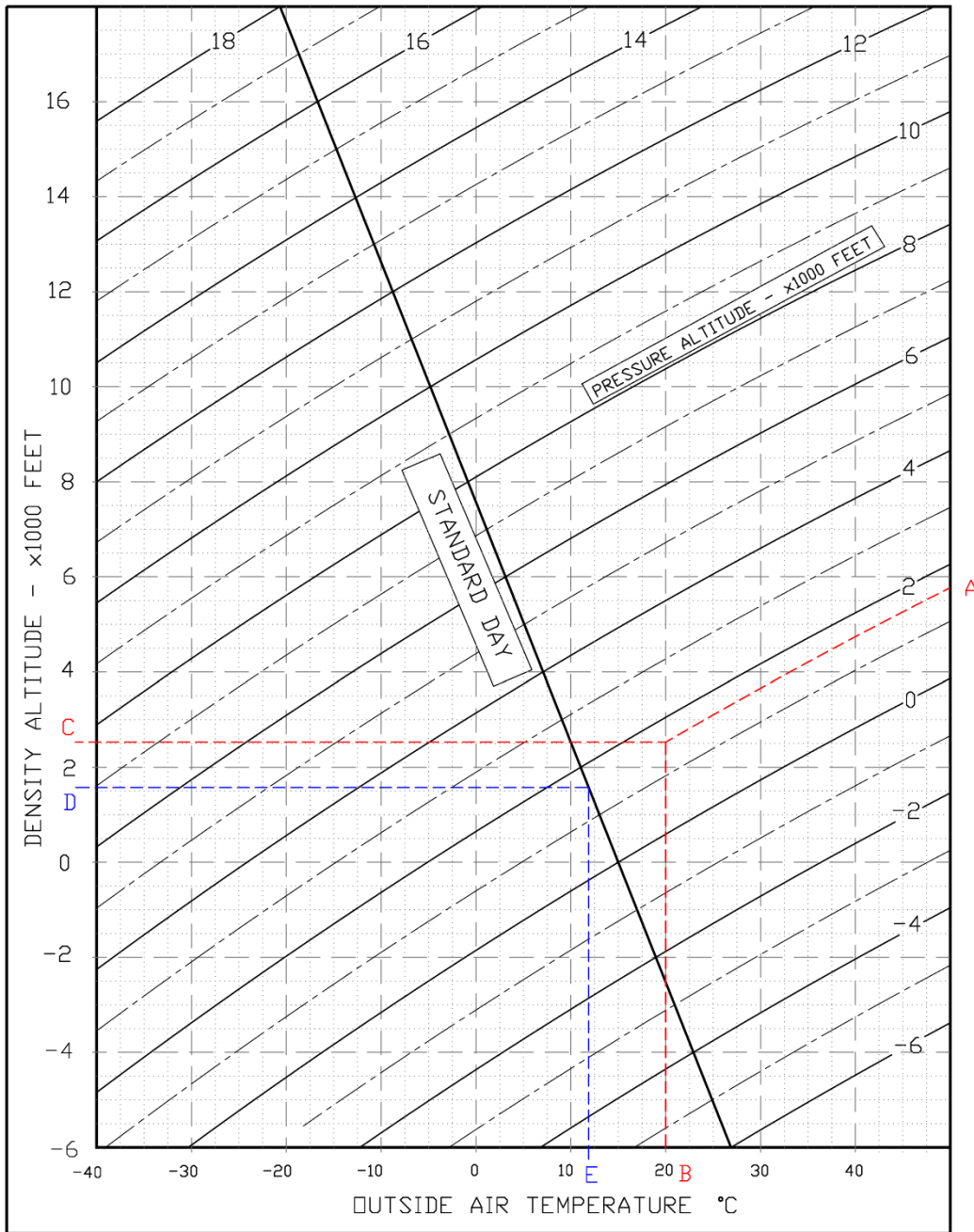

FIG. 5-2. ICAO CHART

Examples:

<u>Scope</u>	<u>Given</u>	<u>Find</u>
<u>DensityAltitude:</u>	A: Pressure altitude = 1600ft B: Temperature = 20°C	→ C: DensityAltitude = 2550ft
<u>ISA Temperature:</u>	D: Pressure altitude = 1600ft	→ E: ISA Air Temperature = 12°C

5. STALL SPEED

Weight: 650 kg Throttle Levers: IDLE CG: Most Forward (20%) No ground effect							
WEIGHT [kg]	BANK ANGLE [deg]	STALL SPEED					
		FLAPS 0°		FLAPS T/O		FLAPS FULL	
		KIAS	KCAS	KIAS	KCAS	KIAS	KCAS
650 (FWD C.G.)	0	49	51	46	48	40	44
	15	50	52	46	49	41	44
	30	53	55	49	51	44	47
	45	59	61	55	57	49	52
	60	71	72	67	67	60	62

NOTE

Altitude loss during conventional stall recovery, as demonstrated during flight tests is approximately 350 ft with banking below 30°.

6. CROSSWIND

Maximum demonstrated crosswind is 15Kts

⇒Example:

Given

Wind direction (with respect to aircraft longitudinal axis)= 30°

Wind speed = 20 Kts

Find

Headwind = 17.5 Kts

Crosswind = 10 Kts

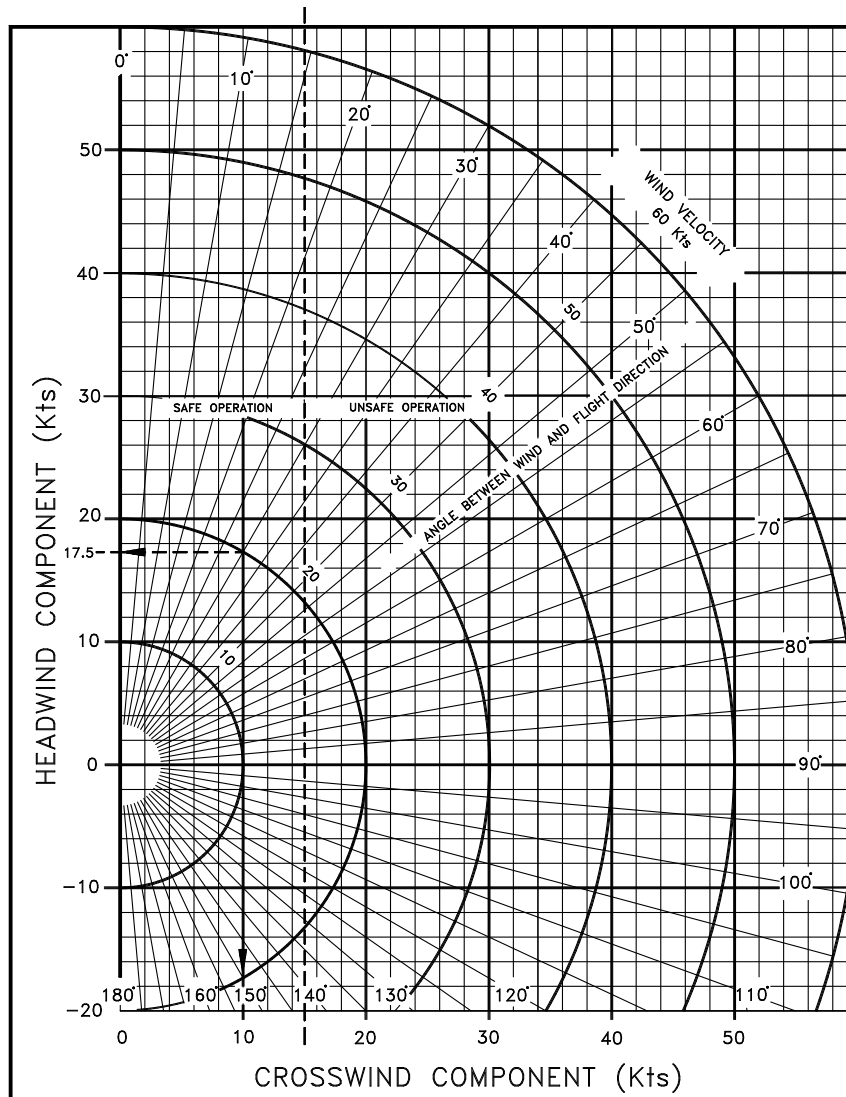

FIG. 5-2. CROSSWIND CHART

7. TAKE-OFF PERFORMANCE

NOTE

To account for likely in service performance variations apply a factored to distances of 1.10

Weight = 650 kg		Corrections				
Flaps: T/O		Headwind: - 5m for each kt (16ft/kt)				
Speed at Lift-Off = 48 KIAS		Tailwind: + 15m for each kt (49 ft/kt)				
Speed Over 50ft Obstacle = 60KIAS		Paved Runway: -10% to Ground Roll				
Throttle Levers: Full Forward		Runway slope: +7% to Ground Roll for each +1%				
Runway: Grass						
Pressure Altitude [ft]		Distance [m]				
		Temperature [°C]				ISA
		-25	0	25	50	
S.L.	Ground Roll	170	214	264	320	243
	At 50 ft AGL	285	356	436	526	403
1000	Ground Roll	185	233	288	349	261
	At 50 ft AGL	310	387	475	572	431
2000	Ground Roll	202	255	314	381	280
	At 50 ft AGL	337	421	516	623	462
3000	Ground Roll	221	278	343	416	301
	At 50 ft AGL	367	459	563	678	495
4000	Ground Roll	241	304	375	455	323
	At 50 ft AGL	400	500	613	739	531
5000	Ground Roll	264	332	410	497	347
	At 50 ft AGL	437	545	668	806	569
6000	Ground Roll	289	364	449	544	374
	At 50 ft AGL	476	595	729	879	611
7000	Ground Roll	316	398	491	596	402
	At 50 ft AGL	520	650	796	960	656
8000	Ground Roll	347	436	538	653	433
	At 50 ft AGL	568	710	870	1049	705
9000	Ground Roll	380	478	590	716	467
	At 50 ft AGL	621	776	951	1147	758
10000	Ground Roll	417	525	648	786	503
	At 50 ft AGL	679	849	1041	1255	815

Pressure Altitude [ft]		Distance [m]				
		Temperature [°C]				ISA
		-25	0	25	50	
S.L.	Ground Roll	157	198	244	296	225
	At 50 ft AGL	265	331	406	490	375
1000	Ground Roll	172	216	267	323	242
	At 50 ft AGL	289	361	442	533	402
2000	Ground Roll	187	236	291	353	259
	At 50 ft AGL	314	392	481	580	430
3000	Ground Roll	205	258	318	386	279
	At 50 ft AGL	342	427	524	631	461
4000	Ground Roll	224	281	347	421	299
	At 50 ft AGL	373	466	571	688	494
5000	Ground Roll	244	308	380	461	322
	At 50 ft AGL	406	508	622	750	530
6000	Ground Roll	268	337	416	504	346
	At 50 ft AGL	443	554	679	819	569
7000	Ground Roll	293	369	455	552	373
	At 50 ft AGL	484	605	741	894	611
8000	Ground Roll	321	404	499	605	401
	At 50 ft AGL	529	661	810	977	656
9000	Ground Roll	352	443	547	663	432
	At 50 ft AGL	578	722	885	1068	705
10000	Ground Roll	386	486	600	728	466
	At 50 ft AGL	632	790	969	1168	758

Weight = 630 kg

Corrections

Flaps: *T/O*

Speed at Lift-Off = 48 KIAS

Speed Over 50ft Obstacle = 60 KIAS

Throttle Levers: *Full Forward*

Runway: *Grass*

Headwind: - 5m for each kt (*16ft/kt*)

Tailwind: + 15m for each kt (*49 ft/kt*)

Paved Runway: -10% to Ground Roll

Runway slope: +7% to Ground Roll for each +1%

Weight = 580 kg		Corrections				
Flaps: T/O		Headwind: - 5m for each kt (16ft/kt)				
Speed at Lift-Off = 48 KIAS		Tailwind: + 15m for each kt (49 ft/kt)				
Speed Over 50ft Obstacle = 60 KIAS		Paved Runway: -10% to Ground Roll				
Throttle Levers: Full Forward		Runway slope: +7% to Ground Roll for each +1%				
Runway: Grass						
Pressure Altitude [ft]		Distance [m]				
		Temperature [°C]				ISA
		-25	0	25	50	
S.L.	Ground Roll	129	162	200	243	185
	At 50 ft AGL	219	274	335	404	310
1000	Ground Roll	141	177	219	265	198
	At 50 ft AGL	238	298	365	440	332
2000	Ground Roll	154	193	239	289	213
	At 50 ft AGL	259	324	397	478	355
3000	Ground Roll	168	211	261	316	228
	At 50 ft AGL	282	353	432	521	380
4000	Ground Roll	183	231	285	346	245
	At 50 ft AGL	308	384	471	568	408
5000	Ground Roll	200	252	311	378	264
	At 50 ft AGL	335	419	514	619	437
6000	Ground Roll	219	276	341	413	284
	At 50 ft AGL	366	457	560	676	469
7000	Ground Roll	240	302	373	453	305
	At 50 ft AGL	400	499	612	738	504
8000	Ground Roll	263	331	409	496	329
	At 50 ft AGL	436	545	668	806	541
9000	Ground Roll	289	363	448	544	354
	At 50 ft AGL	477	596	731	881	582
10000	Ground Roll	317	399	492	597	382
	At 50 ft AGL	522	652	799	964	626

Weight = 530 kg		Corrections				
Flaps: T/O		Headwind: - 5m for each kt (16ft/kt)				
Speed at Lift-Off = 48KIAS		Tailwind: + 15m for each kt (49 ft/kt)				
Speed Over 50ft Obstacle = 60 KIAS		Paved Runway: -10% to Ground Roll				
Throttle Levers: Full Forward		Runway slope: +7% to Ground Roll for each +1%				
Runway: Grass						
Pressure Altitude [ft]		Distance [m]				
		Temperature [°C]				ISA
		-25	0	25	50	
S.L.	Ground Roll	104	131	161	196	149
	At 50 ft AGL	178	222	272	328	251
1000	Ground Roll	113	143	176	214	160
	At 50 ft AGL	193	241	296	357	269
2000	Ground Roll	124	156	192	233	171
	At 50 ft AGL	210	263	322	388	288
3000	Ground Roll	135	170	210	255	184
	At 50 ft AGL	229	286	351	423	309
4000	Ground Roll	148	186	229	278	198
	At 50 ft AGL	250	312	382	461	331
5000	Ground Roll	161	203	251	304	213
	At 50 ft AGL	272	340	417	502	355
6000	Ground Roll	177	222	275	333	229
	At 50 ft AGL	297	371	455	548	381
7000	Ground Roll	194	244	301	365	246
	At 50 ft AGL	324	405	496	598	409
8000	Ground Roll	212	267	329	400	265
	At 50 ft AGL	354	442	542	654	439
9000	Ground Roll	232	293	361	438	285
	At 50 ft AGL	387	484	593	715	472
10000	Ground Roll	255	321	396	481	308
	At 50 ft AGL	423	529	648	782	508

8. TAKE-OFF RATE OF CLIMB

NOTE

To account for likely in service performance variations apply a factored to rate of climb of 0.90

Throttle Lever: Full Forward Flaps: Take-Off							
Weight [kg]	Pressure Altitude [ft]	Climb Speed V _y [KIAS]	Rate of Climb [ft/min]				
			Temperature [°C]				ISA
			-25	0	25	50	
650	S.L.	67	1008	828	667	521	729
	2000	66	871	694	535	392	621
	4000	66	734	560	404	263	514
	6000	65	598	426	273	135	407
	8000	65	462	293	143	7	299
	10000	64	326	161	13	-120	192
	12000	63	191	29	-116	-247	84
	14000	63	57	-103	-245	-373	-23
630	S.L.	67	1055	870	706	558	770
	2000	66	915	733	572	426	660
	4000	66	775	597	438	295	550
	6000	65	636	461	305	164	441
	8000	64	497	325	172	34	331
	10000	64	359	190	40	-96	221
	12000	63	221	56	-92	-226	112
	14000	63	84	-79	-224	-355	2
580	S.L.	67	1182	987	814	657	881
	2000	66	1034	843	672	518	765
	4000	65	887	698	530	379	649
	6000	65	739	555	390	241	533
	8000	64	593	411	249	103	417
	10000	63	447	269	109	-34	302
	12000	63	301	126	-30	-171	186
	14000	62	156	-16	-169	-307	70
530	S.L.	66	1331	1123	937	770	1009
	2000	66	1173	968	786	622	886
	4000	65	1015	815	635	474	762
	6000	64	858	661	485	326	638
	8000	64	702	508	335	179	515
	10000	63	546	356	186	33	391
	12000	63	391	204	37	-113	268
	14000	62	236	53	-111	-259	144

9. EN-ROUTE RATE OF CLIMB

NOTE

To account for likely in service performance variations apply a factored to rate of climb of 0.90

Throttle Lever: Full Forward							
Flaps: UP							
Weight [kg]	Pressure Altitude [ft]	Climb Speed V _y [KIAS]	Rate of Climb [ft/min]				
			Temperature [°C]				ISA
			-25	0	25	50	
650	S.L.	71	999	851	719	600	770
	2000	70	887	741	611	494	682
	4000	68	774	631	503	388	594
	6000	67	663	522	396	283	506
	8000	65	551	413	289	178	417
	10000	64	440	304	183	74	329
	12000	63	329	196	77	-31	241
	14000	61	219	88	-29	-134	153
630	S.L.	71	1045	894	759	637	811
	2000	70	930	782	649	529	721
	4000	68	816	670	539	422	631
	6000	67	702	558	430	314	541
	8000	65	588	447	321	207	451
	10000	64	474	336	212	101	362
	12000	62	361	225	104	-5	272
	14000	61	249	115	-4	-111	182
580	S.L.	71	1171	1011	869	740	924
	2000	69	1050	893	753	626	829
	4000	68	929	774	637	513	734
	6000	66	808	657	521	399	639
	8000	65	688	539	406	286	544
	10000	64	568	422	291	174	449
	12000	62	449	305	177	62	354
	14000	61	330	189	63	-50	259
530	S.L.	71	1317	1147	995	858	1054
	2000	69	1188	1021	871	737	953
	4000	68	1059	895	748	616	852
	6000	66	931	769	625	495	751
	8000	65	803	644	502	375	649
	10000	63	675	519	380	255	548
	12000	62	548	395	259	135	447
	14000	60	421	271	137	16	346

10. CRUISE PERFORMANCE



Propeller speed over 2265 RPM is restricted to 5min.

Weight = 630 kg							
CORRECTIONS							
	KTAS	Fuel Consumption	Endurance	Range	Specific Range		
For each +15°C of OAT	-2%	-2.5%	+2%	+1%	+1%		
For each -15°C of OAT	+1%	+3%	-4%	-2%	-1%		
For -100kg of weight	+3.3%	-	-	+3%	+4%		
CRUISE PERFORMANCE							
Pressure Altitude [ft]	OAT ISA [deg C]	Propeller RPM	KTAS	Fuel Consumption [lt/hr]	Endurance [hr:mm]	Range [nm]	Specific Range [nm/lt]
0	15	2388	120	25.8	4:40	562	4.64
		2250	110	21.3	5:40	624	5.16
		2100	99	17.4	7:00	689	5.70
		2000	92	15.3	7:50	725	5.99
		1900	85	13.7	8:45	748	6.18
		1800	78	12.5	9:40	751	6.21
2000	11	2388	118	24.1	5:00	593	4.90
		2250	108	20.0	6:00	653	5.40
		2100	98	16.6	7:20	712	5.89
		2000	90	14.8	8:10	740	6.12
		1900	83	13.4	9:00	752	6.22
		1800	76	12.4	9:45	743	6.15

Weight = 630 kg							
CORRECTIONS							
	KTAS	Fuel Consumption	Endurance	Range	Specific Range		
For each +15°C of OAT	-2%	-2.5%	+2%	+1%	+1%		
For each -15°C of OAT	+1%	+3%	-4%	-2%	-1%		
For -100kg of weight	+3.3%	-	-	+3%	+4%		
CRUISE PERFORMANCE							
Pressure Altitude [ft]	OAT ISA [deg C]	Propeller RPM	KTAS	Fuel Consumption [lt/hr]	Endurance [hr:mm]	Range [nm]	Specific Range [nm/lt]
4000	7	2388	117	22.6	5:25	624	5.16
		2250	107	18.9	6:25	681	5.63
		2100	96	15.9	7:35	731	6.04
		2000	89	14.3	8:25	750	6.20
		1900	82	13.2	9:10	750	6.21
		1800	75	12.4	9:45	728	6.02
6000	3	2250	105	18.0	6:40	706	5.84
		2100	94	15.3	7:50	744	6.16
		2000	87	14.0	8:35	753	6.22
		1900	80	13.1	9:25	741	6.13
		1800	73	12.5	9:40	705	5.83
8000	-1	2250	103	17.2	7:00	726	6.01
		2100	93	14.9	8:05	752	6.22
		2000	85	13.8	8:45	748	6.19
		1900	78	13.1	9:10	723	5.98
10000	-5	2100	91	14.6	8:20	752	6.22
		2000	84	13.7	8:45	735	6.08
		1900	76	13.3	9:05	698	5.77

11. LANDING PERFORMANCE

NOTE

To account for likely in service performance variations apply a factored to distances of 1.67

Weight = 650 kg		Corrections				
Flaps: LAND		Headwind: -4m for each kt (13 ft/kt)				
Short Final Approach Speed = 54 KIAS		Tailwind: + 13m for each kt (43 ft/kt)				
Throttle Levers: Idle		Paved Runway: -10% to Ground Roll				
Runway: Grass		Runway slope: -3% to Ground Roll for each +1%				
Pressure Altitude [ft]		Distance [m]				
		Temperature [°C]				ISA
		-25	0	25	50	
S.L.	Ground Roll	149	164	179	194	173
	At 50 ft AGL	358	373	388	403	382
1000	Ground Roll	154	170	186	201	178
	At 50 ft AGL	363	379	395	410	387
2000	Ground Roll	160	176	192	209	183
	At 50 ft AGL	369	385	401	418	392
3000	Ground Roll	166	183	200	216	189
	At 50 ft AGL	375	392	409	425	398
4000	Ground Roll	172	190	207	225	195
	At 50 ft AGL	381	399	416	434	404
5000	Ground Roll	179	197	215	233	201
	At 50 ft AGL	388	406	424	442	410
6000	Ground Roll	186	205	223	242	207
	At 50 ft AGL	395	414	432	451	416
7000	Ground Roll	193	212	232	251	213
	At 50 ft AGL	402	421	441	460	422
8000	Ground Roll	200	221	241	261	220
	At 50 ft AGL	410	430	450	470	429
9000	Ground Roll	208	229	250	271	227
	At 50 ft AGL	417	438	459	480	436
10000	Ground Roll	217	238	260	282	234
	At 50 ft AGL	426	447	469	491	443

12. BALKED LANDING PERFORMANCE

NOTE

To account for likely in service performance variations apply a factored to rate of climb and to angle of climb of 0.90

Throttle Lever: Full Forward							
Flaps: Take-Off							
Speed: 60 KIAS							
Weight	Pressure Altitude	Rate of Climb [ft/min] (angle of climb [deg])					
		Temperature [°C]				ISA	
[kg]	[ft]	-25	0	25	50		
650	S.L.	836 (8°)	708 (7°)	594 (5°)	491 (4°)	638 (6°)	
	2000	739 (7°)	613 (6°)	501 (4°)	400 (3°)	562 (5°)	
	4000	642 (6°)	518 (5°)	408 (3°)	309 (3°)	486 (4°)	
	6000	545 (5°)	424 (4°)	316 (3°)	218 (2°)	410 (3°)	
	8000	449 (4°)	330 (3°)	224 (2°)	128 (1°)	334 (3°)	
	10000	353 (3°)	236 (2°)	132 (1°)	37 (0°)	258 (2°)	
	12000	258 (2°)	143 (1°)	40 (0°)	-52 (-0°)	182 (1°)	
	14000	162 (1°)	50 (0°)	-51 (-0°)	-142 (-1°)	105 (1°)	

13. NOISE DATA

Noise level, determined in accordance with ICAO/Annex 16 6th Ed., July 2011, Vol. I°, Chapter 10, is **70.16 dB(A)**.

Supplement S4: pages replacement instructions

SECTION 6 – WEIGHT AND BALANCE

**Make sure you first applied instructions reported on the
basic AFM and the Supplements (if applicable),
Section 6 Weight and Balance**

According A/C configuration apply following pages replacement:

Supplement S4 – WEIGHT AND BALANCE page		AFM or Supplement Section 6 page
6W-5	REPLACES	Page 6-5 of basic AFM, Section 6
6W-6	REPLACES	Page 6-6 of basic AFM, Section 6
6W-9	REPLACES	Page 6-9 of basic AFM, Section 6

INTENTIONALLY LEFT BLANK

2.5. WEIGHING RECORD

Model **P2008 JCS/N:** _____ Weighing no. _____ Date: _____

Datum: Propeller Flange

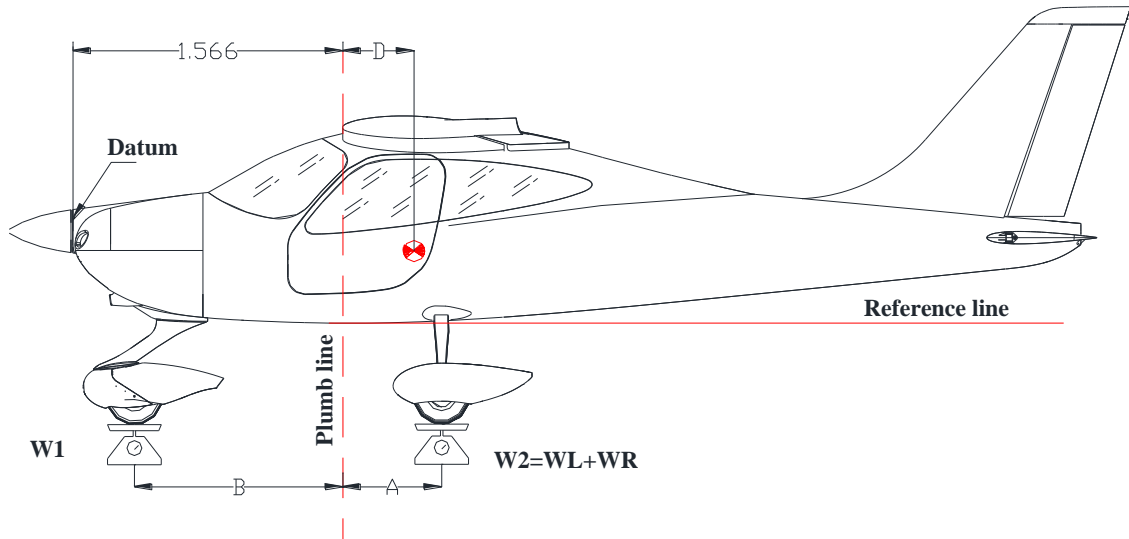

	<i>Kg or Lbs</i>		<i>Meters or feet</i>
Nose wheel weight	$W_1 =$	Plumb bob distance LH wheel	$A_L =$
LH wheel weight	$W_L =$	Plumb bob distance RH wheel	$A_R =$
RH wheel weight	$W_R =$	Average distance $(A_L + A_R)/2$	$A =$
$W_2 = W_L + W_R =$		Plumb bob distance from nose wheel	$B =$

Empty weight $W_e = W_1 + W_2 =$ _____ [kg] or [lbs]

$D = \frac{W_2 \cdot A - W_1 \cdot B}{W_e}$ [m] or [Ft] $D\% = \frac{D}{1.373 \text{ m (or 4.5 ft)}} \cdot 100 =$ _____

Empty weight moment: $M = [(D+1.566) \cdot W_e] =$ _____ [m · kg] or [ft · lbs]

Maximum takeoff weight	$W_T = 650 \text{ kg}$	(1433 lbs)	Signature _____ _____
Empty weight	$W_e =$	[kg] or [lbs]	
Max. useful load $W_T - W_e$	$W_u =$	[kg] or [lbs]	

2.6. WEIGHING RECORD (II)

Model **P2008 JCS/N:** _____ Weighing no. _____ Date: _____

Datum: Propeller Flange

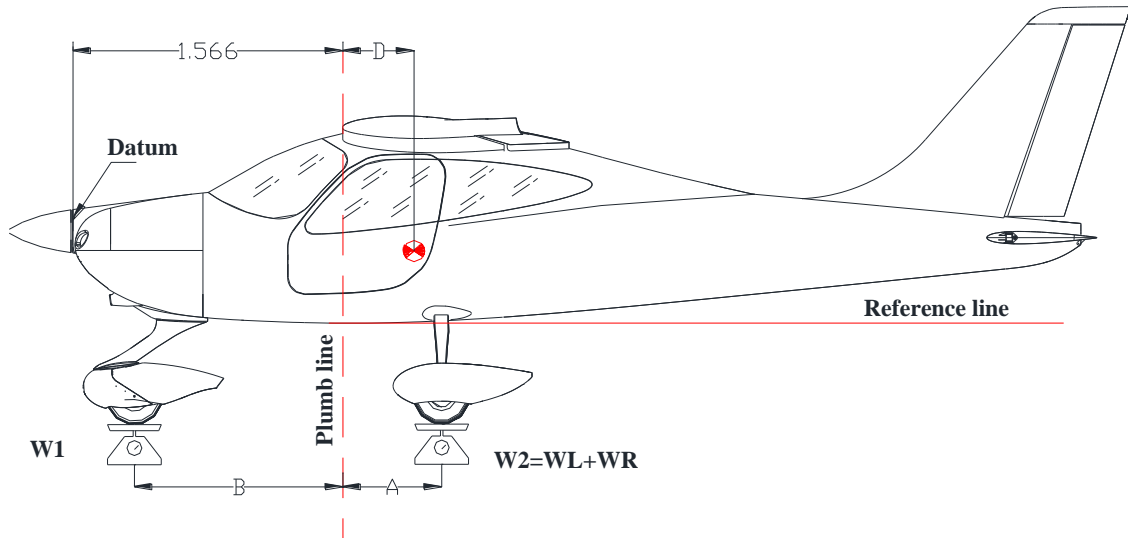

	<i>Kg or Lbs</i>		<i>Meters or feet</i>
Nose wheel weight	$W_1 =$	Plumb bob distance LH wheel	$A_L =$
LH wheel weight	$W_L =$	Plumb bob distance RH wheel	$A_R =$
RH wheel weight	$W_R =$	Average distance $(A_L + A_R)/2$	$A =$
$W_2 = W_L + W_R =$		Plumb bob distance from nose wheel	$B =$

Empty weight $W_e = W_1 + W_2 =$ [kg] or [lbs]

$$D = \frac{W_2 \cdot A - W_1 \cdot B}{W_e} = [\text{m}] \text{ or } [\text{ft}] \quad D\% = \frac{D}{1.373 \text{ m (or 4.5 ft)}} \cdot 100 =$$

Empty weight moment: $M = [(D + 1.566) \cdot W_e] =$ [m · kg] or [ft · lbs]

Maximum takeoff weight	$W_T = 650 \text{ kg}$	(1433 lbs)	Signature _____ _____
Empty weight	$W_e =$	[kg] or [lbs]	
Max. useful load $W_T - W_e$	$W_u =$	[kg] or [lbs]	

C.G.Range	Max FWD	Max AFT
Meters	1.841	1.978

Max Weight	Pounds	Kilograms
	1433.00	650.00

Example						
	Weight		Arm		Moment	
	<i>lbs</i>	<i>kg</i>	<i>in</i>	<i>m</i>	<i>lbs in</i>	<i>kg m</i>
Empty	813.5	369.0	74.4	1.89	60533	697.4
Fuel	150.0	68.0	87.0	2.21	13052	150.4
Pax	300.0	136.1	70.9	1.80	21270	245.1
Baggage	0	0	94.9	2.41	0	0
Total	1263.5	573.1	75.1	1.91	94854	1092.8

In this example, the gross weight is under the max gross weight and the Arm or C.G. is within the C.G. range listed above.

4. BAGGAGE LOADING

The baggage loading in the dedicated compartment, behind the pilots' seats, must be carried out in accordance with C.G. excursion and weight limitations reported in Section 2.

Baggage must be uniformly distributed on compartment floor.

Pilot is provided with a red tie-down net and snap fasteners allowing for securing the loads on the compartment floor.



CAUTION

Loading the baggage, make sure that you correctly stretched the net which must be secured to the four vertices of the compartment.

INTENTIONALLY LEFT BLANK

Supplement S4: pages replacement instructions

SECTION 7 – AIRFRAME AND SYSTEMS DESCRIPTION

**Make sure you first applied instructions reported on the
basic AFM and on the Supplements (if applicable),
Section 7 Airframe and Systems Description**

According to A/C configuration refer to the basic AFM, Section 7 – Airframe and Systems Description or S1 (VFR night), section 7 – Airframe and Systems Description

INTENTIONALLY LEFT BLANK

Supplement S4: pages replacement instructions

SECTION 8 – GROUND HANDLING & SERVICE

**Make sure you first applied instructions reported on the
basic AFM and on the Supplements (if applicable),
Section 8 Ground Handling & Service**

Refer to the basic AFM, Section 8 – Ground Handling & Service.

SUPPLEMENT NO. S5
ARGENTINE AIRCRAFT FLIGHT MANUAL SUPPLEMENT

Record of Revisions

Rev	Revised page	Description of Revision	Tecnam Approval			EASA Approval or Under DOA Privileges
			DO	OoA	HDO	
0	-	Editorial change	A. Sabino	C.Caruso	M. Oliva	DOA

List of Effective Pages

Page	Revision	Page	Revision
S5-1	Rev 0		
S5-2	Rev 0		
S5-3	Rev 0		
S5-4	Rev 0		

INTRODUCTION

This supplement contains supplementary information for a safe and efficient operation of the aircraft delivered in the Argentina

For limitations, procedures, and performance information not contained in this supplement, refer to the EASA Approved Aircraft Flight Manual.

LIMITATION

The information contained herein complements or supersedes the basic information in the EASA Approved Aircraft Flight Manual.

WARNING: Limitations, operation under Normal and Emergency Procedures, Performances & Weighing Instructions associated to:

- **650 Kg MTOW:** are only applicable for Aircrafts after install Service Bulletin SB 171-CS or Design Change MOD 2008/027.

FUEL

APPROVED FUEL

- MOGAS ASTM D4814
- AVGAS 100 LL (ASTM D910)

LIMITATION PLACARDS

On the right side of the instrument panel the following placard is placed reminding the observance for “NO FUMAR”:



Near baggage compartment a placard will state the following:

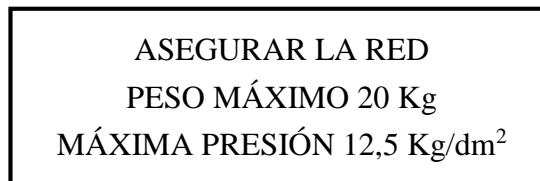

OTHER PLACARDS

Allowed fuel placard

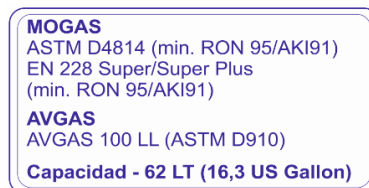

Emergency Exit placard



Safety equipment location placard



ELT placard



Battery placard

**BATERIA DENTRO
DETRÀS DE
ESTE PANEL**

Door lock lever

CERRADO

ABIERTO

Backrest lever placard

**RESPALDO : PRESIONAR
PARA DESTABAR**

SUPPLEMENT NO. S6
AIRCRAFT FLIGHT MANUAL SUPPLEMENT
FOR MOGAS MG95 IS 2796:2017

Record of Revisions

Rev	Revised page	Description of Revision	Tecnam Approval			EASA Approval or Under DOA Privileges
			DO	OoA	HDO	
0	-	Editorial change	A. Sabino	C. Caruso	M. Oliva	EASA Approval No. 0010059501
1	1, 2, 4	MOD2008/210	F. Paloni	D. Ronca	M. Oliva	EASA Approval 10084361
2	1	Typos corrections	F. Paloni	D. Ronca	M. Oliva	Approved under the authority of DOA, ref. EASA.21J.335 (MOD2008/237.250715)

List of Effective Pages

Page	Revision	Page	Revision
S6-1	Rev 2		
S6-2	Rev 1		
S6-3	Rev 0		
S6-4	Rev 1		

INTRODUCTION

This supplement contains supplemental information to the basic information approved in EASA aircraft Flight Manual when the aircraft is modified with type certificate change MOD2008/077 or MOD2008/210.

For Limitations, procedures, and performance information not contained in this supplement, refer to the basic Aircraft Flight Manual.

SECTION 2 – LIMITATIONS

The following pages should be added to the basic AFM,

5. FUEL

The following fuel should be added to the ones listed in section 2 of the original AFM

MOGAS

- MOGAS MG 95 compliant to IS 2796:2017

NOTE: For additional information, refer to Rotax Service Instruction No. 912-016, latest issue.

22. OTHER PLACARDS

The following fuel placard should be added to the one listed in section 2 of the original AFM

MOGAS
ASTM D4814 (min. RON 95/AKI91)
EN 228 Super/Super Plus
(min. RON 95/AKI91)
IS 2796:2008 (MG 95)
AVGAS
AVGAS 100 LL (ASTM D910)
Capacity - 62 LT (16,3 US Gallon)

or

MOGAS
ASTM D4814 (min. RON 95/AKI91)
EN 228 Super/Super Plus
(min. RON 95/AKI91)
IS 2796:2017 (MG 95)
AVGAS
AVGAS 100 LL (ASTM D910)
Capacity - 62 LT (16,3 US Gallon)

Supplement no. S7

**AFMS FOR
Hoffman propeller equipped airplanes with
MTOW Increment at 650 kg**

Record of Revisions

Rev	Revised page	Description of Revision	Tecnam Approval			EASA Approval or Under DOA Privileges
			DO	OoA	HDO	
0	All	Editorial revision.	A. Sabino	C. Caruso	M. Oliva	DOA Approval
1	WH2-6	Table format edited.	A. Sabino	C. Caruso	M. Oliva	Approved under the authority of DOA, ref. EASA.21J.335 (MOD2008/103.180312)
	WH2-9	Amended caution on supplemental oxygen use.				
	WH4-4	Information added to normal operation speeds' table.				
	WH5-12 thru 13	Cruise performance amended.				
	WH6-9	W&B calculation sample.				
	WHN4-3, WH3-22, WHN3-23, WH4-15, 16, WH6-10 thru 12	Pages removed, information included in basic AFM.				
2	S7-1	LOEP correction	A. Sabino	D. Ronca	M. Oliva	DOA Approval Nr. MOD2008/113.190404
3	S7-1, 8	LOEP correction	A. Sabino	D. Ronca	M. Oliva	DOA Approval Nr. MOD2008/123.190620
4	S7-9, WH5-15, WH7-10	Typo on noise data Page number correction	G. Valentino	D. Ronca	M. Oliva	Approved under the authority of DOA, ref. EASA.21J.335 (MOD2008/143.200730)
5	S7-1, WHN4-4	RoR and LoEP update Typo error correction	L. De Salvi	D. Ronca	M. Oliva	Approved under the authority of DOA, ref. EASA.21J.335 (MOD2008/188.230126)
6	S7-1, 2, 6	Typo errors correction	F. Losappio	D. Ronca	M. Oliva	authority of DOA, ref. EASA.21J.335 (MOD2008/237.250715)

List of Effective Pages

	Page	Revision
Cover Pages	S7-8	<i>Rev 3</i>
	S7-3,4,5,7,10	<i>Rev 1</i>
	S7-9	<i>Rev 4</i>
	S7-1,2,6	<i>Rev 6</i>
Section 1	WH1-6 thru 7	<i>Rev 0</i>
Section 2	WH2-5 thru 6, WH2-12, WH2-16 thru 17 WH2-21, WHN2-21	<i>Rev 0</i>
	WH2-9	<i>Rev 1</i>
Section 3	WH3-9, WH3-21	<i>Rev 0</i>
Section 4	WHN4-4	<i>Rev 5</i>
Section 5	WH5-1 thru 11, 14, 16	<i>Rev 0</i>
	WH5-12 thru 13	<i>Rev 1</i>
	WH5-15	<i>Rev 4</i>
Section 6	WH6-5 thru 6	<i>Rev 0</i>
	WH6-9	<i>Rev 1</i>
Section 7	WH7-10	<i>Rev 4</i>

INTRODUCTION

This section contains supplemental information to operate, in a safe and efficient manner, the aircraft when equipped with Hoffman propeller with MTOW increment at 650 Kg.

It is the owner's responsibility to replace the mentioned pages in accordance with the instructions herein addressed section by section.

Supplement S7: pages replacement instructions
--

SECTION 1 – GENERAL

**Make sure you first applied instructions reported on the basic AFM,
Section 1 General**

According A/C configuration apply following pages replacement:

Supplement S7 GENERAL page		AFM Section 1 page
WH1-6 thru 7	REPLACES	Page 1-6 thru 7 of basic AFM, Section 1

5 ENGINE

Manufacturer	Bombardier-Rotax GmbH
Model	912 S2
Engine type	4 cylinders horizontally opposed with 1352 c.c. of overall displacement, liquid cooled cylinder heads, ram-air cooled cylinders, two carburetors, integrated reduction gear box with torsional shock absorber and overload clutch.
Maximum power (at declared rpm)	73.5 kW (98.6hp) @ 5800 rpm –5 minutes maximum. 69.0 kW (92.5hp) @ 5500 rpm (continuous)

6 PROPELLER

Manufacturer	Hoffman Propeller
Model	HO17GHM A 174 177C
Blades	2 blades of Laminated hard wood. Composite structure, epoxy fibre glass cover
Diameter	1740 mm
Type	Fixed pitch

7. FLIGHT CONTROL SURFACES TRAVEL

Ailerons	Up 22° Down 14 ° (± 2°)
Stabilator (refer to Trailing Edge)	Up 4° Down 15° (± 2°)
Stabilator trim tab (refer to Trailing Edge)	Up 2°; Down 12° (± 1°)
Rudder	RH 25° LH 25° (± 2°)
Flaps	0°; 35° (± 1°)

8. SPECIFIC LOADINGS

	MTOW 650 kg (1433lb)
Wing Loading	53.5 kg/m ² (10.9 lb/sqft)
Power Loading	6.59 kg/hp (14.53 lb/hp)

Supplement S7: pages replacement instructions

SECTION 2 – LIMITATIONS

**Make sure you first applied instructions reported on the basic AFM,
Section 2 Limitations**

According A/C configuration apply following pages replacement:

Supplement S7 pages		Basic AFM pages	Supplement S1 pages
WH2-5 thru 6	REPLACE	2-5 thru 6	/
WH2-9	REPLACES	2-9	/
WH2-12	REPLACES	2-12	/
WH2-16 thru 17	REPLACE	2-16 thru 17	/
WH2-21	REPLACES	2-21	/
WHN2-21	REPLACES	/	2N-21

2. AIRSPEED LIMITATIONS

The following table addresses the airspeed limitations and their operational significance:

AIRSPEED		KIAS	KCAS	REMARKS
V _{NE}	Never exceed speed	143	139	Do not exceed this speed in any operation.
V _{NO}	Maximum Structural Cruising speed	111	110	Do not exceed this speed except in smooth air, and only with caution.
V _A	Design Manoeuvring speed	98	97	Do not make full or abrupt control movement above this speed, because under certain conditions the aircraft may be overstressed by full control movement.
V _O	Operating Manoeuvring speed			
V _{FE}	Maximum flaps extended speed	70	71	Do not exceed this speed for indicated flaps setting.

3. AIRSPEED INDICATOR MARKINGS

Airspeed indicator markings and their colour code are explained in the following table.

MARKING	KIAS	EXPLANATION
White arc/band	40 – 70	Positive Flap Operating Range (lower limit is V_{SO} , at specified maximum weight and upper limit is the maximum speed permissible with landing flaps extension).
Green arc/band	49 – 111	Normal Operating Range (lower limit is V_{S1} at specified maximum weight and most forward c.g. with flaps retracted and upper limit is maximum structural speed V_{NO}).
Yellow arc/band	111 – 143	Manoeuvres must be conducted with caution and only in smooth air.
Red line	143	Maximum speed for all operations.

9. PROPELLER

MANUFACTURER:	Hoffman Propeller
MODEL:	HO17GHM A 174 177C
BLADES:	2 blades of Laminated hard wood. Composite structure, epoxy fibre glass cover
TYPE:	Fixed pitch
DIAMETER:	1740 mm

10. MAXIMUM OPERATING ALTITUDE

Maximum operating altitude is 13000ft (3962 m) MSL.



CAUTION

Flight crew is required to use supplemental oxygen according to applicable Air Operation Rules.

11. AMBIENT TEMPERATURE

Ambient temperature: from -25°C to +50°C.



WARNING

Flight in expected and/or known icing conditions is forbidden.

14. WEIGHTS

Condition	Weight	
Maximum takeoff weight	650 kg	1433lb
Maximum landing weight	650 kg	1433lb

Baggage Compartment		
Maximum weight	20 kg	44lb
Maximum specific pressure	12,5 kg/dm ²	256 lbs/sq in

16. APPROVED MANOEUVRES

The aircraft is certified in Normal Category in accordance with EASA CS-VLA regulation applying to aeroplanes intended for non-aerobatic operation only.

Non aerobatic operation includes:

- Any manoeuvre pertaining to “normal” flight
- Stalls (except whip stalls)
- Lazy eights
- Chandelles
- Steep turns in which the angle of bank is not more than 60°

Recommended entry speeds for each approved manoeuvre are as follows:

Manoeuvre	Speed [KIAS]
Lazy eight	98
Chandelle	111
Steep turn (max 60°)	98
Stall	Slow deceleration (1 kts/s)



Acrobatic manoeuvres, including spins and turns with angle of bank of more than 60°, are not approved for such a category.



Limit load factor could be exceeded by moving abruptly flight controls at their end run at a speed above V_A (Manoeuvring Speed: 98 KIAS).



Flight in expected and/or known icing conditions, in proximity of storms or in severe turbulence is forbidden.

17. MANOEUVRES LOAD FACTOR LIMITS

Manoeuvre load factors limits are as follows:

Positive	Negative
+ 3.8 g	- 1.9 g

Manoeuvre load factors limits with flaps extended are as follows:

Positive	Negative
+ 1.9 g	0 g

21. LIMITATIONS PLACARDS

The following limitation placards are placed in plain view on the pilot.

On the left side instrument panel, above on the left, it is placed the following placard reporting the speed limitations:

Manoeuvring Speed
V_A = 98 kts

On the central side of the instrument panel, the following placard is placed reminding the observance of aircraft operating limitations according to installed equipment configuration (see KOEL, Para. 20):

This a/c is classified as VLA
approved for
DAY VFR
(with required equipment)
in non-icing conditions.
all aerobatics manoeuvres
including spinning are prohibited.
For operating limitations
refer to KOEL in the
FLIGHT MANUAL

On the right hand side of the instrument panel the following placard is placed reminding the observance for “no smoking”:

NO SMOKING

In the baggage compartment following placard is placed:

TIE-DOWN HARNESS
MAX WEIGHT 20kg [44 lbs]

DO NOT PLACE SHARP
OBJECTS ON THE FLOOR

21. LIMITATIONS PLACARDS

The following limitation placards are placed in plain view on the pilot.

On the left side instrument panel, above on the left, it is placed the following placard reporting the speed limitations:

Manoeuvring Speed
V_A = 98 kts

On the central side of the instrument panel, the following placard is placed reminding the observance of aircraft operating limitations according to installed equipment configuration (see KOEL, Para. 20):

This a/c is classified as VLA
approved for
DAY OR NIGHT VFR
(with required equipment)
in non-icing conditions.
all aerobatics manoeuvres
including spinning are prohibited.
For operating limitations
refer to KOEL in the
FLIGHT MANUAL

On the right hand side of the instrument panel the following placard is placed reminding the observance for “no smoking”:

NO SMOKING

In the baggage compartment following placard is placed:

TIE-DOWN HARNESS
MAX WEIGHT 20kg [44 lbs]

DO NOT PLACE SHARP
OBJECTS ON THE FLOOR

Supplement S7: pages replacement instructions

SECTION 3 – EMERGENCY PROCEDURES

**Make sure you first applied instructions reported on the basic AFM,
Section 3 Emergency Procedures**

According A/C configuration apply following pages replacement:

Supplement S7 pages		Basic AFM pages
WH3-9	REPLACES	3-9
WH3-21	REPLACES	3-21

5. ENGINE FAILURE

5.1. ENGINE FAILURE DURING TAKE-OFF RUN

- | | |
|--------------|------------------------------|
| 1. Throttle: | <i>IDLE (keep fully out)</i> |
| 2. Rudder: | <i>Keep heading control</i> |
| 3. Brakes: | <i>apply as needed</i> |

When safely stopped:

- | | |
|---------------------------------|-------------|
| 4. Ignition key: | <i>OFF.</i> |
| 5. Fuel selector valve: | <i>OFF</i> |
| 6. Electric fuel pump: | <i>OFF</i> |
| 7. Alternator& Master switches: | <i>OFF.</i> |

5.2. ENGINE FAILURE IMMEDIATELY AFTER TAKE-OFF

- | | |
|--|-----------------------------|
| 1. Speed: | <i>keep minimum 61 KIAS</i> |
| 2. Find a suitable place to land safely. | |



The immediate landing should be planned straight ahead with only small changes in directions not exceeding 45° to the left or 45° to the right.

- | | |
|-----------|------------------|
| 3. Flaps: | <i>as needed</i> |
|-----------|------------------|



Stall speed increases with bank angle and longitudinal load factor. Acoustic stall warning will in any case provides a correct anticipated cue of incipient stall.

At, or right before, touch down

- | | |
|---------------------------------|----------------------------------|
| 4. Throttle: | <i>IDLE (fully out and hold)</i> |
| 5. Ignition key: | <i>OFF</i> |
| 6. Fuel selector valve: | <i>OFF</i> |
| 7. Electric fuel pump: | <i>OFF</i> |
| 8. Alternator& Master switches: | <i>OFF</i> |



A single engine aircraft take off should always be preceded by a thorough take off emergency pilot self-briefing. Decision to try an engine emergency restart right after take off should be taken only if environmental situation requires it: pilot shall never ignore the priority of attentively follow an immediate emergency landing.

After possible mechanical engine seizure, fire or a major propeller damage, engine restart attempt is not recommended.

10.2 TRIM SYSTEM FAILURE

Trim Jamming

Should trim control be inoperative, act as follows:

1. Breaker: *CHECK IN*
2. LH/RH Trim switch: *CHECK for correct position*

If jamming persists

1. Trim cutout switch: *CHECK ON*
2. Speed: *adjust to control aircraft without excessive stick force*
3. **Land aircraft as soon as possible.**

Trim Runaway

In event of trim runaway, act as follows:

1. Trim cutout switch: *OFF*
2. Speed: *adjust to control aircraft without excessive stick force*
3. **Land aircraft as soon as possible.**

10.3 FLAPS FAILURE

In event of flaps-up landing, account for:

- Approach speed: *65 KIAS*
Landing length: *35% increased*

Supplement S7: pages replacement instructions

SECTION 4 – NORMAL PROCEDURES

Make sure you first applied instructions reported on the basic AFM and on the Supplements (if applicable), Section 4 Normal Procedures

According A/C configuration apply following pages replacement:

Supplement S7 pages		Basic AFM pages
WHN4-4	REPLACES	4-4

2. AIRSPEEDS FOR NORMAL OPERATIONS

The following airspeeds are those which are significant for normal operations.

	FLAPS	650kg
Rotation Speed (V_R)	T/O	50 KIAS
Flap Retraction Speed (V_{OBS})	TO	61 KIAS
Best Angle-of-Climb Speed (V_X)	0°	63 KIAS
Best Rate-of-Climb speed (V_Y)	0°	67 KIAS
Approach speed	T/O	61 KIAS
Final Approach Speed	FULL	55 KIAS
Optimal Touch Down Speed	FULL	55 KIAS
Manoeuvring speed (V_A)	0°	98 KIAS
Never Exceed Speed (V_{NE})	0°	143 KIAS

Supplement S7: pages replacement instructions

SECTION 5 – PERFORMANCE

**Make sure you first applied instructions reported on the basic AFM,
Section 5 Performance**

According A/C configuration apply following pages replacement:

Supplement S7 – Performance pages replace basic AFM Section 5 as a whole.

SECTION 5 – PERFORMANCE

1. INTRODUCTION	2
2. USE OF PERFORMANCE CHARTS	2
3. AIRSPEED INDICATOR SYSTEM CALIBRATION	3
4. ICAO STANDARD ATMOSPHERE.....	4
5. STALL SPEED.....	5
6. CROSSWIND.....	6
7. TAKE-OFF PERFORMANCE.....	7
8. TAKE-OFF RATE OF CLIMB	10
9. EN-ROUTE RATE OF CLIMB.....	11
10. CRUISE PERFORMANCE.....	12
11. LANDING PERFORMANCE	14
12. BALKED LANDING PERFORMANCE	15
13. NOISE DATA.....	15

1. INTRODUCTION

This section provides all necessary data for an accurate and comprehensive planning of flight activity from take-off to landing.

Data reported in graphs and/or in tables were determined using:

- ✓ “Flight Test Data” under conditions prescribed by EASA CS-VLA regulation
- ✓ aircraft and engine in good condition
- ✓ average piloting techniques

Each graph or table was determined according to ICAO Standard Atmosphere (ISA - s.l.); evaluations of the impact on performance were carried out by theoretical means for:

- ✓ Airspeed
- ✓ External temperature
- ✓ Altitude
- ✓ Weight
- ✓ Runway type and condition

2. USE OF PERFORMANCE CHARTS

Performance data are presented in tabular or graphical form to illustrate the effect of different variables such as altitude, temperature and weight. Given information is sufficient to plan the mission with required precision and safety.

Additional information is provided for each table or graph.

3. AIRSPEED INDICATOR SYSTEM CALIBRATION

Graph shows calibrated airspeed V_{IAS} as a function of indicated airspeed V_{CAS} .

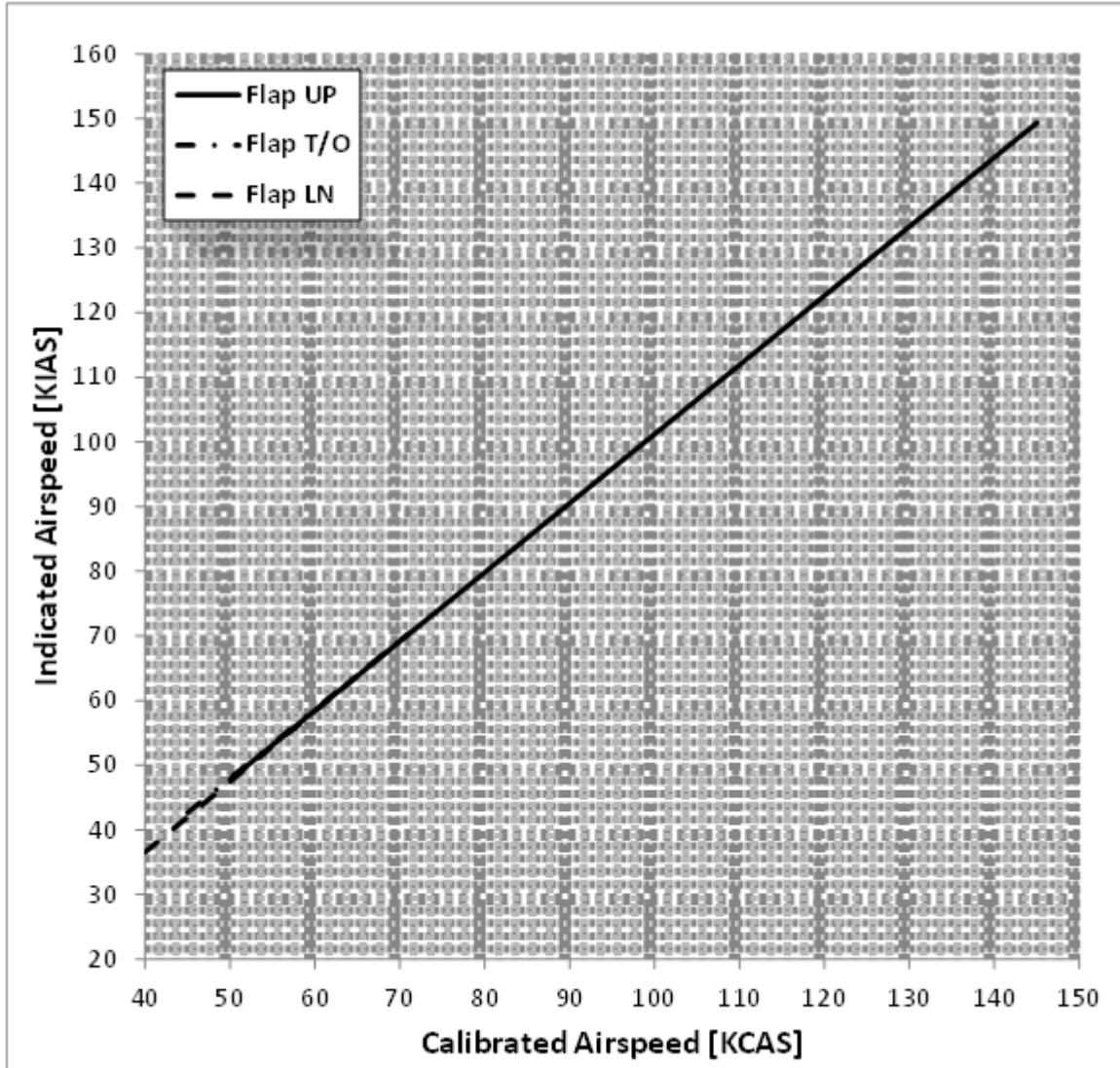

FIG. 5-1. CALIBRATED VS INDICATED AIRSPEED

Example:

Given

KIAS 75.0

Flap: UP

Find

KCAS 74.5

NOTE

Indicated airspeed assumes 0 as an instrument error

4. ICAO STANDARD ATMOSPHERE

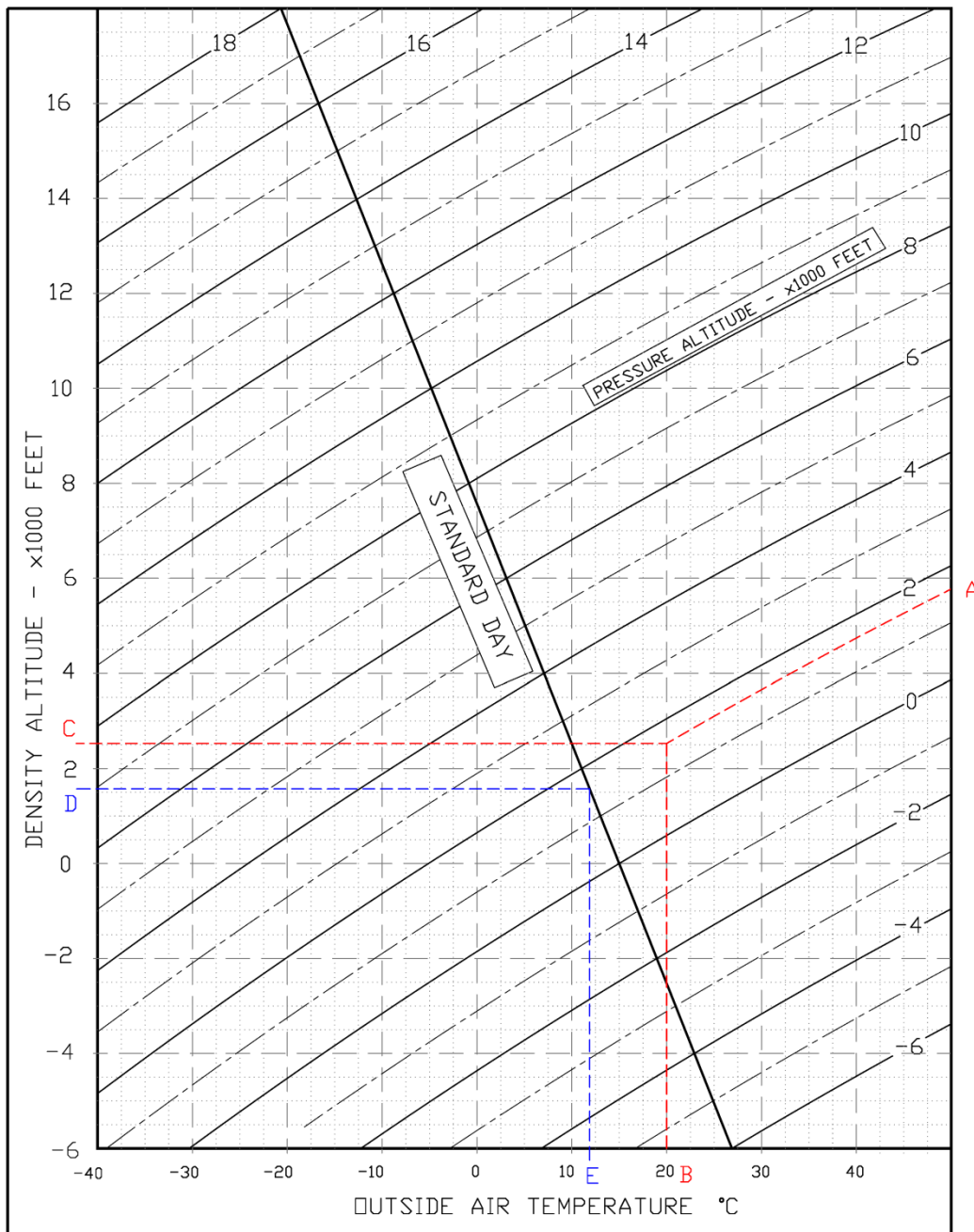

FIG. 5-2. ICAO CHART

Examples:

<u>Scope</u>	<u>Given</u>	<u>Find</u>
<u>Density Altitude:</u>	A: Pressure altitude = 1600ft B: Temperature = 20°C	→ C: Density Altitude = 2550ft
<u>ISA Temperature:</u>	D: Pressure altitude = 1600ft	→ E: ISA Air Temperature = 12°C

5. STALL SPEED

Weight: 650 kg Throttle Levers: IDLE CG: Most Forward (20%) No ground effect							
WEIGHT [kg]	BANK ANGLE [deg]	STALL SPEED					
		FLAPS 0°		FLAPS T/O		FLAPS FULL	
		KIAS	KCAS	KIAS	KCAS	KIAS	KCAS
650 (FWD C.G.)	0	49	51	46	48	40	44
	15	50	52	46	49	41	44
	30	53	55	49	51	44	47
	45	59	61	55	57	49	52
	60	71	72	67	67	60	62

NOTE

Altitude loss during conventional stall recovery, as demonstrated during flight tests is approximately 350 ft with banking below 30°.

6. CROSSWIND

Maximum demonstrated crosswind is 15Kts

⇒Example:

Given

Wind direction (with respect to aircraft longitudinal axis)= 30°

Wind speed = 20 Kts

Find

Headwind = 17.5 Kts

Crosswind = 10 Kts

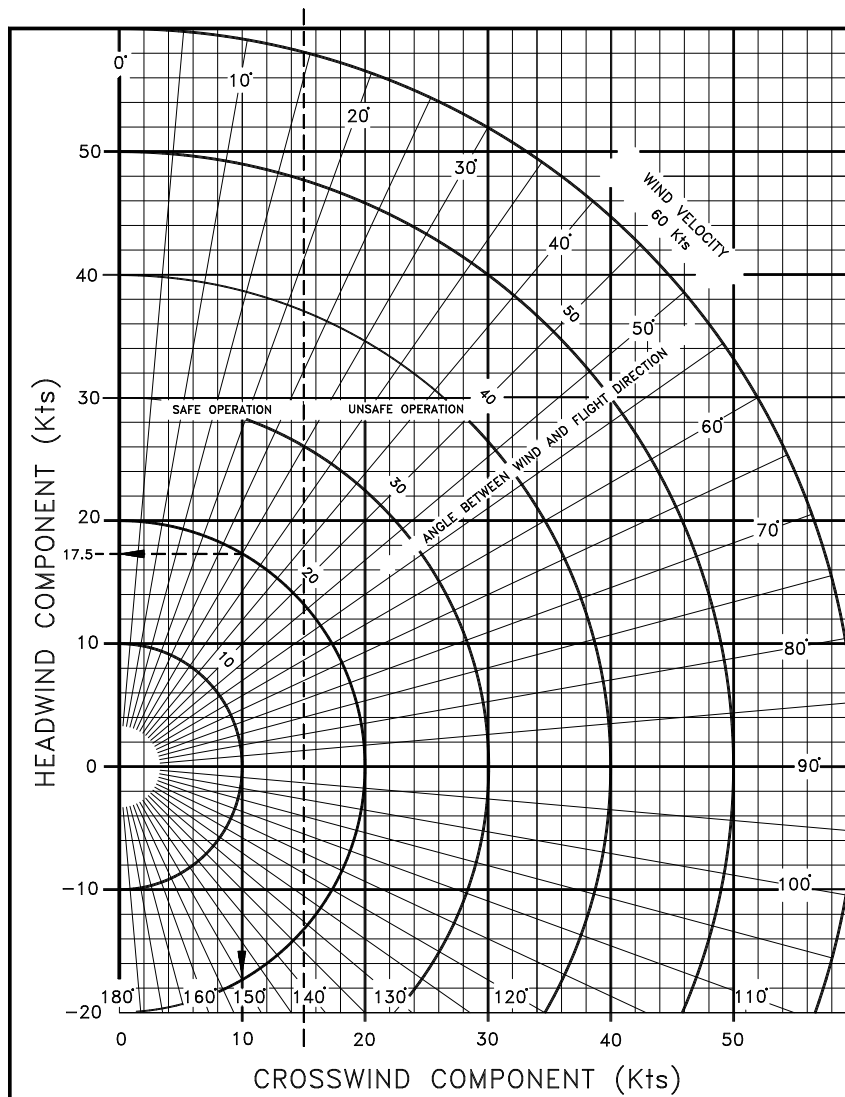

FIG. 5-2. CROSSWIND CHART

7. TAKE-OFF PERFORMANCE

NOTE

To account for likely in service performance variations apply a factored to distances of 1.10

Weight = 650 kg Flaps: T/O Speed at Lift-Off = 50 KIAS Speed Over 50ft Obstacle = 61 KIAS Throttle Levers: Full Forward Runway: Grass		Corrections Headwind: - 5 m for each kt (16 ft/kt) Tailwind: + 15 m for each kt (49 ft/kt) Paved Runway: - 10% to Ground Roll Runway slope: + 7% to Ground Roll for each +1%				
Pressure Altitude [ft]		Distance [m]				ISA
		Temperature [°C]				
		-25	0	25	50	
S.L.	Ground Roll	144	182	224	272	207
	At 50 ft AGL	304	379	463	557	428
1000	Ground Roll	157	198	245	297	222
	At 50 ft AGL	330	412	503	605	458
2000	Ground Roll	172	216	267	324	238
	At 50 ft AGL	359	448	547	658	490
3000	Ground Roll	188	236	292	354	256
	At 50 ft AGL	391	487	595	717	525
4000	Ground Roll	205	258	319	387	275
	At 50 ft AGL	425	530	648	780	562
5000	Ground Roll	224	283	349	423	295
	At 50 ft AGL	463	578	706	850	603
6000	Ground Roll	246	309	381	463	318
	At 50 ft AGL	505	630	770	927	646
7000	Ground Roll	269	339	418	507	342
	At 50 ft AGL	551	687	840	1011	693
8000	Ground Roll	295	371	458	555	368
	At 50 ft AGL	601	750	917	1104	744
9000	Ground Roll	323	407	502	609	397
	At 50 ft AGL	657	819	1002	1205	800
10000	Ground Roll	354	446	551	668	428
	At 50 ft AGL	718	895	1095	1318	859

Weight = 550 kg Flaps: T/O Speed at Lift-Off = 50 KIAS Speed Over 50ft Obstacle = 61 KIAS Throttle Levers: Full Forward Runway: Grass		Corrections Headwind: - 5 m for each kt (16 ft/kt) Tailwind: + 15 m for each kt (49 ft/kt) Paved Runway: - 10% to Ground Roll Runway slope: + 7% to Ground Roll for each +1%				
Pressure Altitude		Distance [m]				ISA
		Temperature [°C]				
[ft]		-25	0	25	50	
S.L.	Ground Roll	97	122	150	182	138
	At 50 ft AGL	207	258	316	380	292
1000	Ground Roll	105	133	164	199	148
	At 50 ft AGL	225	280	343	413	312
2000	Ground Roll	115	145	179	217	159
	At 50 ft AGL	245	305	373	449	334
3000	Ground Roll	126	158	195	237	171
	At 50 ft AGL	266	332	406	488	358
4000	Ground Roll	137	173	213	259	184
	At 50 ft AGL	290	361	442	531	383
5000	Ground Roll	150	189	233	283	198
	At 50 ft AGL	316	394	481	579	411
6000	Ground Roll	164	207	255	310	213
	At 50 ft AGL	344	429	525	631	440
7000	Ground Roll	180	227	280	339	229
	At 50 ft AGL	375	468	572	689	472
8000	Ground Roll	197	248	307	372	247
	At 50 ft AGL	410	511	625	752	507
9000	Ground Roll	216	272	336	408	266
	At 50 ft AGL	447	558	682	821	545
10000	Ground Roll	237	299	369	447	286
	At 50 ft AGL	489	610	746	897	585

Weight = 450 kg Flaps: T/O Speed at Lift-Off = 50 KIAS Speed Over 50ft Obstacle = 61 KIAS Throttle Levers: Full Forward Runway: Grass		Corrections Headwind: - 5 m for each kt (16 ft/kt) Tailwind: + 15 m for each kt (49 ft/kt) Paved Runway: - 10% to Ground Roll Runway slope: + 7% to Ground Roll for each +1%				
Pressure Altitude		Distance [m]				ISA
		Temperature [°C]				
[ft]		-25	0	25	50	
S.L.	Ground Roll	60	75	93	113	85
	At 50 ft AGL	131	163	199	239	184
1000	Ground Roll	65	82	101	123	92
	At 50 ft AGL	142	177	216	260	197
2000	Ground Roll	71	90	110	134	98
	At 50 ft AGL	154	192	235	283	211
3000	Ground Roll	78	98	121	146	106
	At 50 ft AGL	168	209	256	308	226
4000	Ground Roll	85	107	132	160	114
	At 50 ft AGL	183	228	279	335	242
5000	Ground Roll	93	117	144	175	122
	At 50 ft AGL	199	248	304	365	259
6000	Ground Roll	102	128	158	191	131
	At 50 ft AGL	217	271	331	398	278
7000	Ground Roll	111	140	173	210	141
	At 50 ft AGL	237	295	361	434	298
8000	Ground Roll	122	153	189	230	152
	At 50 ft AGL	258	322	394	474	320
9000	Ground Roll	134	168	208	252	164
	At 50 ft AGL	282	352	430	518	344
10000	Ground Roll	147	185	228	276	177
	At 50 ft AGL	308	384	470	566	369

8. TAKE-OFF RATE OF CLIMB

NOTE

To account for likely in service performance variations apply a factored to rate of climb of 0.90

Throttle Levers: Full Forward							
Flaps: Take Off (15°)							
Weight	Pressure Altitude	Climb Speed V_y	Rate of Climb [ft/min]				ISA
			Temperature [°C]				
[kg]	[ft]	[KIAS]	-25	0	25	50	
650	S.L.	70	951	805	675	557	725
	2000	69	840	696	568	453	638
	4000	68	729	588	462	349	551
	6000	67	619	480	357	245	464
	8000	65	509	373	251	142	377
	10000	64	399	266	146	39	290
	12000	63	290	159	42	-64	204
	14000	62	181	53	-63	-166	117
600	S.L.	70	1067	913	776	652	829
	2000	68	950	799	664	542	737
	4000	67	833	685	552	433	646
	6000	66	717	571	441	324	555
	8000	65	602	458	330	215	463
	10000	64	486	345	220	106	372
	12000	63	371	233	110	-2	280
	14000	62	257	121	0	-109	189
550	S.L.	69	1201	1038	892	760	948
	2000	68	1077	916	773	644	851
	4000	67	953	795	654	527	754
	6000	66	830	675	536	411	657
	8000	65	707	555	419	296	560
	10000	64	584	435	301	181	462
	12000	63	462	315	184	66	365
	14000	61	341	196	68	-48	268

9. EN-ROUTE RATE OF CLIMB

NOTE

To account for likely in service performance variations apply a factored to rate of climb of 0.90

Throttle Levers: Full Forward							
Flaps: UP							
Weight	Pressure Altitude	Climb Speed V_Y	Rate of Climb [ft/min]				ISA
			Temperature [°C]				
[kg]	[ft]	[KIAS]	-25	0	25	50	
650	S.L.	67	981	835	704	586	755
	2000	67	870	726	597	481	667
	4000	67	759	617	491	377	580
	6000	67	648	509	385	273	493
	8000	67	538	401	279	170	406
	10000	67	428	294	174	66	319
	12000	67	319	187	69	-37	232
	14000	67	210	80	-35	-139	145
600	S.L.	67	1104	948	809	683	863
	2000	67	985	832	695	572	770
	4000	67	867	717	582	461	677
	6000	67	750	602	470	351	585
	8000	67	632	487	357	240	492
	10000	66	515	373	245	131	399
	12000	66	399	259	134	21	307
	14000	66	283	145	23	-88	214
550	S.L.	67	1245	1078	929	794	987
	2000	67	1118	954	807	675	887
	4000	67	992	830	686	556	788
	6000	66	865	707	565	438	688
	8000	66	740	584	445	319	589
	10000	66	614	461	325	202	490
	12000	66	489	339	205	84	390
	14000	66	365	218	86	-33	291

10. CRUISE PERFORMANCE



Propeller speed over 2265 RPM is restricted to 5min.

Weight = 650 kg							
CORRECTIONS							
	KTAS	Fuel Consumption	Endurance	Range	Specific Range		
For each +15°C of OAT	-2%	-2.5%	+2%	+1%	+1%		
For each -15°C of OAT	+1%	+3%	-4%	-2%	-1%		
For -100kg of weight	+3.3%	-	-	+3%	+4%		
CRUISE PERFORMANCE							
Pressure Altitude [ft]	OAT ISA [deg C]	Propeller RPM	KTAS	Fuel Consumption [lt/hr]	Endurance [hr:mm]	Range [nm]	Specific Range [nm/lt]
0	15	2388	118	26.9	4:28	526	4.4
		2250	110	24.6	4:53	537	4.5
		2100	101	20.7	5:48	586	4.9
		2000	95	18.7	6:25	610	5.1
		1900	89	17	7:04	628	5.2
		1800	83	15.6	7:42	639	5.3
2000	11	2250	109	23.5	5:06	557	4.6
		2100	100	19.9	6:02	603	5.0
		2000	94	18.1	6:38	623	5.2
		1900	88	16.6	7:14	636	5.3
		1800	82	15.3	7:51	643	5.4

Weight = 650 kg							
CORRECTIONS							
	KTAS	Fuel Consumption	Endurance	Range	Specific Range		
For each +15°C of OAT	-2%	-2.5%	+2%	+1%	+1%		
For each -15°C of OAT	+1%	+3%	-4%	-2%	-1%		
For -100kg of weight	+3.3%	-	-	+3%	+4%		
CRUISE PERFORMANCE							
Pressure Altitude [ft]	OAT ISA [deg C]	Propeller RPM	KTAS	Fuel Consumption [lt/hr]	Endurance [hr:mm]	Range [nm]	Specific Range [nm/lt]
4000	7	2250	108	22.4	5:21	579	4.8
		2100	100	19.2	6:15	625	5.2
		2000	94	17.5	6:51	645	5.4
		1900	88	16.2	7:24	652	5.4
		1800	82	15.1	7:57	652	5.4
6000	3	2250	108	21.3	5:38	609	5.1
		2100	99	18.5	6:29	642	5.4
		2000	93	17.1	7:01	653	5.4
		1900	87	15.9	7:33	657	5.5
		1800	81	14.9	8:03	652	5.4
8000	-1	2250	107	20.4	5:53	629	5.3
		2100	98	18	6:40	653	5.4
		2000	92	16.7	7:11	661	5.5
		1900	86	15.6	7:42	662	5.5
10000	-5	2250	106	19.7	6:05	646	5.4
		2100	97	17.5	6:51	665	5.5
		2000	91	16.4	7:19	666	5.6
		1900	85	15.4	7:48	662	5.5

11. LANDING PERFORMANCE

NOTE

To account for likely in service performance variations apply a factored to distances of 1.67

Weight = 650 kg		Corrections				
Flaps: LAND		Headwind: -4m for each kt (13 ft/kt)				
Short Final Approach Speed = 54 KIAS		Tailwind: + 13m for each kt (43 ft/kt)				
Throttle Levers: Idle		Paved Runway:-10% to Ground Roll				
Runway: Grass		Runway slope: -3% to Ground Roll for each +1%				
Pressure Altitude [ft]		Distance [m]				
		Temperature [°C]				ISA
		-25	0	25	50	
S.L.	Ground Roll	149	164	179	194	173
	At 50 ft AGL	358	373	388	403	382
1000	Ground Roll	154	170	186	201	178
	At 50 ft AGL	363	379	395	410	387
2000	Ground Roll	160	176	192	209	183
	At 50 ft AGL	369	385	401	418	392
3000	Ground Roll	166	183	200	216	189
	At 50 ft AGL	375	392	409	425	398
4000	Ground Roll	172	190	207	225	195
	At 50 ft AGL	381	399	416	434	404
5000	Ground Roll	179	197	215	233	201
	At 50 ft AGL	388	406	424	442	410
6000	Ground Roll	186	205	223	242	207
	At 50 ft AGL	395	414	432	451	416
7000	Ground Roll	193	212	232	251	213
	At 50 ft AGL	402	421	441	460	422
8000	Ground Roll	200	221	241	261	220
	At 50 ft AGL	410	430	450	470	429
9000	Ground Roll	208	229	250	271	227
	At 50 ft AGL	417	438	459	480	436
10000	Ground Roll	217	238	260	282	234
	At 50 ft AGL	426	447	469	491	443

12. BALKED LANDING PERFORMANCE

NOTE

To account for likely in service performance variations apply a factored to rate of climb and to angle of climb of 0.90

Throttle Levers: Full Forward						
Flaps: LAND						
Speed: 54 KIAS						
Weight	Pressure Altitude	Angle of Climb [deg]				ISA
		Temperature [°C]				
[kg]	[ft]	-25	0	25	50	
650	S.L.	8.4	7.0	5.8	4.7	6.3
	2000	7.4	6.0	4.8	3.7	5.5
	4000	6.3	5.0	3.8	2.7	4.6
	6000	5.3	3.9	2.8	1.7	3.8
	8000	4.2	2.9	1.8	0.7	3.0
	10000	3.2	1.9	0.8	-0.3	2.1
	12000	2.1	0.9	-0.2	-1.2	1.3
	14000	1.1	-0.1	-1.2	-2.2	0.5

13. NOISE DATA

Noise level, determined in accordance with ICAO/Annex 16 6th Ed., July 2011, Vol. I°, Chapter 10, is **68.78dB(A)**.

INTENTIONALLY LEFT BLANK

Supplement S7: pages replacement instructions

SECTION 6 – WEIGHT AND BALANCE

**Make sure you first applied instructions reported on the basic AFM,
Section 6 Weight and Balance**

According A/C configuration apply following pages replacement:

Supplement S7 WEIGHT AND BALANCE page		AFM Section 6 page
WH6-5 thru 6	REPLACES	Page 6-5 thru 6 of basic AFM, Section 6
WH6-9	REPLACES	Page 6-9 of basic AFM, Section 6

2.5. WEIGHING RECORD

Model **P2008 JCS**/N: _____ Weighing no. _____ Date: _____

Datum: Propeller Flange

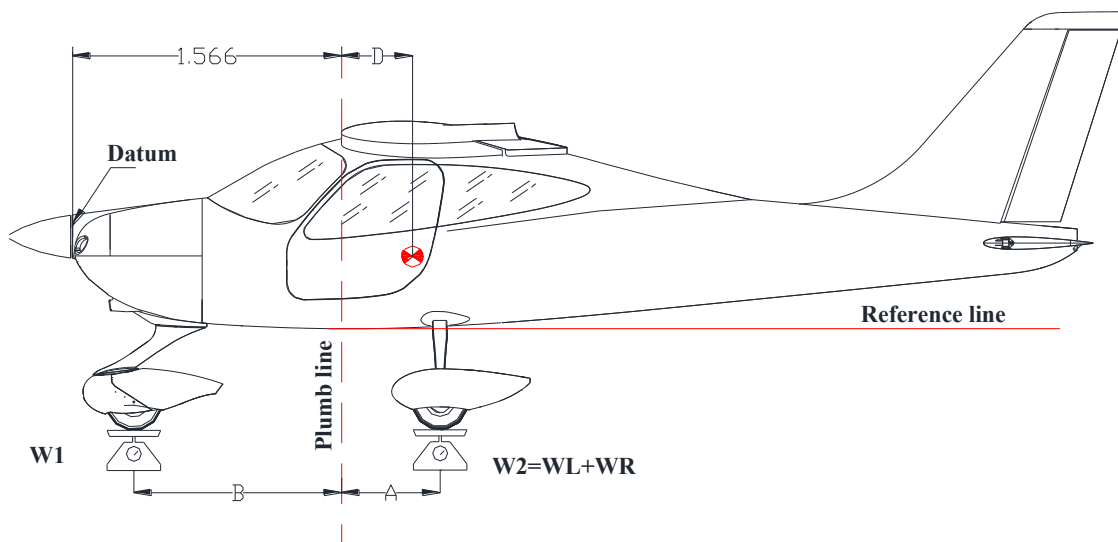

	<i>Kg or Lbs</i>		<i>Meters or feet</i>
Nose wheel weight	$W_1 =$	Plumb bob distance LH wheel	$A_L =$
LH wheel weight	$W_L =$	Plumb bob distance RH wheel	$A_R =$
RH wheel weight	$W_R =$	Average distance $(A_L + A_R)/2$	$A =$
$W_2 = W_L + W_R =$		Plumb bob distance from nose wheel	$B =$

Empty weight $W_e = W_1 + W_2 =$ [kg] or [lbs]

$D = \frac{W_2 \cdot A - W_1 \cdot B}{W_e}$ [m] or [Ft] $D\% = \frac{D}{1.373 \text{ m (or 4.5 ft)}} \cdot 100 =$

Empty weight moment: $M = [(D+1.566) \cdot W_e] =$ [m · kg] or [ft · lbs]

Maximum takeoff weight	$W_T = 650 \text{ kg}$ (1433 lbs)	Signature _____ _____
Empty weight	$W_e =$ [kg] or [lbs]	
Max. useful load $W_T - W_e$	$W_u =$ [kg] or [lbs]	

2.6. WEIGHING RECORD (II)

Model **P2008 JCS/N:** _____ Weighing no. _____ Date: _____

Datum: Propeller Flange

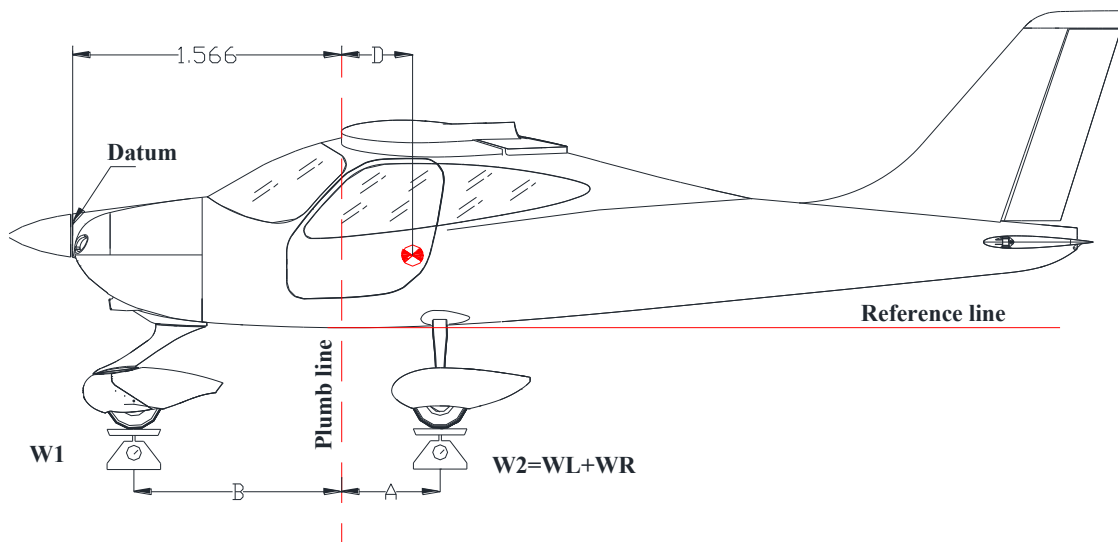

	<i>Kg or Lbs</i>		<i>Meters or feet</i>
Nose wheel weight	$W_1 =$	Plumb bob distance LH wheel	$A_L =$
LH wheel weight	$W_L =$	Plumb bob distance RH wheel	$A_R =$
RH wheel weight	$W_R =$	Average distance $(A_L + A_R)/2$	$A =$
$W_2 = W_L + W_R =$		Plumb bob distance from nose wheel	$B =$

Empty weight $W_e = W_1 + W_2 =$ [kg] or [lbs]

$D = \frac{W_2 \cdot A - W_1 \cdot B}{W_e} =$ [m] or [ft] $D\% = \frac{D}{1.373 \text{ m (or 4.5 ft)}} \cdot 100 =$

Empty weight moment: $M = [(D+1.566) \cdot W_e] =$ [m · kg] or [ft · lbs]

Maximum takeoff weight	$W_T = 650 \text{ kg}$ (1433 lbs)	Signature _____ _____
Empty weight	$W_e =$ [kg] or [lbs]	
Max. useful load $W_T - W_e$	$W_u =$ [kg] or [lbs]	

C.G.Range	Max FWD	Max AFT
Meters	1.841	1.978
Max Weight	Pounds	Kilograms
	1433.00	650.00

Example						
	Weight		Arm		Moment	
	lbs	kg	in	m	lbs in	kg m
Empty	813.5	369.0	74.4	1.89	60533	697.4
Fuel	150.0	68.0	87.0	2.21	13052	150.4
Pax	300.0	136.1	70.9	1.80	21270	245.1
Baggage	0	0	94.9	2.41	0	0
Total	1263.5	573.1	75.1	1.91	94854	1092.8

In this example, the gross weight is under the max gross weight and the Arm or C.G. is within the C.G. range listed above.

4. BAGGAGE LOADING

The baggage loading in the dedicated compartment, behind the pilots' seats, must be carried out in accordance with C.G. excursion and weight limitations reported in Section 2.

Baggage must be uniformly distributed on compartment floor.

Pilot is provided with a red tie-down net and snap fasteners allowing for securing the loads on the compartment floor.



CAUTION

Loading the baggage, make sure that you correctly stretched the net which must be secured to the four vertices of the compartment.

Supplement S7: pages replacement instructions

SECTION 7 – AIRFRAME AND SYSTEMS DESCRIPTION

Make sure you first applied instructions reported on the basic AFM,
Section 7 Airframe and Systems Description

Apply following pages replacement:

Supplement S7 AIRFRAME AND SYS- TEMS DESCRIPTION page		AFM Section 7 page
WH7-10	REPLACES	Page 7-10 of basic AFM, Section 7

7. POWERPLANT

7.1. ENGINE

Manufacturer:	<i>Bombardier-Rotax GmbH</i>
Model:	<i>ROTAX 912 S2</i>
Type:	<i>4 stroke, horizontally-opposed 4 cylinder, mixed air and water cooled, twin electronic ignition, forced lubrication.</i>
Maximum rating:	<i>98.6hp (73.5kW) @ 5800 rpm/min (2388 rpm/min. prop). Gear reduction ratio - 2.4286:1</i>
Max oil consumption:	<i>Max: 0.1 litres/hour</i>

7.2. PROPELLER

Manufacturer:	<i>Hoffman Propellers</i>
Model:	<i>HO17GHM A 174 177C</i>
N° of blades:	<i>2</i>
Diameter:	<i>1740 mm</i>
Type:	<i>fixed pitch</i>

Supplement S7: pages replacement instructions

SECTION 8 – GROUND HANDLING & SERVICE

**Make sure you first applied instructions reported on the basic AFM,
Section 8 Ground Handling & Service**

Refer to the basic AFM, Section 8 – Ground Handling & Service.

Supplement no. S8

AFMS FOR MD302 and GARMIN G3X Touch

Record of Revisions

Rev	Revised page	Description of Revision	Tecnam Approval			EASA Approval or Under DOA Privileges
			DO	OoA	HDO	
0	All	Editorial revision	A. Sabino	C. Caruso	M. Oliva	EASA Approval 10064044
1	MW2-6, M4-15, MAN4-15, MH4-3, MH4-15, MHAN4-15, MW4-3, MW4-15, MWAN4-15, MWH4-3, MWH4-15, MWHAN4-15, MAN7-6, MAN7-7	Pages removed; information integrated in basic AFM.	A. Sabino	C. Caruso	M. Oliva	Approved under the authority of DOA, ref. EASA.21J.335 (MOD2008/103.180312)
	All cover pages	Updated				
	M4-3	Paragraph removed as per basic AFM change				
	M7-6, 7	Paragraphs shifted to match basic AFM arrangement.				
2	S8-1, M7-13	MOD2008/100	A. Sabino	D. Ronca	M. Oliva	Approved under the authority of DOA, ref. EASA.21J.335 (MOD2008/100.190614)
3	S8-1, M2-21, MW2-21, M2-28	Typo on placard position	G.Valentino	D. Ronca	M. Oliva	Approved under the authority of DOA, ref. EASA.21J.335 (MOD2008/143.200730)
4	S8-1, M2-19, M2-28	Warning optimization	G.Valentino	D. Ronca	M. Oliva	Approved under the authority of DOA, ref. EASA.21J.335 (MOD2008/144.201022)
5	S8-1, M2-28 S8-5	Typo error	L.De Salvi	D. Ronca	M. Oliva	Approved under the authority of DOA, ref. EASA.21J.335 (MOD2008/188.230126)
6	S8-1, M4-3	Normal procedures optimization	G.Valentino	D. Ronca	M. Oliva	Approved under the authority of DOA, ref. EASA.21J.335 (MOD2008/199.230605)
	M2-19	MOD2008/182				
7	S8-1, M7-13	MOD2008/239	F. Losappio	D. Ronca	M. Oliva	Approved under the authority of DOA, ref. EASA.21J.335 (MOD2008/239.250630)

List of Effective Pages

	Page	Revision
Cover Pages	S8-2 thru 4, S8-6 thru 8	Rev 1
	S8-5	Rev 5
	S8-1	Rev 7
Section 2	M2-20, 22,	Rev 0
	M2-21, MW2-21	Rev 3
	M2-28	Rev 5
	M2-19	Rev. 6
Section 3	M3-6	Rev 0
Section 4	M4-3	Rev 6
Section 7	M7-6 thru 8, M7-12, M7-15	Rev 0
	M7-13	Rev 7

INDEX

INDEX	2
INTRODUCTION	3
Section 1 – GENERAL	4
Section 2 – LIMITATIONS	5
Section 3 – EMERGENCY PROCEDURES.....	6
Section 4 – NORMAL PROCEDURES	7
Section 7 – AIRFRAME AND SYSTEMS DESCRIPTION	8

INTRODUCTION

The information contained herein supplements or supersedes the basic Aircraft Flight Manual embodying Supplements S1.

It is the owner's responsibility to replace the mentioned pages in accordance with the instructions herein addressed section by section.

Supplement S8: pages replacement instructions

SECTION 1 – GENERAL

**Make sure you first applied instructions reported on the basic AFM,
Section 1 General**

Refer to the basic AFM, Section 1 – General.

Supplement S8: pages replacement instructions

SECTION 2 – LIMITATIONS

**Make sure you first applied instructions reported on Supplement S1,
Section 2 – Limitations**

According A/C configuration apply following pages replacement:

Supplement S8 pages		Basic AFM pages	Supplement S1 pages	Supplement S2 pages	Supplement S4 pages	Supplement S7 pages
M2-19	REPLACES	2-19	2N-19	2AN-19	/	/
M2-20	REPLACES	2-20	2N-20	2AN-20	/	/
M2-21	REPLACES	2-21	2N-21	/	/	/
MW2-21	REPLACES	/	/	/	2WN-21	WHN2-21
M2-22	REPLACES	2-22	2N-22	/	/	/
M2-28	REPLACES	2-28	2N-28	/	/	/

20. KINDS OF OPERATION EQUIPMENT LIST (KOEL)

This paragraph reports the KOEL table, concerning the equipment list required on board under CS-VLA regulations to allow flight operations in VFR Day and VFR Night.

Flight in VFR Day and Night is permitted only if the prescribed equipment is installed and operational.



For aircraft NOT embodying MOD2008/038 (Aveo Maxx Landing/Taxi lights) or MOD2008/182 (PAR36 Landing Taxi light installation), VFR NIGHT operation is limited to airfields providing centre line illumination.

Additional equipment, or a different equipment list, for the intended operation may be required by national operational requirements and also depends on the airspace classification and route to be flown. The owner is responsible for fulfilling these requirements.



Primary flight information (airspeed, altitude, heading and attitude) is provided by MD302. All information provided by G3X Touch is only intended for situational awareness.

AFMS S8 - MD302 and G3X Touch

Equipment	VFR Day	VFR Night
MD302 (PFI)	•	•
MAGNETIC DIRECTION INDICATOR	•	•
ANALOGUE FUEL QUANTITY INDICATORS	•	•
ANALOGUE CT (or CHT if applicable) INDICATOR	•	•
ANALOGUE RPM INDICATOR	•	•
ANALOGUE OIL TEMPERATURE INDICATOR	•	•
ANALOGUE VOLTMETER	•	•
GARMIN 3X TOUCH SUITE		
TRANSPONDER	•	•
ALTITUDE ENCODER	•	•
LONGITUDINAL TRIM INDICATOR	•	•
FLAP POSITION INDICATOR	•	•
COMM/NAV EQUIPMENT	•	•
AUDIO PANEL/MARKER BEACON	•	•
LANDING/TAXI LIGHT		•
STROBE LIGHTS		•
NAV LIGHTS		•
ANNUNCIATOR PANEL	•	•
BREAKERS PANEL	•	•
STALL WARNING SYSTEM	•	•
FIRST AID KIT	•	•
HAND-HELD FIRE EXTINGUISHER	•	•
ELT	•	•
PITOT HEAT		•
TORCH (WITH SPARE BATTERIES)		•
PANEL LIGHTS		•
EMERGENCY LIGHT		•
DIMMING DEVICES		•
DAY/NIGHT SWITCH		•

21. LIMITATIONS PLACARDS

The following limitation placards are placed in plain view of the pilot.

Manoeuvring Speed
V_A = 99 kts

This a/c is classified as VLA
approved for
DAY OR NIGHT VFR
(with required equipment)
in non-icing conditions.
all aerobatics manoeuvres
including spinning are prohibited.
For operating limitations
refer to KOEL in the
FLIGHT MANUAL

On the right hand side of the instrument panel the following placard is placed reminding the observance for “no smoking”:

NO SMOKING

In the baggage compartment following placard is placed:

TIE-DOWN HARNESS
MAX WEIGHT 20kg [44 lbs]

DO NOT PLACE SHARP
OBJECTS ON THE FLOOR

21. LIMITATIONS PLACARDS

The following limitation placards are placed in plain view of the pilot.

Manoeuvring Speed
 $V_A = 98$ kts

This a/c is classified as VLA
approved for
DAY OR NIGHT VFR
(with required equipment)
in non-icing conditions.
all aerobatics manoeuvres
including spinning are prohibited.
For operating limitations
refer to KOEL in the
FLIGHT MANUAL

On the right hand side of the instrument panel the following placard is placed reminding the observance for “no smoking”:

NO SMOKING

In the baggage compartment following placard is placed:

TIE-DOWN HARNESS
MAX WEIGHT 20kg [44 lbs]

DO NOT PLACE SHARP
OBJECTS ON THE FLOOR

Below the G3X Touch LH screen, the following label is placed:

FOR SITUATIONAL AWARENESS ONLY

Upper panel

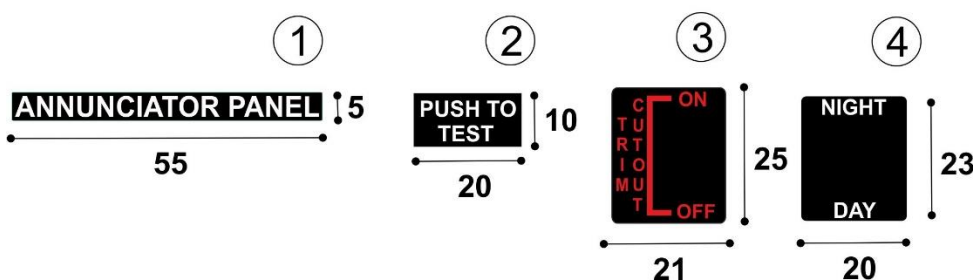
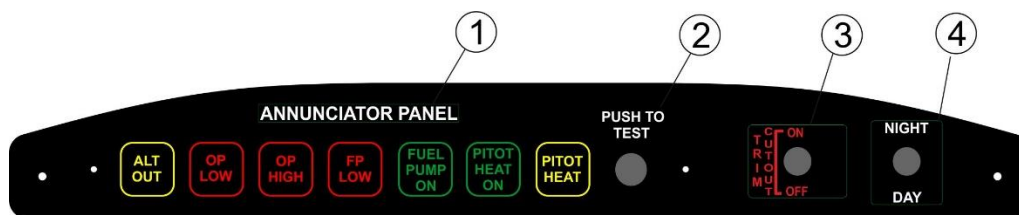

Switches labels



Door lock lever

CLOSED

OPEN

Supplement S8: pages replacement instructions

SECTION 3 – EMERGENCY PROCEDURES

**Make sure you first applied instructions reported on Supplement S1
Section 3 – Emergency Procedures**

According A/C configuration apply following pages replacement:

Supplement S8 pages		Basic AFM pages	Supplement S1 pages
M3-6	REPLACES	3-6	3N-6

2.2. G3X TOUCH FAILURES

In case of LH or RH display failure, navigation and engine data will be automatically available in the remaining display (split mode).



INSTRUCTION: revert to the remaining display.



Garmin G3X is NOT intended to be used as primary reference for flight and navigation information but only provides information for increased situational awareness. Primary flight information (altitude, airspeed, attitude and slip/skid indication) is provided by MD302.

Supplement S8: pages replacement instructions

SECTION 4 – NORMAL PROCEDURES

**Make sure you first applied instructions reported on the basic AFM,
Section 4 – Normal Procedures**

According A/C configuration apply following pages replacement:

Supplement S8 pages		Supplement S1 page
M4-3	REPLACES	4N-3

1. INTRODUCTION

Section 4 describes checklists and recommended procedures for the conduct of normal operations for *P2008 JC* aircraft.



WARNING

Garmin G3X indeed is NOT intended to be used as primary reference for flight and navigation information but only provides information for increased situational awareness. Primary flight information (altitude, airspeed, attitude and slip/skid indication) is provided by MD302.

NOTE

Wearing ear plugs as well as the use of noise canceling systems can somehow decrease the ability to adequately perceive audio alerts.

Supplement S8: pages replacement instructions

SECTION 7 – AIRFRAME AND SYSTEMS DESCRIPTION

Make sure you first applied instructions reported on the basic AFM,
Section 7 – Airframe And Systems Description

According A/C configuration apply following pages replacement:

Supplement S8 pages		Basic AFM pages	Supplement S1 pages	Supplement S2 pages
M7-6	REPLACES	7-6	7N-6	7AN-6
M7-7	REPLACES	7-7	7N-7	7AN-7
M7-8	REPLACES	7-8	7N-8	/
M7-12	REPLACES	7-12	/	/
M7-13	REPLACES	7-13	7N-13	/
M7-15	REPLACES	7-15	/	/

4. INSTRUMENT PANEL

The instrument panel is divided in five areas.

- The main area holds
 - primary flight information instruments (MD302)
 - pilot's situational awareness instruments (G3X Touch)
 - ELT switch
 - trim LH/RH pilot's switch selector
 - pitch trim indicator
 - chronometer
 - ignition key
 - master and generator switches
 - engine instruments (Oil Temp., RPM, CT/CHT, Voltmeter)
 - breakers panel
 - two fuel indicators
- The upper area holds
 - stabilator trim cut out switch
 - day/night switch (selecting between two brightness levels for warning lights in the annunciator panel)
 - annunciator panel, with the following indications
 - ALT OUT..... (AMBER)
 - OP LOW..... (RED)
 - OP HIGH..... (RED)
 - FP LOW..... (RED)
 - FUEL PUMP ON..... (GREEN)
 - PITOT HEAT ON..... (GREEN)
 - PITOT HEAT..... (AMBER)
- The left section of the lower bezel holds
 - ignition key
 - emergency fuel pump switch
 - avionic Master switch
 - pitot heat switch
 - emergency light switch
 - carburetor heat knob
- The right section of the lower bezel holds
 - dimming devices
 - NAV, land and strobe lights switches
 - Taxi light (if installed)
- The central column holds
 - audio Panel
 - COM/NAV Panel
 - transponder
 - fuel tank selector
 - flap indicator and toggle switch
 - throttle



Fig. 7-5. INSTRUMENT PANEL

4.1. CARBURETTOR HEAT

Carburettor heat control knob is located lower-LH portion of the instrument panel; when the knob is pulled fully outward from the instrument panel, carburetors receive maximum hot air. During normal operation, the knob is set in OFF position.

4.2. CABIN HEAT

The cabin heat control knob is positioned on the lower right side of the instrument panel; when knob is pulled fully outward, cabin receives maximum hot air. If the outlets are kept closed, hot air only performs windshield defrost. Vents are located by the rudder pedals. If necessary, outside fresh air can be circulated inside cabin by opening the vents on the doors' windows.

4.3. INTERNAL LIGHTS SYSTEM

An internal lights system is provided; it's based on the following elements:

- LH light for
 - Pitch trim indicator
 - LH/RH trim switch
 - Master switch
 - Generator switch
 - Ignition
- Central light for
 - Fuel tank selector
 - ELT switch
- RH light for breaker panel
- MAP Light
- Emergency light

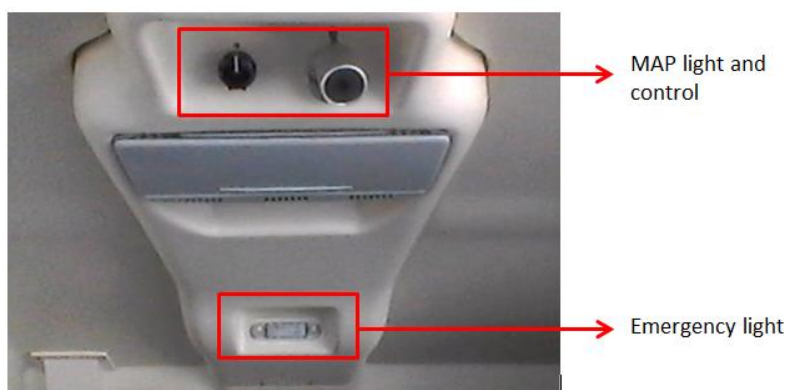

9. ELECTRICAL SYSTEM

Primary DC power is provided by an external alternator with a 14 VDC output, rated to 40 Amps @ 5800 rpm. During normal operations, it recharges the batteries. Secondary DC power is provided by a main battery which provides the energy necessary for feeding the essential electrical loads in the event of an alternator failure.

In order to avoid the shut-down of G3X Touch during engine start-up, which is the most demanding phase in terms of current absorption, a 2 Ah valve regulated lead-acid buffer battery is installed.

This secondary battery can also provide additional electrical power in the event of an alternator failure or a total loss of electrical system. This battery is enabled by the master switch and is only connected to the G3X Touch units. It is installed beside the main battery and is housed in a dedicated box.

The switch between the energy sources (alternator and main battery) is automatic and no action is required in order to activate the alternate energy source.

For ground maintenance and/or starting, an external power socket is provided.

The alternator and battery are connected to the battery bus in order to provide energy for the electric equipment.

Each electrically fed instrument is connected to a dedicated circuit breaker which protects the cable from the battery bus to the associated electric equipment.



If the Ignition is in the position L, R, or BOTH, an accidental movement of the propeller may start the engine with possible danger for bystanders.

9.1. STALL WARNING SYSTEM

The aircraft is equipped with a stall warning system consisting of a sensor located on the right wing leading edge connected to a warning horn located near the instrument panel.

9.2. AVIONICS

The avionic system installed P2008 JC is based on MD302, which provides primary flight information. It is located in the centre of the instrument panel.

On the right side of the instrument panel, analogue indicators provide primary information of engine parameters, (RPM, oil temperature and CT/CHT).

Below engine instruments, a dedicated analogue voltmeter, which provides primary information of the electrical power supplied, and two analogue fuel quantity indicators are installed.

Garmin G3X Touch integrated avionic suite is installed. It provides flight and engine information intended for the pilot's situational awareness only.

G3X also embodies a GPS WAAS receiver whose information, intended for situational awareness only, are presented on RH display moving map.

Two dedicated indicators provide the pilot with information about the flaps and pitch trim position.

Stand-alone external COM/NAV and transponder sources (Garmin GNC 255A, or Garmin GNC 215, and GTX 335) are installed. Garmin GNC 255A, or Garmin GNC 215, navigation information is presented on the display (course and direction) along with the information related to active/standby frequency. This information is supplemented by an HSI indicator on G3X Touch LH display.

GTX 335 transponder provides SSR (Secondary Surveillance Radar) responses; this unit is capable of both mode "S" and mode "C". An external altitude encoder (ACK A-30) allows altitude reporting, this information is also presented on GTX 335 display. An automatic reversion mode is integrated within the system in order to continue providing the pilot with the flight and engine information in the event of a LH or RH display failure.

Optional equipment:

KN63 DME System

The system is composed by the KN63 (DME Receiver), KDI572 (DME Indicator) and CI105-16 (DME Antenna).

KR87 ADF System

The system is composed by the KR87 (ADF Receiver), KI227 (ADF Indicator), KA44B (ADF Antenna).

10. PITOT-STATIC PRESSURE SYSTEMS

The P2008 JC air speed/altitude indicating systems are connected with a Pitot-Static system based on a total pressure/Pitot probe (Heated Pitot tube) mounted under left wing and two static pressure ports connected in parallel and located in correspondence of engine firewall on left and right side of fuselage. Flexible plumbing connects total pressure and static ports to primary instruments. An alternate static source is located in the cabin, operated by a dedicated control.

Garmin ADAHRS (GSU25) unit, installed on the rear side of the fuselage near the battery, acts as an air data computer for Garmin G3X suite, it is connected to both static and total pressure lines providing on that suite both air speed and altitude information.

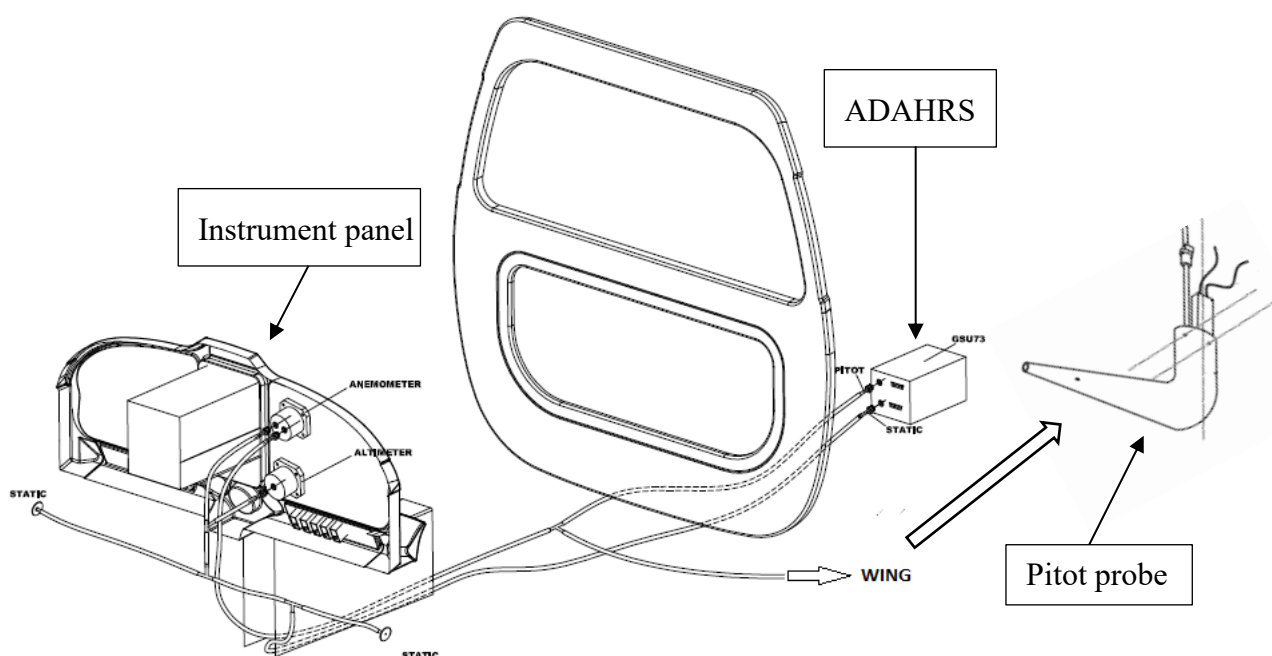

FIG.7-8. PITOT-STATIC SYSTEM

Supplement no. S9

MTV-34 Propeller for aircraft with MTOW Increment at 650 kg

Record of Revisions

Rev	Revised page	Description of Revision	Tecnam Approval			EASA Approval or Under DOA Privileges
			DO	OoA	HDO	
0	-	First Issue.	A. Sabino	M. Oliva	M. Oliva	EASA Approval Nr. 10063313
1	MT4-4	Paragraph shifted from page MT4-3; information added to normal operations speeds table.	A. Sabino	C. Caruso	M. Oliva	DOA Approval Nr. MOD2008/103.180312
	MT5-12 thru 13	Cruise performance revised.				
	MT6-9	CG Calculation example revised.				
	MTN3-18, MTN3-23, MT4-15, MTAN4-15, MT4-16, MT6-10 thru 11	Pages removed, information included in basic AFM.				
2	S9-1	LOEP correction	A. Sabino	D. Ronca	M. Oliva	DOA Approval Nr. MOD2008/123.190620
3	S9-1,2 MT7-10	LOEP correction Typo error	L. De Salvi	D. Ronca	M. Oliva	Approved under the authority of DOA, ref. EASA.21J.335 (MOD2008/188.230126)
4	S9-1 thru 6	Typo error	F. Paloni	D. Ronca	M. Oliva	Approved under the authority of DOA, ref. EASA.21J.335 (MOD2008/205.231020)

List of Effective Pages

	Page	Revision
Cover pages	S9-7 thru 16	Rev 1
	S9-1 thru 6	Rev 3
Section 1	MT1-6 thru 7	Rev 0
Section 2	MT2-5, 6, 9, 12, 16, 17, 21, MTN2-21	Rev 0
Section 3	MT3-9, MT3-17, , MT3-21	Rev 0
Section 4	MT4-4	Rev 3
Section 5	MT5-1 thru 11, MT5-14 thru 16	Rev 0
	MT5-12, 13	Rev 1
Section 6	MT6-5 thru 6	Rev 0
	MT6-9	Rev 1
Section 7	MT7-10	Rev 3

INDEX

INTRODUCTION 3
Section 1 – GENERAL 5
Section 2 – LIMITATIONS 7
Section 3 – EMERGENCY PROCEDURES..... 9
Section 4 – NORMAL PROCEDURES..... 11
Section 5 – PERFORMANCE 14
Section 6 – WEIGHT AND BALANCE 17
Section 7 – AIRFRAME AND SYSTEMS DESCRIPTION 20
Section 8 – GROUND HANDLING & SERVICE 9

Section 9 Supplements

Ed. 2, Rev. 3

Supplement no. S9

MTV-34 Propeller for airplanes with MTOW Increment at 650 kg

INTRODUCTION

This section contains supplemental information to operate the aircraft in a safe and efficient manner when equipped with MTV-34 propeller.

It is the owner's responsibility to replace the mentioned pages in accordance with the instructions herein addressed section by section.

INTENTIONALLY LEFT BLANK

Supplement S9: pages replacement instructions

SECTION 1 – GENERAL

**Make sure you first applied instructions reported on the basic AFM,
Section 1 General**

According A/C configuration apply following pages replacement:

Supplement S9 GENERAL pages		AFM Section 1 pages
MT1-6 and 7	REPLACES	1-6 and 7 of basic AFM, Section 1

INTENTIONALLY LEFT BLANK

5 ENGINE

Manufacturer	Bombardier-Rotax GmbH
Model	912 S2
Engine type	4 cylinders horizontally opposed with 1352 c.c. of overall displacement, liquid cooled cylinder heads, ram-air cooled cylinders, two carburetors, integrated reduction gear box with torsional shock absorber and overload clutch.
Maximum power (at declared rpm)	73.5 kW (98.6 hp) @ 5800 rpm <i>5 minutes maximum.</i> 69.0 kW (92.5 hp) @ 5500 rpm <i>maximum continuous.</i>

6 PROPELLER

Manufacturer	MT Propeller
Model	MTV-34-1-A/170-202
Number of blades	3
Construction	Laminated hard wood with epoxy fibre glass cover
Diameter	1700 mm
Type	Fixed pitch

7. FLIGHT CONTROL SURFACES TRAVEL

Ailerons	Up 22° Down 14 ° (± 2°)
Stabilator (refer to Trailing Edge)	Up 4° Down 15° (± 2°)
Stabilator trim tab (refer to Trailing Edge)	Up 2°; Down 12° (± 1°)
Rudder	RH 25° LH 25° (± 2°)
Flaps	0°; 35° (± 1°)

8. SPECIFIC LOADINGS

	MTOW 650 kg (1433lb)
Wing Loading	53.5 kg/m ² (10.9 lb/sqft)
Power Loading	6.59 kg/hp (14.53 lb/hp)

Supplement S9: pages replacement instructions

SECTION 2 – LIMITATIONS

**Make sure you first applied instructions reported on the basic AFM,
Section 2 Limitations**

According A/C configuration apply following pages replacement:

Supplement S9 pages		Basic AFM pages	Supplement S1 pages	Supplement S8 pages
MT2-5	REPLACES	2-5	/	/
MT2-6	REPLACES	2-6	/	M2-6
MT2-9	REPLACES	2-9	/	/
MT2-12	REPLACES	2-12	/	/
MT2-16	REPLACES	2-16	/	/
MT2-17	REPLACES	2-17	/	/
MT2-21	REPLACES	2-21	/	/
MTN2-21	REPLACES	/	2N-21	M-21

INTENTIONALLY LEFT BLANK

2. AIRSPEED LIMITATIONS

The following table addresses the airspeed limitations and their operational significance:

AIRSPEED		KIAS	KCAS	REMARKS
V _{NE}	Never exceed speed	143	139	Do not exceed this speed in any operation.
V _{NO}	Maximum Structural Cruising speed	111	110	Do not exceed this speed except in smooth air, and only with caution.
V _A	Design Manoeuvring speed	98	97	Do not make full or abrupt control movement above this speed, because under certain conditions the aircraft may be overstressed by full control movement.
V _O	Operating Manoeuvring speed			
V _{FE}	Maximum flaps extended speed	70	71	Do not exceed this speed for indicated flaps setting.

3. AIRSPEED INDICATOR MARKINGS

Airspeed indicator markings and their colour code are explained in the following table.

MARKING	KIAS	EXPLANATION
White arc/band	40 – 70	Positive Flap Operating Range (lower limit is V_{SO} , at specified maximum weight and upper limit is the maximum speed permissible with landing flaps extension).
Green arc/band	49 – 111	Normal Operating Range (lower limit is V_{S1} at specified maximum weight and most forward c.g. with flaps retracted and upper limit is maximum structural speed V_{NO}).
Yellow arc/band	111 – 143	Manoeuvres must be conducted with caution and only in smooth air.
Red line	143	Maximum speed for all operations.

9. PROPELLER

Manufacturer	MT Propeller
Model	MTV-34-1-A/170-202
Number of blades	3
Construction	Laminated hard wood with epoxy fibre glass cover
Diameter	1700 mm
Type	Fixed pitch

10. MAXIMUM OPERATING ALTITUDE

Maximum operating altitude is 13000ft (3962 m) MSL.



CAUTION

Flight crew is required to use supplemental oxygen according to applicable Air Operation Rules.

11. AMBIENT TEMPERATURE

Ambient temperature: from -25°C to +50°C.



WARNING

Flight in expected and/or known icing conditions is forbidden.

14. WEIGHTS

Condition	Weight	
Maximum takeoff weight	650 kg	1433lb
Maximum landing weight	650 kg	1433lb

Baggage Compartment		
Maximum weight	20 kg	44lb
Maximum specific pressure	12,5 kg/dm ²	256 lbs/sq in

16. APPROVED MANOEUVRES

The aircraft is certified in Normal Category in accordance with EASA CS-VLA regulation applying to aeroplanes intended for non-aerobatic operation only.

Non aerobatic operation includes:

- Any manoeuvre pertaining to “normal” flight
- Stalls (except whip stalls)
- Lazy eights
- Chandelles
- Steep turns in which the angle of bank is not more than 60°

Recommended entry speeds for each approved manoeuvre are as follows:

Manoeuvre	Speed [KIAS]
Lazy eight	98
Chandelle	111
Steep turn (max 60°)	98
Stall	Slow deceleration (1 kts/s)



Acrobatic manoeuvres, including spins and turns with angle of bank of more than 60°, are not approved for such a category.



Limit load factor could be exceeded by moving abruptly flight controls at their end run at a speed above V_A (Manoeuvring Speed: 98 KIAS).



Flight in expected and/or known icing conditions, in proximity of storms or in severe turbulence is forbidden.

17. MANOEUVRES LOAD FACTOR LIMITS

Manoeuvre load factors limits are as follows:

Positive	Negative
+ 3.8 g	- 1.9 g

Manoeuvre load factors limits with flaps extended are as follows:

Positive	Negative
+ 1.9 g	0 g

21. LIMITATIONS PLACARDS

The following limitation placards are placed in plain view on the pilot, reminding the observance of aircraft operating limitations according to installed equipment configuration (see KOEL, Para. 20).

Manoeuvring Speed
 $V_A = 98$ kts

This a/c is classified as VLA
approved for
DAY VFR
(with required equipment)
in non-icing conditions.
all aerobatics manoeuvres
including spinning are prohibited.
For operating limitations
refer to KOEL in the
FLIGHT MANUAL

On the right hand side of the instrument panel the following placard is placed reminding the observance for “no smoking”:

NO SMOKING

In the baggage compartment following placard is placed:

TIE-DOWN HARNESS
MAX WEIGHT 20kg [44 lbs]

DO NOT PLACE SHARP
OBJECTS ON THE FLOOR

21. LIMITATIONS PLACARDS

The following limitation placards are placed in plain view on the pilot, reminding the observance of aircraft operating limitations according to installed equipment configuration (see KOEL, Para. 20).

Manoeuvring Speed
 $V_A = 98$ kts

This a/c is classified as VLA
approved for
DAY OR NIGHT VFR
(with required equipment)
in non-icing conditions.
all aerobatics manoeuvres
including spinning are prohibited.
For operating limitations
refer to KOEL in the
FLIGHT MANUAL

On the right hand side of the instrument panel the following placard is placed reminding the observance for “no smoking”:

NO SMOKING

In the baggage compartment following placard is placed:

TIE-DOWN HARNESS
MAX WEIGHT 20kg [44 lbs]

DO NOT PLACE SHARP
OBJECTS ON THE FLOOR

Supplement S9: pages replacement instructions

SECTION 3 – EMERGENCY PROCEDURES

**Make sure you first applied instructions reported on the basic AFM,
Section 3 Emergency Procedures**

According A/C configuration apply following pages replacement:

Supplement S9 pages		Basic AFM pages
MT3-9	REPLACES	3-9
MT3-17	REPLACES	3-17
MT3-21	REPLACES	3-21

INTENTIONALLY LEFT BLANK

5. ENGINE FAILURE

5.1. ENGINE FAILURE DURING TAKE-OFF RUN

- | | |
|--------------|------------------------------|
| 1. Throttle: | <i>IDLE (keep fully out)</i> |
| 2. Rudder: | <i>Keep heading control</i> |
| 3. Brakes: | <i>apply as needed</i> |

when safely stopped:

- | | |
|---------------------------------|-------------|
| 4. Ignition key: | <i>OFF.</i> |
| 5. Fuel selector valve: | <i>OFF</i> |
| 6. Electric fuel pump: | <i>OFF</i> |
| 7. Alternator& Master switches: | <i>OFF.</i> |

5.2. ENGINE FAILURE IMMEDIATELY AFTER TAKE-OFF

- | | |
|--|-----------------------------|
| 1. Speed: | <i>keep minimum 61 KIAS</i> |
| 2. Find a suitable place to land safely. | |



The immediate landing should be planned straight ahead with only small changes in directions not exceeding 45° to the left or 45° to the right.

- | | |
|-----------|------------------|
| 3. Flaps: | <i>as needed</i> |
|-----------|------------------|



Stall speed increases with bank angle and longitudinal load factor. Acoustic stall warning will in any case provides a correct anticipated cue of incipient stall.

At, or right before, touch down

- | | |
|---------------------------------|----------------------------------|
| 4. Throttle: | <i>IDLE (fully out and hold)</i> |
| 5. Ignition key: | <i>OFF</i> |
| 6. Fuel selector valve: | <i>OFF</i> |
| 7. Electric fuel pump: | <i>OFF</i> |
| 8. Alternator& Master switches: | <i>OFF</i> |



A single engine aircraft take off should always be preceded by a thorough take off emergency pilot self-briefing. Decision to try an engine emergency restart right after take off should be taken only if environmental situation requires it: pilot shall never ignore the priority of attentively follow an immediate emergency landing.

After possible mechanical engine seizure, fire or a major propeller damage, engine restart attempt is not recommended.

8. LANDING EMERGENCIES

8.1 FORCED LANDING WITHOUT ENGINE POWER

1. Flaps: UP
2. Airspeed: 72 KIAS
3. Find a suitable place to land safely, plan to approach it upwind.
4. Fuel selector valve: OFF
5. Electric fuel pump: OFF
6. Ignition key: OFF
7. Safety belts: Tighten

When certain to land

8. Flaps: *as necessary*
9. Alternator and Master switches: OFF.

NOTE

Glide ratio is 12.8, therefore in zero wind conditions for every 1000ft above Ground Level it is possible to cover ca. 2 NM.

8.2 POWER-ON FORCED LANDING

1. Airspeed: 72KIAS
2. Flaps: UP
3. Locate the most suitable terrain for emergency landing, plan to approach it upwind.
4. Safety belts: Tighten

When certain to land, right before touch down

5. Flaps: *as necessary*
6. Fuel selector valve: OFF
7. Electric fuel pump: OFF
8. Ignition key: OFF
9. Alternator and Master switches: OFF

8.3 LANDING WITH A FLAT NOSE TIRE

1. Pre-landing checklist: Complete
2. Flaps: Land
3. Land and maintain aircraft NOSE HIGH attitude as long as possible.

As aircraft stops

4. Engine securing: Perform(see Para. 4)
5. Airplane evacuation: Perform(see Para. 3)

10.2 TRIM SYSTEM FAILURE

Trim Jamming

Should trim control be inoperative, act as follows:

1. Breaker: *CHECK IN*
2. LH/RH Trim switch: *CHECK for correct position*

If jamming persists

1. Trim cutout switch: *CHECK ON*
2. Speed: *adjust to control aircraft without excessive stick force*
3. **Land aircraft as soon as possible.**

Trim Runaway

In event of trim runaway, act as follows:

1. Trim cutout switch: *OFF*
2. Speed: *adjust to control aircraft without excessive stick force*
3. **Land aircraft as soon as possible.**

10.3 FLAPS FAILURE

In event of flaps-up landing, account for:

- Approach speed: *65 KIAS*
Landing length: *35% increased*

Supplement S9: pages replacement instructions

SECTION 4 – NORMAL PROCEDURES

**Make sure you first applied instructions reported on the basic AFM,
Section 4 Normal Procedures**

According A/C configuration apply following pages replacement:

Supplement S9 pages		Basic AFM pages
MT4-4	REPLACES	4-4

2. AIRSPEEDS FOR NORMAL OPERATIONS

The following airspeeds are those which are significant for normal operations.

	FLAPS	650kg
Rotation Speed (V_R)	T/O	50 KIAS
Flap Retraction Speed (V_{OBS})	T/O	61 KIAS
Best Angle-of-Climb Speed (V_X)	0°	64 KIAS
Best Rate-of-Climb speed (V_Y)	0°	68 KIAS
Approach speed	T/O	61 KIAS
Final Approach Speed	FULL	55 KIAS
Touch Down Speed	FULL	55 KIAS
Manoeuvring speed (V_A)	0°	98 KIAS
Never Exceed Speed (V_{NE})	0°	143 KIAS

Supplement S9: pages replacement instructions

SECTION 5 – PERFORMANCE

**Make sure you first applied instructions reported on the basic AFM,
Section 5 Performance**

According A/C configuration apply following pages replacement:

Supplement S9 – Performance pages replace basic AFM Section 5 as a whole.

SECTION 5 – PERFORMANCE

1. INTRODUCTION	2
2. USE OF PERFORMANCE CHARTS	2
3. AIRSPEED INDICATOR SYSTEM CALIBRATION	3
4. ICAO STANDARD ATMOSPHERE	4
5. STALL SPEED	5
6. CROSSWIND	6
7. TAKE-OFF PERFORMANCE	7
8. TAKE-OFF RATE OF CLIMB	10
9. EN-ROUTE RATE OF CLIMB	11
10. CRUISE PERFORMANCE	12
11. LANDING PERFORMANCE	14
12. BALKED LANDING PERFORMANCE	15
13. NOISE DATA	15

1. INTRODUCTION

This section provides all necessary data for an accurate and comprehensive planning of flight activity from take-off to landing.

Data reported in graphs and/or in tables were determined using:

- ✓ “Flight Test Data” under conditions prescribed by EASA CS-VLA regulation
- ✓ aircraft and engine in good condition
- ✓ average piloting techniques

Each graph or table was determined according to ICAO Standard Atmosphere (ISA - s.l.); evaluations of the impact on performance were carried out by theoretical means for:

- ✓ Airspeed
- ✓ External temperature
- ✓ Altitude
- ✓ Weight
- ✓ Runway type and condition

2. USE OF PERFORMANCE CHARTS

Performance data are presented in tabular or graphical form to illustrate the effect of different variables such as altitude, temperature and weight. Given information is sufficient to plan the mission with required precision and safety.

Additional information is provided for each table or graph.

3. AIRSPEED INDICATOR SYSTEM CALIBRATION

Graph shows calibrated airspeed V_{IAS} as a function of indicated airspeed V_{CAS} .

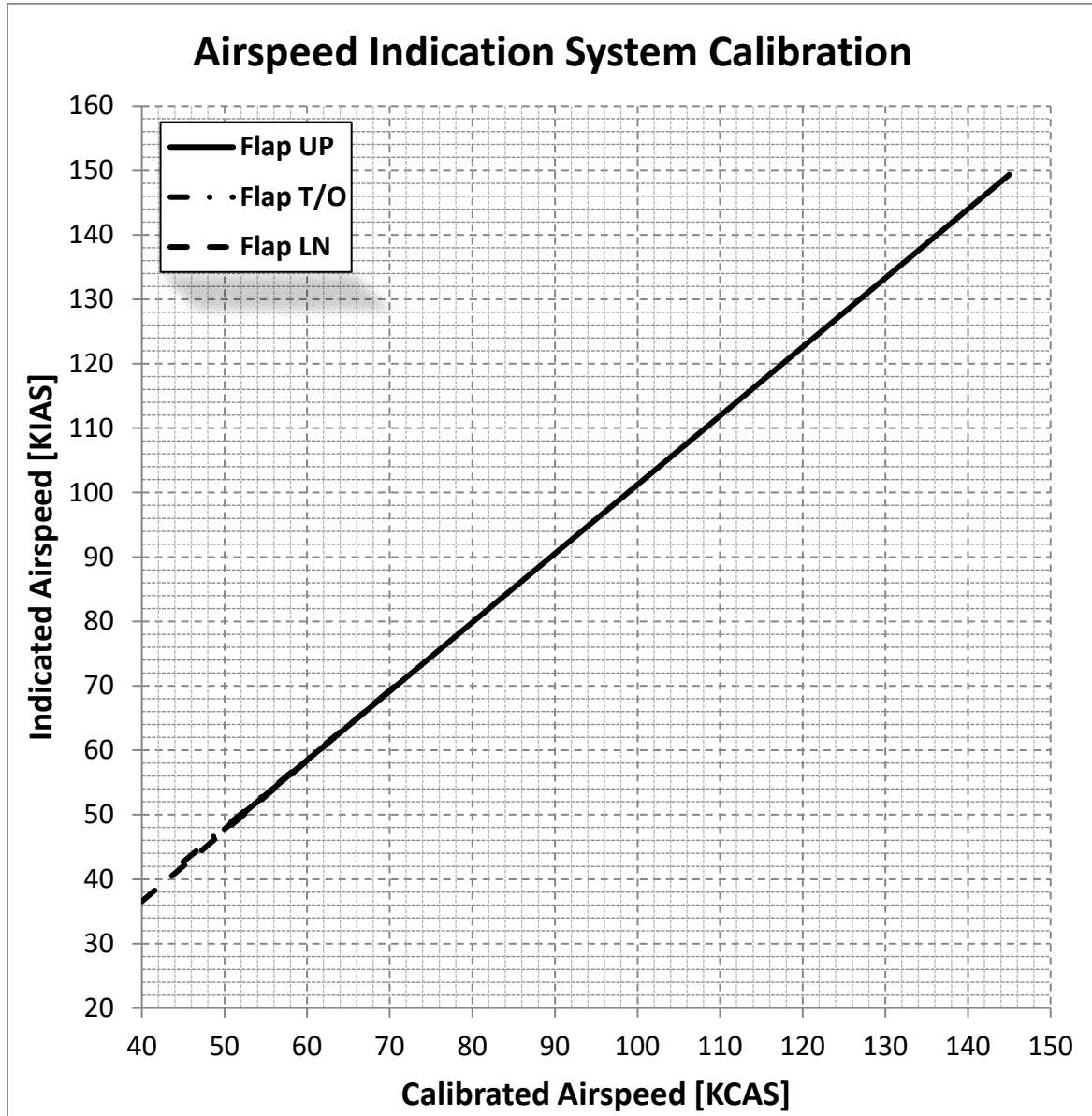

FIG. 5-1. CALIBRATED VS INDICATED AIRSPEED

Example:

Given

KIAS 75.0

Flap: UP

Found

KCAS 74.5

NOTE

Indicated airspeed assumes 0 as an instrument error

4. ICAO STANDARD ATMOSPHERE

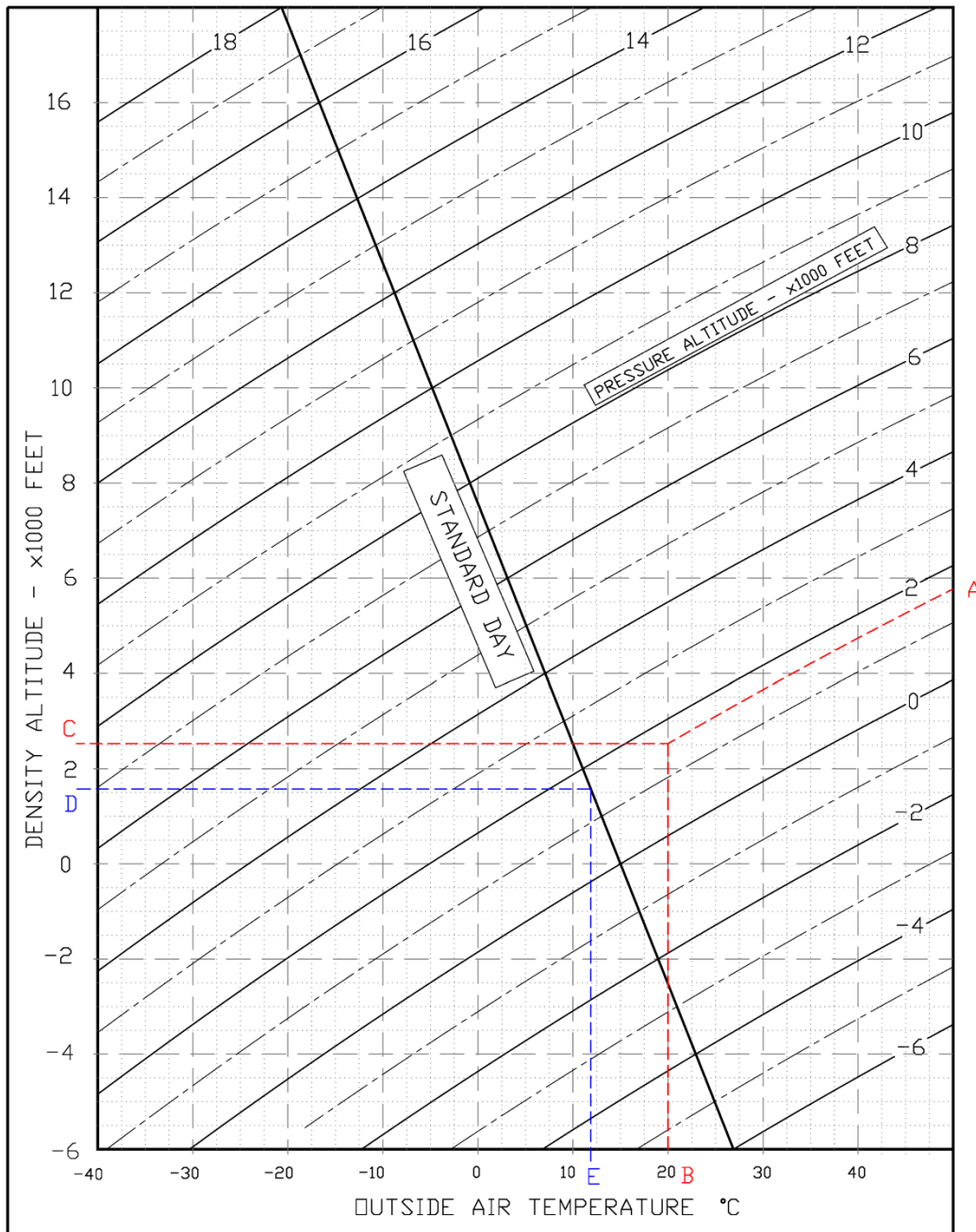

FIG. 5-2. ICAO CHART

Examples:

<u>Scope</u>	<u>Given</u>	<u>Find</u>
DensityAltitude:	A: Pressure altitude = 1600ft B: Temperature = 20°C	→ C: DensityAltitude = 2550ft
ISA Temperature:	D: Pressure altitude = 1600ft	→ E: ISA Air Temperature = 12°C

5. STALL SPEED

Weight: 650 kg Throttle Levers: IDLE CG: Most Forward (20%) No ground effect							
WEIGHT [kg]	BANK ANGLE [deg]	STALL SPEED					
		FLAPS 0°		FLAPS T/O		FLAPS FULL	
		KIAS	KCAS	KIAS	KCAS	KIAS	KCAS
650 (FWD C.G.)	0	49	51	46	48	40	44
	15	50	52	46	49	41	44
	30	53	55	49	51	44	47
	45	59	61	55	57	49	52
	60	71	72	67	67	60	62

NOTE

Altitude loss during conventional stall recovery, as demonstrated during flight tests is approximately 350 ft with banking below 30°.

6. CROSSWIND

Maximum demonstrated crosswind is 15Kts

⇒Example:

Given

Wind direction (with respect to aircraft longitudinal axis)= 30°

Wind speed = 20 Kts

Found

Headwind = 17.5 Kts

Crosswind = 10 Kts

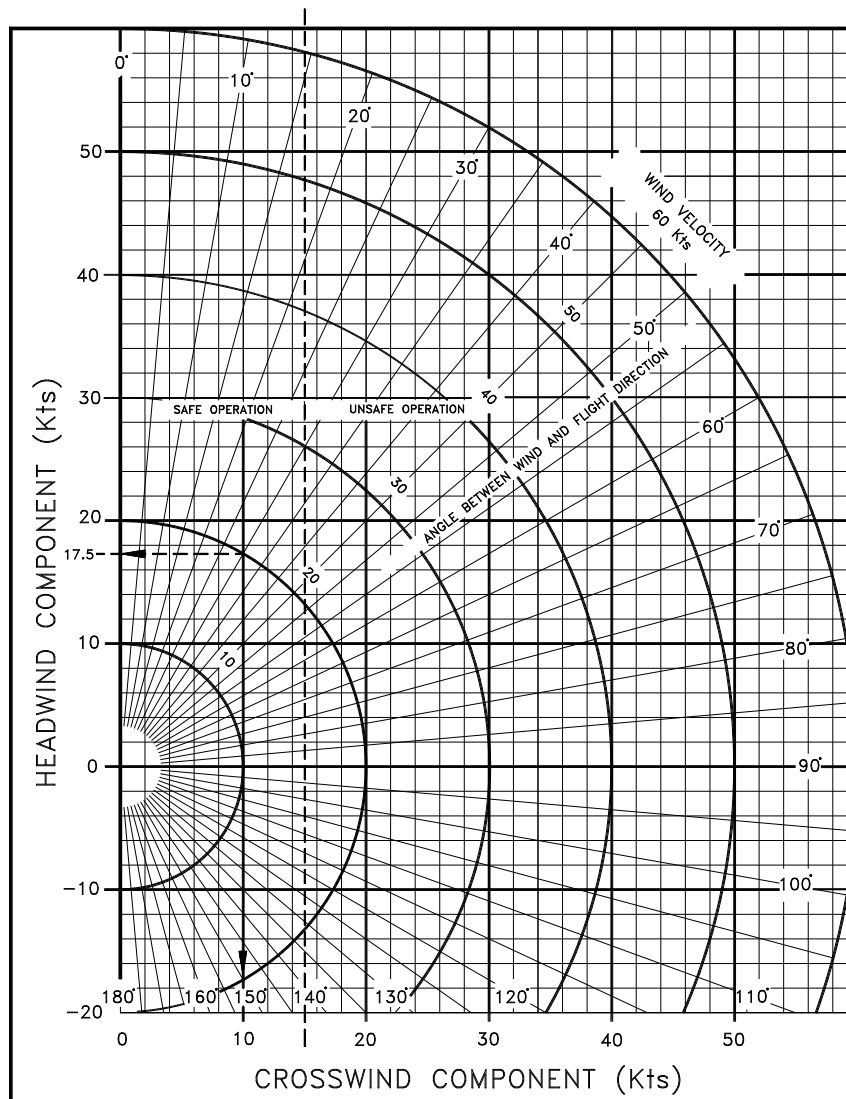

FIG. 5-2. CROSSWIND CHART

7. TAKE-OFF PERFORMANCE

NOTE

To account for likely in service performance variations apply a factored to distances of 1.10

Weight = 650 kg Flaps: T/O Speed at Lift-Off = 50 KIAS Speed Over 50ft Obstacle = 61 KIAS Throttle Levers: Full Forward Runway: Grass		Corrections Headwind: - 5 m for each kt (16 ft/kt) Tailwind: + 15 m for each kt (49 ft/kt) Paved Runway: - 10% to Ground Roll Runway slope: + 7% to Ground Roll for each +1%				
Pressure Altitude		Distance [m]				ISA
		Temperature [°C]				
[ft]		-25	0	25	50	
S.L.	Ground Roll	149	187	231	280	213
	At 50 ft AGL	262	328	401	484	371
1000	Ground Roll	162	204	252	306	228
	At 50 ft AGL	285	356	437	526	397
2000	Ground Roll	177	223	275	334	245
	At 50 ft AGL	311	388	475	572	425
3000	Ground Roll	193	244	301	365	263
	At 50 ft AGL	338	422	517	623	455
4000	Ground Roll	211	266	328	398	283
	At 50 ft AGL	368	460	564	679	488
5000	Ground Roll	231	291	359	436	304
	At 50 ft AGL	402	502	614	740	524
6000	Ground Roll	253	319	393	477	327
	At 50 ft AGL	438	547	670	808	562
7000	Ground Roll	277	349	430	522	352
	At 50 ft AGL	478	597	732	882	603
8000	Ground Roll	304	382	472	572	379
	At 50 ft AGL	522	652	799	963	648
9000	Ground Roll	333	419	517	627	409
	At 50 ft AGL	571	713	874	1053	696
10000	Ground Roll	365	460	567	688	441
	At 50 ft AGL	624	780	956	1152	748

Weight = 600 kg Flaps: T/O Speed at Lift-Off = 50 KIAS Speed Over 50ft Obstacle = 61 KIAS Throttle Levers: Full Forward Runway: Grass		Corrections Headwind: - 5 m for each kt (16 ft/kt) Tailwind: + 15 m for each kt (49 ft/kt) Paved Runway: - 10% to Ground Roll Runway slope: + 7% to Ground Roll for each +1%				
Pressure Altitude		Distance [m]				ISA
		Temperature [°C]				
[ft]		-25	0	25	50	
S.L.	Ground Roll	123	155	191	231	176
	At 50 ft AGL	218	272	333	402	308
1000	Ground Roll	134	169	208	252	188
	At 50 ft AGL	237	296	363	437	330
2000	Ground Roll	146	184	227	275	202
	At 50 ft AGL	258	322	395	476	353
3000	Ground Roll	160	201	248	301	217
	At 50 ft AGL	281	351	430	518	378
4000	Ground Roll	174	220	271	329	234
	At 50 ft AGL	306	382	468	564	406
5000	Ground Roll	191	240	296	360	251
	At 50 ft AGL	334	417	510	615	435
6000	Ground Roll	209	263	324	394	270
	At 50 ft AGL	364	455	557	671	467
7000	Ground Roll	229	288	355	431	291
	At 50 ft AGL	397	496	608	732	501
8000	Ground Roll	251	315	389	472	313
	At 50 ft AGL	434	542	664	800	538
9000	Ground Roll	275	346	427	518	337
	At 50 ft AGL	474	592	726	875	578
10000	Ground Roll	301	379	468	568	364
	At 50 ft AGL	519	648	794	957	622

Weight = 550 kg Flaps: T/O Speed at Lift-Off = 50 KIAS Speed Over 50ft Obstacle = 61 KIAS Throttle Levers: Full Forward Runway: Grass		Corrections Headwind: - 5 m for each kt (16 ft/kt) Tailwind: + 15 m for each kt (49 ft/kt) Paved Runway: - 10% to Ground Roll Runway slope: + 7% to Ground Roll for each +1%				
Pressure Altitude		Distance [m]				ISA
		Temperature [°C]				
[ft]		-25	0	25	50	
S.L.	Ground Roll	100	125	155	188	143
	At 50 ft AGL	178	223	273	329	252
1000	Ground Roll	109	137	169	205	153
	At 50 ft AGL	194	242	297	357	270
2000	Ground Roll	119	149	184	224	164
	At 50 ft AGL	211	263	323	389	289
3000	Ground Roll	130	163	201	244	176
	At 50 ft AGL	230	287	351	423	309
4000	Ground Roll	142	178	220	267	190
	At 50 ft AGL	250	313	383	461	332
5000	Ground Roll	155	195	241	292	204
	At 50 ft AGL	273	341	417	503	356
6000	Ground Roll	169	213	263	319	219
	At 50 ft AGL	298	372	455	549	382
7000	Ground Roll	186	234	288	350	236
	At 50 ft AGL	325	406	497	599	410
8000	Ground Roll	203	256	316	383	254
	At 50 ft AGL	355	443	543	654	440
9000	Ground Roll	223	281	346	420	274
	At 50 ft AGL	388	484	593	715	473
10000	Ground Roll	245	308	380	461	295
	At 50 ft AGL	424	530	649	782	508

8. TAKE-OFF RATE OF CLIMB

NOTE

To account for likely in service performance variations apply a factored to rate of climb of 0.90

Throttle Levers: Full Forward							
Flaps: Take Off (15°)							
Weight	Pressure Altitude	Climb Speed V _Y	Rate of Climb [ft/min]				ISA
			Temperature [°C]				
[kg]	[ft]	[KIAS]	-25	0	25	50	
650	S.L.	65	897	756	629	516	678
	2000	64	790	651	527	415	594
	4000	64	682	546	424	314	510
	6000	64	576	442	322	214	426
	8000	64	469	338	220	114	342
	10000	64	363	234	118	14	258
	12000	64	258	131	17	-85	174
	14000	64	152	28	-84	-184	90
600	S.L.	64	1014	864	731	610	782
	2000	64	900	753	622	504	693
	4000	64	787	642	513	397	605
	6000	63	674	532	405	291	516
	8000	63	561	422	297	185	427
	10000	63	449	312	190	80	338
	12000	63	337	203	83	-25	249
	14000	63	226	94	-24	-130	160
550	S.L.	64	1148	989	846	718	901
	2000	63	1027	870	730	604	807
	4000	63	906	752	615	491	712
	6000	62	786	635	500	378	617
	8000	62	666	517	385	265	522
	10000	61	547	401	270	153	428
	12000	61	427	284	156	41	333
	14000	60	309	168	43	-70	238

9. EN-ROUTE RATE OF CLIMB

NOTE

To account for likely in service performance variations apply a factored to rate of climb of 0.90

Throttle Levers: Full Forward		Flaps: UP					
Weight	Pressure Altitude	Climb Speed V_Y	Rate of Climb [ft/min]				ISA
			Temperature [°C]				
[kg]	[ft]	[KIAS]	-25	0	25	50	
650	S.L.	67	998	840	702	576	754
	2000	67	882	729	592	468	667
	4000	67	764	613	479	357	574
	6000	67	646	498	366	246	481
	8000	68	529	383	253	136	388
	10000	68	412	269	141	26	295
	12000	68	295	155	29	-84	202
	14000	68	179	41	-82	-193	109
600	S.L.	66	1128	962	813	679	871
	2000	66	1002	838	692	560	772
	4000	67	876	715	571	442	673
	6000	67	750	592	451	323	574
	8000	67	625	469	331	206	474
	10000	67	500	347	211	88	375
	12000	67	375	225	92	-29	276
	14000	68	251	104	-27	-145	177
550	S.L.	65	1275	1096	936	792	998
	2000	66	1139	963	806	664	892
	4000	66	1003	830	676	536	785
	6000	66	868	698	546	409	678
	8000	67	733	566	417	282	572
	10000	67	599	435	288	156	465
	12000	67	465	304	160	30	358
	14000	67	331	173	32	-95	252

10. CRUISE PERFORMANCE



Propeller speed over 2265 RPM is restricted to 5min.

Weight = 650 kg							
CORRECTIONS							
	KTAS	Fuel Consumption	Endurance	Range	Specific Range		
For each +15°C of OAT	-2%	-2.5%	+2%	+1%	+1%		
For each -15°C of OAT	+1%	+3%	-4%	-2%	-1%		
For -100kg of weight	+3.3%	-	-	+3%	+4%		
CRUISE PERFORMANCE							
Pressure Altitude [ft]	OAT ISA [deg C]	Propeller RPM	KTAS	Fuel Consumption [lt/hr]	Endurance [hr:mm]	Range [nm]	Specific Range [nm/lt]
0	15	2388	116	27.7	4:20	503	4.2
		2250	109	25.8	4:39	507	4.2
		2100	100	22.1	5:26	543	4.5
		2000	94	19.5	6:09	579	4.8
		1900	88	17.6	6:49	600	5.0
		1800	81	15.9	7:33	611	5.1
2000	11	2250	108	25	4:48	518	4.3
		2100	99	20.9	5:44	568	4.7
		2000	93	18.8	6:23	594	5.0
		1900	87	17	7:04	614	5.1
		1800	81	15.5	7:45	627	5.2

Weight = 650 kg							
CORRECTIONS							
	KTAS	Fuel Consumption	Endurance	Range	Specific Range		
For each +15°C of OAT	-2%	-2.5%	+2%	+1%	+1%		
For each -15°C of OAT	+1%	+3%	-4%	-2%	-1%		
For -100kg of weight	+3.3%	-	-	+3%	+4%		
CRUISE PERFORMANCE							
Pressure Altitude [ft]	OAT ISA [deg C]	Propeller RPM	KTAS	Fuel Consumption [lt/hr]	Endurance [hr:mm]	Range [nm]	Specific Range [nm/lt]
4000	7	2250	106	23.9	5:01	532	4.4
		2100	98	20	6:00	588	4.9
		2000	92	18.1	6:38	610	5.1
		1900	86	16.5	7:16	626	5.2
		1800	79	15.2	7:54	624	5.2
6000	3	2250	105	22.7	5:17	555	4.6
		2100	97	19.2	6:15	606	5.1
		2000	91	17.5	6:51	624	5.2
		1900	85	16.1	7:27	634	5.3
		1800	78	14.9	8:03	628	5.2
8000	-1	2250	104	21.5	5:35	581	4.8
		2100	96	18.5	6:29	623	5.2
		2000	90	17	7:04	635	5.3
		1900	84	15.7	7:39	642	5.4
10000	-5	2250	103	20.5	5:51	603	5.0
		2100	95	17.9	6:42	637	5.3
		2000	89	16.6	7:14	643	5.4
		1900	82	15.5	7:45	635	5.3

11. LANDING PERFORMANCE

NOTE

To account for likely in service performance variations apply a factored to distances of 1.67

Weight = 650 kg		Corrections				
Flaps: LAND		Headwind: -4m for each kt (13 ft/kt)				
Short Final Approach Speed = 54 KIAS		Tailwind: + 13m for each kt (43 ft/kt)				
Throttle Levers: Idle		Paved Runway:-10% to Ground Roll				
Runway: Grass		Runway slope: -3% to Ground Roll for each +1%				
Pressure Altitude [ft]		Distance [m]				
		Temperature [°C]				ISA
		-25	0	25	50	
S.L.	Ground Roll	149	164	179	194	173
	At 50 ft AGL	358	373	388	403	382
1000	Ground Roll	154	170	186	201	178
	At 50 ft AGL	363	379	395	410	387
2000	Ground Roll	160	176	192	209	183
	At 50 ft AGL	369	385	401	418	392
3000	Ground Roll	166	183	200	216	189
	At 50 ft AGL	375	392	409	425	398
4000	Ground Roll	172	190	207	225	195
	At 50 ft AGL	381	399	416	434	404
5000	Ground Roll	179	197	215	233	201
	At 50 ft AGL	388	406	424	442	410
6000	Ground Roll	186	205	223	242	207
	At 50 ft AGL	395	414	432	451	416
7000	Ground Roll	193	212	232	251	213
	At 50 ft AGL	402	421	441	460	422
8000	Ground Roll	200	221	241	261	220
	At 50 ft AGL	410	430	450	470	429
9000	Ground Roll	208	229	250	271	227
	At 50 ft AGL	417	438	459	480	436
10000	Ground Roll	217	238	260	282	234
	At 50 ft AGL	426	447	469	491	443

12. BALKED LANDING PERFORMANCE

NOTE

To account for likely in service performance variations apply a factored to rate of climb and to angle of climb of 0.90

Throttle Levers: Full Forward						
Flaps: LAND						
Speed: 54 KIAS						
Weight	Pressure Altitude	Angle of Climb [deg]				ISA
		Temperature [°C]				
[kg]	[ft]	-25	0	25	50	
650	S.L.	10.3	8.2	6.3	4.6	7.0
	2000	8.7	6.6	4.7	3.0	5.8
	4000	7.1	5.0	3.2	1.5	4.5
	6000	5.5	3.4	1.6	0.0	3.2
	8000	3.9	1.9	0.1	-1.5	1.9
	10000	2.3	0.3	-1.4	-3.0	0.7
	12000	0.7	-1.3	-3.0	-4.5	-0.6
	14000	-0.9	-2.8	-4.5	-6.0	-1.9

13. NOISE DATA

Noise level, determined in accordance with ICAO/Annex 16 6th Ed., July 2011, Vol. I°, Chapter 10, is **63.19** dB(A).

INTENTIONALLY LEFT BLANK

Supplement S9: pages replacement instructions

SECTION 6 – WEIGHT AND BALANCE

**Make sure you first applied instructions reported on the basic AFM,
Section 6 Weight and Balance**

According A/C configuration apply following pages replacement:

Supplement S9 pages		Basic AFM pages
MT6-5 thru 6	REPLACE	6-5 thru 6
MT6-9	REPLACES	6-9

2.5. WEIGHING RECORD

Model **P2008 JC** S/N: _____ Weighing no. _____ Date: _____

Datum: Propeller Flange

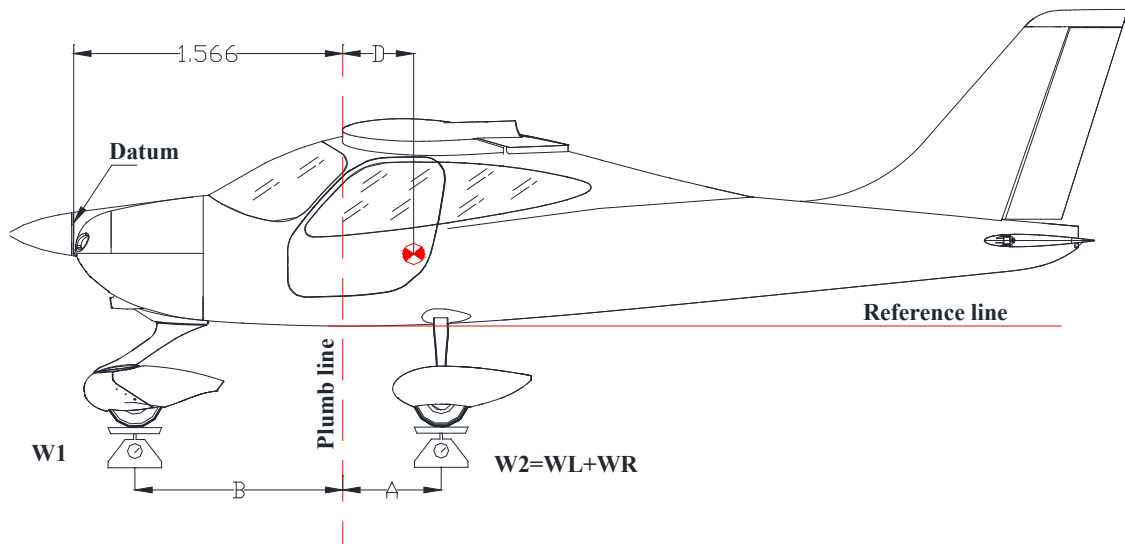

	<i>Kg or Lbs</i>		<i>Meters or feet</i>
Nose wheel weight	$W_1 =$	Plumb bob distance LH wheel	$A_L =$
LH wheel weight	$W_L =$	Plumb bob distance RH wheel	$A_R =$
RH wheel weight	$W_R =$	Average distance $(A_L + A_R)/2$	$A =$
$W_2 = W_L + W_R =$		Plumb bob distance from nose wheel	$B =$

Empty weight $W_e = W_1 + W_2 =$ [kg] or [lbs]

$D = \frac{W_2 \cdot A - W_1 \cdot B}{W_e}$ [m] or [Ft] $D\% = \frac{D}{1.373 \text{ m (or 4.5 ft)}} \cdot 100 =$

Empty weight moment: $M = [(D+1.566) \cdot W_e] =$ [m · kg] or [ft · lbs]

Maximum takeoff weight	$W_T = 650 \text{ kg}$	(1433 lbs)	Signature _____ _____
Empty weight	$W_e =$	[kg] or [lbs]	
Max. useful load $W_T - W_e$	$W_u =$	[kg] or [lbs]	

2.6. WEIGHING RECORD (II)

Model **P2008 JC** S/N: _____ Weighing no. _____ Date: _____

Datum: Propeller Flange

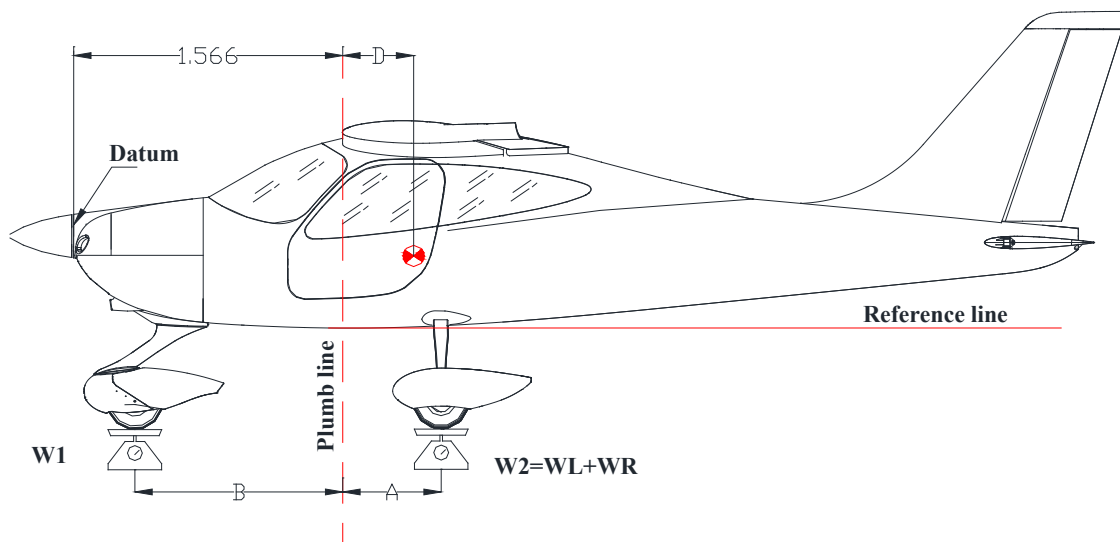

	<i>Kg or Lbs</i>		<i>Meters or feet</i>
Nose wheel weight	$W_1 =$	Plumb bob distance LH wheel	$A_L =$
LH wheel weight	$W_L =$	Plumb bob distance RH wheel	$A_R =$
RH wheel weight	$W_R =$	Average distance $(A_L + A_R)/2$	$A =$
$W_2 = W_L + W_R =$		Plumb bob distance from nose wheel	$B =$

Empty weight $W_e = W_1 + W_2 =$ [kg] or [lbs]

$D = \frac{W_2 \cdot A - W_1 \cdot B}{W_e} =$ [m] or [ft] $D\% = \frac{D}{1.373 \text{ m (or 4.5 ft)}} \cdot 100 =$

Empty weight moment: $M = [(D+1.566) \cdot W_e] =$ [m · kg] or [ft · lbs]

Maximum takeoff weight	$W_T = 650 \text{ kg}$	(1433 lbs)	Signature _____ _____
Empty weight	$W_e =$	[kg] or [lbs]	
Max. useful load $W_T - W_e$	$W_u =$	[kg] or [lbs]	

C.G.Range	Max FWD	Max AFT
Meters	1.841	1.978

Max Weight	Pounds	Kilograms
	1433.00	650.00

Example						
	Weight		Arm		Moment	
	<i>lbs</i>	<i>kg</i>	<i>in</i>	<i>m</i>	<i>lbs in</i>	<i>kg m</i>
Empty	813.5	369.0	74.4	1.89	60533	697.4
Fuel	150.0	68.0	87.0	2.21	13052	150.4
Pax	300.0	136.1	70.9	1.80	21270	245.1
Baggage	0	0	94.9	2.41	0	0
Total	1263.5	573.1	75.1	1.91	94854	1092.8

In this example, the gross weight is under the max gross weight and the Arm or C.G. is within the C.G. range listed above.

4. BAGGAGE LOADING

The baggage loading in the dedicated compartment, behind the pilots' seats, must be carried out in accordance with C.G. excursion and weight limitations reported in Section 2.

Baggage must be uniformly distributed on compartment floor.

Pilot is provided with a red tie-down net and snap fasteners allowing for securing the loads on the compartment floor.



Loading the baggage, make sure that you correctly stretched the net which must be secured to the four vertices of the compartment.

Supplement S9: pages replacement instructions

SECTION 7 – AIRFRAME AND SYSTEMS DESCRIPTION

Make sure you first applied instructions reported on the basic AFM,
Section 7 Airframe and Systems Description

Apply following pages replacement:

Supplement S9 pages		Basic AFM pages
MT7-10	REPLACES	7-10

7. POWERPLANT

7.1. ENGINE

Manufacturer: *Bombardier-Rotax GmbH*
Model: *ROTAX 912 S2*
Type: *4 stroke, horizontally-opposed 4 cylinder, mixed air and water cooled, twin electronic ignition, forced lubrication.*
Maximum rating: *98.6hp (73.5kW) @ 5800 rpm/min (2388 rpm/min. prop).
Gear reduction ratio - 2.4286:1*
Max oil consumption: *Max: 0.1 litres/hour*

7.2. PROPELLER

Manufacturer: *MT Propeller*
Model: *MTV-34-1-A/170-202*
N° of blades: *3*
Diameter: *1700 mm*
Type: *fixed pitch*

Supplement S9: pages replacement instructions

SECTION 8 – GROUND HANDLING & SERVICE

**Make sure you first applied instructions reported on the basic AFM,
Section 8 Ground Handling & Service**

Refer to the basic AFM, Section 8 – Ground Handling & Service.

INTENTIONALLY LEFT BLANK

**Supplement no. S10
GARMIN GTX 3X5**

Record of Revisions

Rev	Revised page	Description of Revision	Tecnam Approval			EASA Approval or Under DOA Privileges
			DO	OoA	HDO	
0	-	First issue	A. Sabino	C. Caruso	M. Oliva	Approved under the authority of DOA, ref. EASA.21J.335 (MOD2008/103.180312)
1	All	Extended applicability to GTX 345 model (MOD2008/140).	G.Valentino	D.Ronca	M. Oliva	Approved under the authority of DOA, ref. EASA.21J.335 (MOD2008/143.200730)
2	All	Typo corrections	F. Paloni	D. Ronca	M. Oliva	Approved under the authority of DOA, ref. EASA.21J.335 (MOD2008/216.240508)
3	S10-1, S10-3	MOD2008/239	F. Losappio	D. Ronca	M. Oliva	Approved under the authority of DOA, ref. EASA.21J.335 (MOD2008/239.250630)

List of Effective Pages

Page	Revision
S10-1	<i>Rev 3</i>
S10-2	<i>Rev 2</i>
S10-3	<i>Rev 3</i>
S10-4	<i>Rev 2</i>

INTRODUCTION

The information contained herein supplement or supersede the basic Aircraft Flight Manual. GTX 3X5 transponder comes optionally installed. This supplement furnishes essential information about this installation.

NOTE

For detailed operational instructions related to this equipment, see last issues of GARMIN publications.

SECTION 1 GENERAL

Refer to the basic AFM.

SECTION 2 LIMITATIONS

Refer to the basic AFM.

SECTION 3 EMERGENCY PROCEDURES

Refer to the basic AFM.

SECTION 4 NORMAL PROCEDURES

Refer to the basic AFM.

SECTION 5 PERFORMANCE

Refer to the basic AFM.

SECTION 6 WEIGHT AND BALANCE

Refer to the basic AFM.

SECTION 7 AIRFRAME AND SYSTEMS DESCRIPTION

NOTE

Make sure you first applied instructions reported on the basic AFM, Section 7 Airframe and Systems Description.

AVIONICS

GTX 3X5 is installed in the center of the cockpit under the GNC 255A or GNC 215.

The unit is shown in Fig.1. The transponder is associated with an antenna, placed under the a/c, and with a GPS antenna installed in order to have a source for the ADS-B OUT.



Fig. 1. GARMIN GTX 3X5 (only for reference)

SECTION 8 GROUND HANDLING & SERVICE

Refer to the basic AFM.

**Supplement no. S11
KR87 ADF System**

Record of Revisions

Rev	Revised page	Description of Revision	Tecnam Approval			EASA Approval or Under DOA Privileges
			DO	OoA	HDO	
0	-	First issue	A. Sabino	C. Caruso	M. Oliva	Approved under the authority of DOA, ref. EASA.21J.335 (MOD2008/103.180312)
1	S11-1, 4	MOD2008/230	F. Losappio	D. Ronca	M. Oliva	Approved under the authority of DOA, ref. EASA.21J.335 (MOD2008/230.250430)

List of Effective Pages

Page	Revision
S11-2, 3	<i>Rev 0</i>
S11-1, 4	<i>Rev 1</i>

INTRODUCTION

The information contained herein supplement or supersede the basic Aircraft Flight Manual. KR87 is an ADF system that comes optionally installed. This supplement furnishes essential information about this installation.

NOTE

For detailed operational instructions related to this equipment, see last issues of the manufacturer's publications.

SECTION 1 GENERAL

Refer to the basic AFM.

SECTION 2 LIMITATIONS

Refer to the basic AFM.

SECTION 3 EMERGENCY PROCEDURES

Refer to the basic AFM.

SECTION 4 NORMAL PROCEDURES

Refer to the basic AFM.

SECTION 5 PERFORMANCE

Refer to the basic AFM.

SECTION 6 WEIGHT AND BALANCE

Refer to the basic AFM.

SECTION 7 AIRFRAME AND SYSTEMS DESCRIPTION

NOTE

Make sure you first applied instructions reported on the basic AFM, Section 7 Airframe and Systems Description.

INSTRUMENT PANEL

The ADF Receiver is installed in the center of the instrument panel. The KI 227 (Fig. 2) is a single needle ADF Indicator and is the basic indicator used with the KR 87 (Fig. 1), it is installed at the left side of the PFD replacing the slip-skid indicator. In the new configuration, the slip-skid indicator is located under the lower side of the PFD.



Fig. 1. - KR87 ADF Receiver Panel



Fig. 2. - KI 227 Indicator Panel

ELECTRICAL SYSTEM

The Marker Beacon Antenna is placed on the lower side of the tail cone, next to the COM antenna. The ADF antenna is installed under the fuselage behind the battery compartment (see Fig. 3).

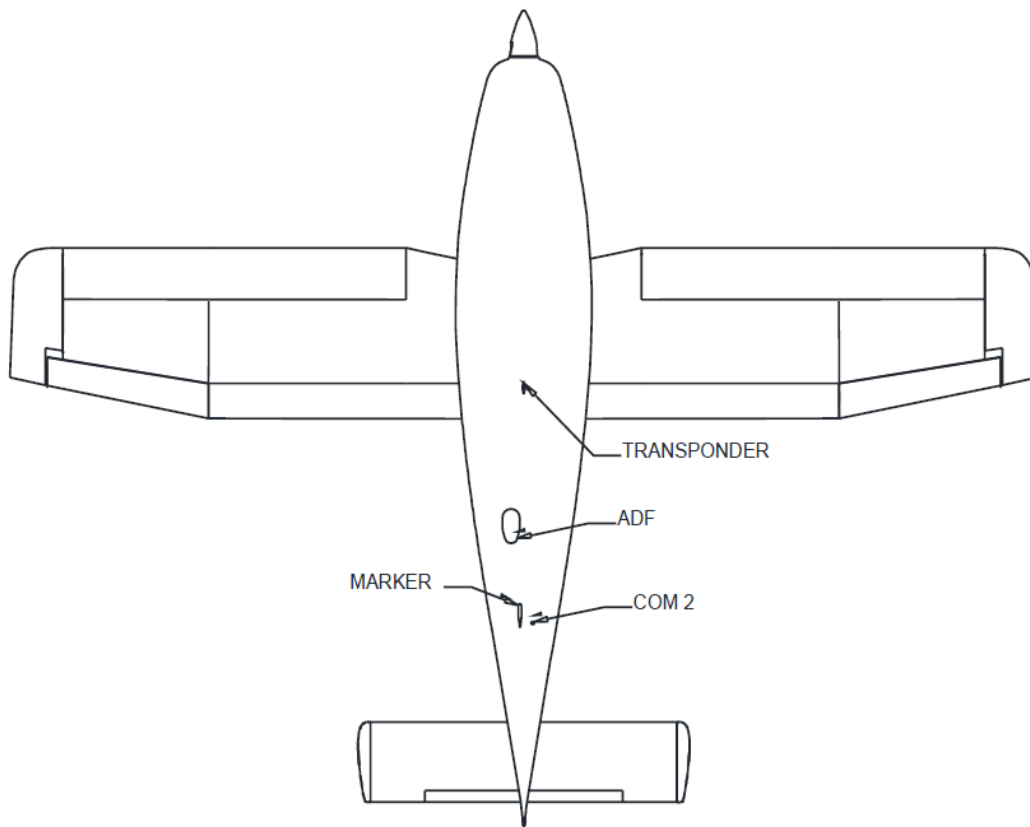

Fig. 3. – Bottom view of antennas positioning on P2008 JC

SECTION 8 GROUND HANDLING & SERVICE

Refer to the basic AFM.

**Supplement no. S12
GARMIN GTR 225A/B / 205**

Record of Revisions

Rev	Revised page	Description of Revision	Tecnam Approval			EASA Approval or Under DOA Privileges
			DO	OoA	HDO	
0	-	First issue	A. Sabino	C. Caruso	M. Oliva	Approved under the authority of DOA, ref. EASA.21J.335 (MOD2008/103.180312)
1	S12-1, 3	MOD2008/125	A. Sabino	D. Ronca	M. Oliva	Approved under the authority of DOA, ref. EASA.21J.335 (MOD2008/125.190711)
2	S12-1, 3	MOD2008/107 MOD2008/239	F. Losappio	D. Ronca	M. Oliva	Approved under the authority of DOA, ref. EASA.21J.335 (MOD2008/237.250715)
3	S12-1 thru 3	MOD2008/238	F. Losappio	D. Ronca	M. Oliva	Approved under the authority of DOA, ref. EASA.21J.335 (MOD2008/238.250729)

List of Effective Pages

Page	Revision
1	<i>Rev 3</i>
2	<i>Rev 3</i>
3	<i>Rev 3</i>
4	<i>Rev 0</i>

INTRODUCTION

The information contained herein supplement or supersede the basic Aircraft Flight Manual embodying the design changes:

- *MOD2008/037 Alternative avionic package based on MD302 and G3X touch (VFR/N);*
- *MOD2008/098 Additional GTR 225A for G3X Touch equipped aeroplanes or MOD2008/125 GTR 225B Installation for G3X Touch equipped aeroplanes or MOD2008/238 GTR 205 Installation.*

GTR 225A/B, or GTR 205, comes optionally installed as a second COM Radio. This supplement furnishes essential information about this installation.

NOTE

For detailed operational instructions related to this equipment, see GARMIN GTR 225/225A/225B Pilot's Guide, P/N 190-01182-00, last issue, or GARMIN GTR 205 Pilot's Guide, P/N 010-02480-01, last issue.

SECTION 1 GENERAL

Refer to the basic AFM.

SECTION 2 LIMITATIONS

Refer to the basic AFM.

SECTION 3 EMERGENCY PROCEDURES

Refer to the basic AFM.

SECTION 4 NORMAL PROCEDURES

Refer to the basic AFM.

SECTION 5 PERFORMANCE

Refer to the basic AFM.

SECTION 6 WEIGHT AND BALANCE

Refer to the basic AFM.

SECTION 7 AIRFRAME AND SYSTEMS DESCRIPTION

NOTE

Make sure you first applied instructions reported on the basic AFM, Section 7 Airframe and Systems Description.

INSTRUMENT PANEL

GTR 225, or GTR 205, is installed in the center of the cockpit under the GNC 255A, or GNC 215, in place of the transponder GTX 335 that has been placed below the GDU 460 LH display as shown in Fig.1.



Fig. 7-1. INSTRUMENT PANEL

ELECTRICAL SYSTEM

GTR 225, or GTR 205, is connected to the audio panel GMA 340 or 345 and to the COM 2 antenna. It is powered from the avionic bus through a 10 A circuit breaker labelled *COM 2*, as shown in Fig.1.

SECTION 8 GROUND HANDLING & SERVICE

Refer to the basic AFM.

SUPPLEMENT NO. S13
CHINA AIRCRAFT FLIGHT MANUAL SUPPLEMENT

Record of Revisions

Rev	Revised page	Description of Revision	Tecnam Approval			EASA Approval or Under DOA Privileges
			DO	OoA	HDO	
0	all	Editorial change	F. Auricchio	C.Caruso	M. Oliva	DOA Approval*
1	S13-6	Oil brakes placard update	G.Valentino	D.Ronca	M.Oliva	Approved under the authority of DOA ref. EASA.21J.335 (MOD2008/143.200730)

(*) This document was originally issued under EASA third Country Approval

List of Effective Pages

Page	Revision
S13-2 thru 5	Rev 0
S13-1, 6	Rev 1

INTRODUCTION

This supplement contains supplemental information for a safe and efficient operation of VFR-DAY/NIGHT capable aircraft delivered in China.

For limitations, procedures, and performance information not contained in this supplement, refer to the EASA Approved Aircraft Flight Manual.

LIMITATIONS PLACARDS

The following limitations placards are placed in plain view on the pilot.

The following placards report the speed limitation:

a) **630 Kg MTOW:**



b) **650 Kg MTOW:**



The operating limitations, according to installed equipment configuration, are reminded in the following placards:



On the right hand side of the instrument panel the following placards are placed reminding the observance for “no smoking”:

NO SMOKING

禁止吸烟

In the baggage compartment the following placards are placed

<p>TIE-DOWN HARNESS MAX WEIGHT 20kg [44 lbs]</p> <p>DO NOT PLACE SHARP OBJECTS ON THE FLOOR</p>	<p>系紧安全带 最大重量20kg (44磅)</p> <p>禁止在地板上放置尖锐物品</p>
---	---

OTHER PLACARDS

Engine compartment placards

<p>OIL TANK CHECK LEVEL</p> <p>OIL LEVEL MAX 3.0 L (0.8 gal) MIN 2.5 L (0.66 gal)</p> <p>OK</p> <p>SAE 10W-40 DETERGENT DO NOT FLY WITH OIL LEVEL OUT OF LIMITS</p>	<p>滑油箱 检查油位</p> <p>滑油油位 最大 3.0 L (0.8 gal) 最小 2.5 L (0.66 gal)</p> <p>OK</p> <p>滑油油位超出限制时， 禁止飞行</p>
<p>冷却液储存罐-0.25L 50%丙二醇</p>	<p>冷却液储存罐-0.25L 100%丙二醇</p>
<p>COOLANT OVERFLOW BOTTLE KEEP LEVEL BETWEEN MINIMUM AND MAXIMUM</p>	<p>冷却液溢流瓶 保持液面在最大值与最小值之间</p>

Usable fuel markings

<p>Left Tank Usable Fuel 60 litres</p>	<p>左油箱 可用燃油 60升</p>
<p>Right Tank Usable Fuel 60 litres</p>	<p>右油箱 可用燃油 60升</p>

Allowed fuel placard

车用汽油
 ASTM D4814 (95号以上)
 EN 228 Super/Super Plus (95号以上)
 航空汽油
 100LL (ASTM D910)
 容量 - 62升 (16.3 US 加仑)

Emergency exit placard

EMERGENCY EXIT
 应急出口

Parking brake placards

PARKING BRAKE
 停机刹车

Choke placards

CHOKE
PUSH
 节流阀
 按压

Master/Generator placards

开
ON
 MASTER GENERATOR
 主开关 发电机
OFF
 关

Safety equipment location placards

FIRST AID KIT
FIRE EXTINGUISHER
are in the luggage
compartment

急救箱
和灭火器
在在行李舱内

Elt placard



Battery placards

BATTERY INSIDE
BEHIND
THIS PANEL

内有电池
在此嵌板后面

External power placards

EXTERNAL POWER RECEPTACLE
外接电源接口

12 Volt - DC

No Step placards



Lift Point placards



Static Source placards



Oil brakes placards (not applicable for aircraft embodying MOD2008/132)



Supplement no. S14

AFMS FOR GARMIN G3X Touch (VFR Day)

Record of Revisions

Rev	Revised page	Description of Revision	Tecnam Approval			EASA Approval or Under DOA Privileges
			DO	OoA	HDO	
0	All	Editorial revision	G. Valentino	D. Ronca	M. Oliva	EASA Approval 10066329
1	S14-1, G7-13	MOD2008/100	A. Sabino	D. Ronca	M. Oliva	Approved under the authority of DOA ref. EASA.21J.335 (MOD2008/100.190614)
2	S14-1, G2-28	Typo on label switch	G.Valentino	D. Ronca	M. Oliva	Approved under the authority of DOA ref. EASA.21J.335 (MOD2008/143.200730)
3	S14 - 1, G7 - 7	Update for MOD2008/148	L.De Salvi	D. Ronca	M. Oliva	Approved under the authority of DOA ref. EASA.21J.335 (MOD2008/162.210701)
4	S14 - 1, G4 - 3	Normal procedures optimization	G.Valentino	D. Ronca	M. Oliva	Approved under the authority of DOA ref. EASA.21J.335 (MOD2008/199.230605)
5	S14 - 1, G2 - 28, G7-13	Typos MOD2008/239	F. Losappio	D. Ronca	M. Oliva	Approved under the authority of DOA ref. EASA.21J.335 (MOD2008/239.250630)

List of Effective Pages

	Page	Revision
Cover Pages	S14-1	Rev 5
	S14-2 thru 8	Rev 0
Section 2	G2-19, G2-20, G2-22	Rev 0
	G2-28	Rev 5
Section 3	G3-6	Rev 0
Section 4	G4-3	Rev 4
Section 7	G7-6, G7-12, G7-15	Rev 0
	G7-7	Rev 3
	G7-13	Rev 5

INDEX

Section 1 – GENERAL	4
Section 2 – LIMITATIONS	5
Section 3 – EMERGENCY PROCEDURES.....	6
Section 4 – NORMAL PROCEDURES	7
Section 7 – AIRFRAME AND SYSTEMS DESCRIPTION	8

INTRODUCTION

The information contained herein supplements or supersedes the basic Aircraft Flight Manual.

It is the owner's responsibility to replace the mentioned pages in accordance with the instructions herein addressed section by section.

Supplement S8: pages replacement instructions

SECTION 1 – GENERAL

**Make sure you first applied instructions reported on the basic AFM,
Section 1 General**

Refer to the basic AFM, Section 1 – General.

Supplement S14: pages replacement instructions

SECTION 2 – LIMITATIONS

**Make sure you first applied instructions reported on Supplement S1,
Section 2 – Limitations**

According A/C configuration apply following pages replacement:

Supplement S8 pages		Basic AFM pages	Supplement S4 pages	Supplement S7 pages	Supplement S9 pages
G2-19	REPLACES	2-19	/	/	/
G2-20	REPLACES	2-20	/	/	/
G2-22	REPLACES	2-22	/	/	/
G2-28	REPLACES	2-28	/	/	/

20. KINDS OF OPERATION EQUIPMENT LIST (KOEL)

This paragraph reports the KOEL table, concerning the equipment list required on board under CS-VLA regulations to allow flight operations in VFR Day.

Flight in VFR Day is permitted only if the prescribed equipment is installed and operational.

Additional equipment, or a different equipment list, for the intended operation may be required by national operational requirements and also depends on the airspace classification and route to be flown. The owner is responsible for fulfilling these requirements.

NOTE

Garmin G3X provides primary flight parameters information, supported by caution/warning lights in the annunciator panel and engine parameters analogue indicators.

AFMS S14 - G3X Touch (VFR Day)

Equipment	VFR Day
MAGNETIC DIRECTION INDICATOR	•
ANALOGUE FUEL QUANTITY INDICATORS	•
ANALOGUE CT (or CHT if applicable) INDICATOR	•
ANALOGUE RPM INDICATOR	•
ANALOGUE OIL TEMPERATURE INDICATOR	•
ANALOGUE VOLTMETER	•
GARMIN 3X TOUCH SUITE	•
TRANSPONDER	•
ALTITUDE ENCODER	•
LONGITUDINAL TRIM INDICATOR	•
FLAP POSITION INDICATOR	•
COMM/NAV EQUIPMENT	•
AUDIO PANEL/MARKER BEACON	•
ANNUNCIATOR PANEL	•
BREAKERS PANEL	•
STALL WARNING SYSTEM	•
FIRST AID KIT	•
HAND-HELD FIRE EXTINGUISHER	•
ELT	•

INTENTIONALLY LEFT BLANK

Upper panel

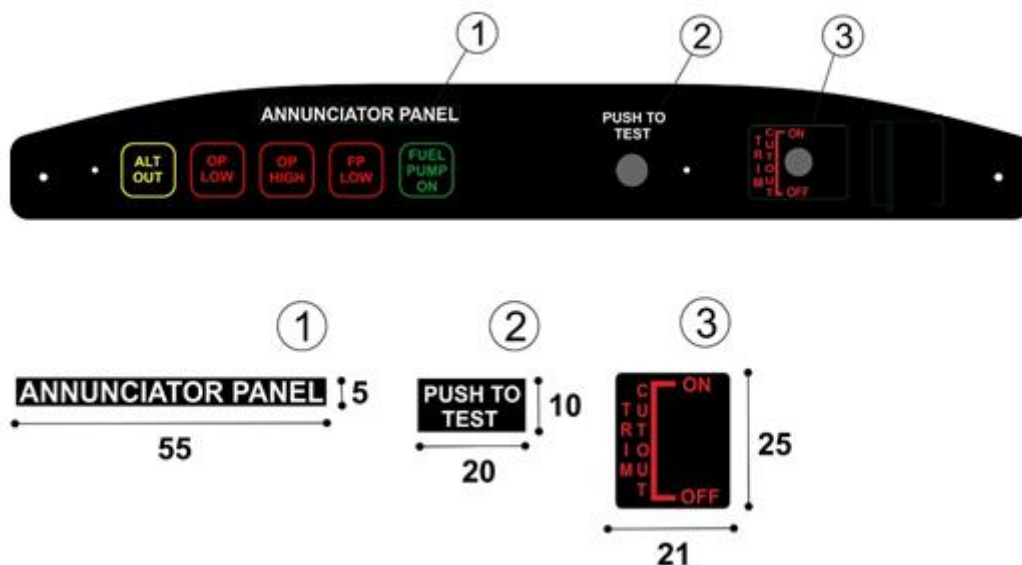

Switches labels

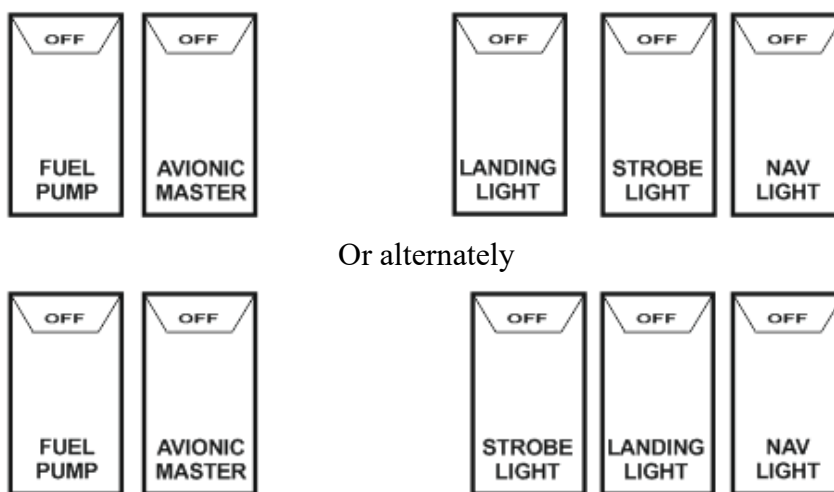

Door lock lever

CLOSED

OPEN

Supplement S14: pages replacement instructions

SECTION 3 – EMERGENCY PROCEDURES

**Make sure you first applied instructions reported on Supplement S1
Section 3 – Emergency Procedures**

According A/C configuration apply following pages replacement:

Supplement S8 pages		Basic AFM pages
G3-6	REPLACES	3-6

2.2. G3X TOUCH FAILURES

2.2.1. LH / RH DISPLAY FAILURE

In case of **LH or RH display failure**, flight data will be automatically available in the remaining display (split mode).



INSTRUCTION: revert to the remaining display.

In case of **LH and RH display failure**, use engine (RPM) parameters and stall warning for airspeed reference and external reference for altitude.

Land as soon as practical.

2.2.2. LOSS OF ENGINE PARAMETERS ON G3X

INSTRUCTION: refer to engine parameters warning lights (OP LOW and FP LOW) and CHT/CT backup indicator.

Supplement S14: pages replacement instructions

SECTION 4 – NORMAL PROCEDURES

**Make sure you first applied instructions reported on the basic AFM,
Section 4 – Normal Procedures**

According A/C configuration apply following pages replacement:

Supplement S8 pages		Basic AFM pages
G4-3	REPLACES	4-3

1. INTRODUCTION

Section 4 describes checklists and recommended procedures for the conduct of normal operations for *P2008 JC* aircraft.

NOTE

Garmin G3X provides primary flight parameters information, supported by caution/warning lights in the annunciator panel and engine parameters analogue indicators.

NOTE

Wearing ear plugs as well as the use of noise canceling systems can somehow decrease the ability to adequately perceive audio alerts.

Supplement S14: pages replacement instructions

SECTION 7 – AIRFRAME AND SYSTEMS DESCRIPTION

**Make sure you first applied instructions reported on the basic AFM,
Section 7 – Airframe And Systems Description**

According A/C configuration apply following pages replacement:

Supplement S14 pages		Basic AFM pages
G7-6	REPLACES	7-6
G7-7	REPLACES	7-7
G7-12	REPLACES	7-12
G7-13	REPLACES	7-13
G7-15	REPLACES	7-15

4. INSTRUMENT PANEL

The instrument panel is divided in five areas.

- The main area holds
 - primary flight information instruments (G3X Touch)
 - ELT switch
 - trim LH/RH pilot's switch selector
 - pitch trim indicator
 - chronometer
 - ignition key
 - master and generator switches
 - engine instruments (Oil Temp., RPM, CT/CHT, Voltmeter)
 - breakers panel
 - two fuel indicators
- The upper area holds
 - stabilator trim cut out switch
 - annunciator panel, with the following indications
 - ALT OUT..... (AMBER)
 - OP LOW..... (RED)
 - OP HIGH..... (RED)
 - FP LOW..... (RED)
 - FUEL PUMP ON..... (GREEN)
- The left section of the lower bezel holds
 - ignition key
 - emergency fuel pump switch
 - avionic Master switch
 - pitot heat switch
 - emergency light switch
 - carburetor heat knob
- The right section of the lower bezel holds
 - NAV, land and strobe lights switches
- The central column holds
 - audio Panel
 - COM/NAV Panel
 - transponder
 - fuel tank selector
 - flap indicator and toggle switch
 - throttle



Fig. 7-5. INSTRUMENT PANEL

* CHRONOMETER SHOWN IS STANDARD EQUIPMENT ONLY FOR A/C NOT EMBODYING MOD 2008/148.

4.1. CARBURETTOR HEAT

Carburettor heat control knob is located lower-LH portion of the instrument panel; when the knob is pulled fully outward from the instrument panel, carburetors receive maximum hot air. During normal operation, the knob is set in OFF position.

4.2. CABIN HEAT

The cabin heat control knob is positioned on the lower right side of the instrument panel; when knob is pulled fully outward, cabin receives maximum hot air. If the outlets are kept closed, hot air only performs windshield defrost. Vents are located by the rudder pedals. If necessary, outside fresh air can be circulated inside cabin by opening the vents on the doors' windows.

9. ELECTRICAL SYSTEM

Primary DC power is provided by an external alternator with a 14 VDC output, rated to 40 Amps @ 5800 rpm. During normal operations, it recharges the batteries. Secondary DC power is provided by a main battery which provides the energy necessary for feeding the essential electrical loads in the event of an alternator failure.

In order to avoid the shut-down of G3X Touch during engine start-up, which is the most demanding phase in terms of current absorption, a 2 Ah valve regulated lead-acid buffer battery is installed.

This secondary battery can also provide additional electrical power in the event of an alternator failure or a total loss of electrical system. This battery is enabled by the master switch and is only connected to the G3X Touch units. It is installed beside the main battery and is housed in a dedicated box.

The switch between the energy sources (alternator and main battery) is automatic and no action is required in order to activate the alternate energy source.

For ground maintenance and/or starting, an external power socket is provided.

The alternator and battery are connected to the battery bus in order to provide energy for the electric equipment.

Each electrically fed instrument is connected to a dedicated circuit breaker which protects the cable from the battery bus to the associated electric equipment.



WARNING

If the Ignition is in the position L, R, or BOTH, an accidental movement of the propeller may start the engine with possible danger for bystanders.

9.1. STALL WARNING SYSTEM

The aircraft is equipped with a stall warning system consisting of a sensor located on the right wing leading edge connected to a warning horn located near the instrument panel.

9.2. AVIONICS

The avionic system installed P2008 JC is based on G3X Touch integrated avionic suite, which provides primary flight information. It is located in the centre of the instrument panel.

On the right side of the instrument panel, analogue indicators provide primary information of engine parameters, (RPM, oil temperature and CT/CHT).

Below engine instruments, a dedicated analogue voltmeter, which provides primary information of the electrical power supplied, and two analogue fuel quantity indicators are installed.

G3X also embodies a GPS WAAS receiver whose information, intended for situational awareness only, are presented on RH display moving map.

Two dedicated indicators provide the pilot with information about the flaps and pitch trim position.

Stand-alone external COM/NAV and transponder sources (Garmin GNC 255A, or Garmin GNC 215, and GTX 335) are installed. Garmin GNC 255A, or Garmin GNC 215, navigation information is presented on the display (course and direction) along with the information related to active/standby frequency. This information is supplemented by an HSI indicator on G3X Touch LH display.

GTX 335 transponder provides SSR (Secondary Surveillance Radar) responses; this unit is capable of both mode "S" and mode "C". An external altitude encoder (ACK A-30) allows altitude reporting, this information is also presented on GTX 335 display. An automatic reversion mode is integrated within the system in order to continue providing the pilot with the flight and engine information in the event of a LH or RH display failure.

Five annunciator lights located on the top centre area of the instrument panel are available:

- Electric fuel pump ON (GREEN)
- Low Oil Pressure (RED)
- High Oil Pressure (RED)
- Low Fuel Pressure (RED)
- Alternator Fail (AMBER)

Optional equipment:

KN63 DME System

The system is composed by the KN63 (DME Receiver), KDI572 (DME Indicator) and CI105-16 (DME Antenna).

KR87 ADF System

The system is composed by the KR87 (ADF Receiver), KI227 (ADF Indicator), KA44B (ADF Antenna).

10. PITOT-STATIC PRESSURE SYSTEMS

The P2008 JC air speed/altitude indicating systems are connected with a Pitot-Static system based on a total pressure/Pitot probe (Heated Pitot tube) mounted under left wing and two static pressure ports connected in parallel and located in correspondence of engine firewall on left and right side of fuselage. Flexible plumbing connects total pressure and static ports to primary instruments. An alternate static source is located in the cabin, operated by a dedicated control.

Garmin ADAHRS (GSU25) unit, installed on the rear side of the fuselage near the battery, acts as an air data computer for Garmin G3X suite, it is connected to both static and total pressure lines providing on that suite both air speed and altitude information.

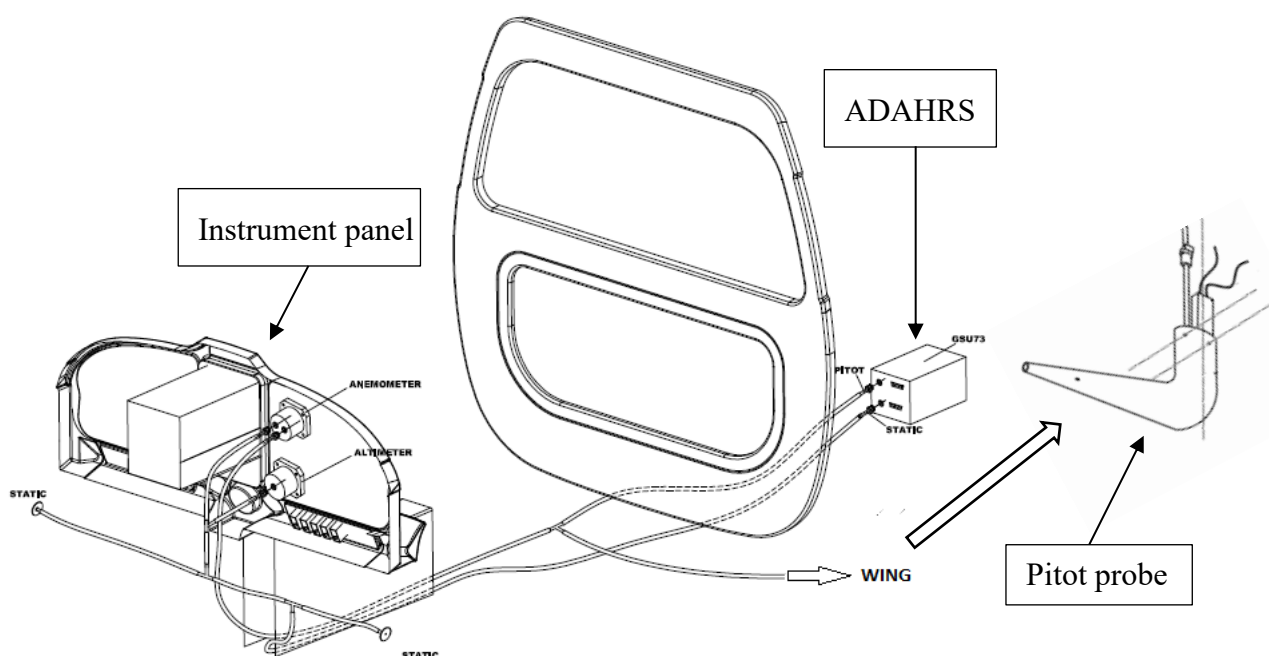

FIG.7-8. PITOT-STATIC SYSTEM